

# Safety Solutions

[www.scat-europe.com](http://www.scat-europe.com)



# Contents

## Introduction ..... 4

Safety Solutions - Make your Lab a safer Place ..... 6

Articles, Reviews and Useful Information

- Everything revolves around Safety ..... 12
- Safe handling of Solvents in the Laboratory ..... 14
- Ensuring Safety - Every Day in the Lab ..... 16
- The Underestimated Cost of Laboratory Air..... 20
- Risks of Electrostatic ignition in the Laboratory  
When handling flammable Liquids ..... 22
- Protect your Health - Key Regulations & Laws ..... 28
- Laboratory Safety with Passion..... 30

## The System ..... 34

HPLC-Supply ..... 36

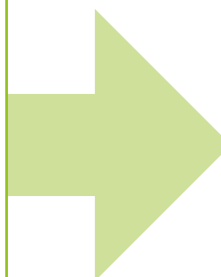
HPLC-Disposal ..... 62

Safety Funnels ..... 100

Level Control ..... 118

Containers ..... 130

Accessory ..... 150



**Detailed overview  
on page 34**

## Addendum ..... 170

**Useful Informations about Material & Technology**

Thread Determination ..... 172

Materials & Chemical Resistance..... 182

Safety Instructions ..... 186

GHS Hazard Symbols ..... 187

Terms & Conditions..... 188



# We bring You Safety and Comfort

Thank you very much for your interest in SCAT!

SCAT stands for **S**afety **C**entre for **A**nalytical **T**echnologies in the area of solvent supply and disposal. Today's innovation and quality leadership of SCAT Europe GmbH is based on SCAT's former maintenance and service operation of HPLC systems in analytical laboratories. During visits to customers, we have repeatedly experienced the risks that are taken in everyday laboratory work. Users often even came into direct contact with solvents. The health of the employees was clearly at stake here!

The driving force behind our mission is to make laboratories safer - on behalf of lab staff and the environment.

Therefore, we proceed in two dimensions. On the one hand, we use our many years of technological know-how to offer users the greatest possible safety when handling solvents. On the other hand, we never tire of explaining and raising awareness of the health risks that exist and how these can be avoided with our products.

SCAT was the first to enter the market in 1998, and since then has been developing products with a lot of passion and a high level of quality awareness that create more safety. We take the next evolutionary steps systematically and continuously, developing new ideas and using new technologies. In doing so, we never lose sight of our claim to be the market leader.

In many of our products, you will find the quality in the details - for example in our active carbon: with an internal surface area of 1,500 m<sup>2</sup>/g, we achieve a CTC adsorption rate of > 90% for solvent vapours. Vapours from acids and alkalis are also bound by two additional layers of activated carbon. This is unique! We never cut costs at the expense of quality, and constantly invest in high-quality materials. In this way, we consciously differentiate ourselves from low-cost suppliers and manufacturers of counterfeits.

From our point of view, the highest possible protection and the health of the employees are absolutely uncompromising. Wrong savings lead to a high safety risk for people and the environment.

We have been setting the technological standards for the safe handling of solvents for over 25 years. We are proud that more than 50,000 HPLC systems worldwide rely on the supply and disposal systems from SCAT.

With our catalogue, we give you an initial overview of our product lines and safety concepts. We also provide individual customer solutions. You can always find the latest products and updates on our website. However, we would like you to contact us directly, so we can advise you individually and personally and find solutions for the safety of your employees together.

In any case, we will not remain stuck or even stop making the laboratory world a little safer.

Yours sincerely,



Peter Rebehn  
Executive Partner  
SCAT Europe GmbH



**The most important Thing  
is the Health of the People  
in the Laboratory.**

Preserving this is an essential part of our mission.

Perfect materials and simple, but absolutely safe handling are the requirements for safety.

[www.scat-europe.com](http://www.scat-europe.com)

S·C·A·T

# Introduction

- ✓ SCAT Europe - A Success Story
- ✓ Safety Solutions Made in Germany
- ✓ Articles, Reviews and Useful Information

# Safety Solutions

## Make your Lab a safer Place



Why do we protect HIM...



... but not HER?

We at SCAT cannot understand why, for example, employees in a paint shop are consistently protected from toxic fumes, while laboratory workers are often exposed to the highly toxic solvent fumes from an HPLC system without any occupational safety at all.

Let's take a look at the processes on the supply and disposal side of an HPLC system:

### The process on the supply side of an HPLC system:

An HPLC system extracts solvents from an open or leaky closed supply container (often a 1 litre laboratory bottle, with GL 45 thread). Solvent vapours escape through leaks in the storage bottle.

This has consequences: on one hand, there is a permanent health hazard for the laboratory staff, and on the other hand, the mixing ratio of the eluents can change, which leads to falsified analysis results. Air, dust and dirt particles can be sucked in through loose capillaries and thus get into the highly sensitive analysis devices, which in turn entails impairment of the analysis and time-consuming troubleshooting and corrective measures.

A hermetically sealing Safety Cap can provide a simple and quick solution. Solvents should only come in contact with the highly inert PTFE of the cap to avoid contamination of the eluent. The capillaries are firmly fixed, using fittings with an integrated ferrule (see also **page 156**). A suction filter should be placed at the end of the capillary in the storage bottle (see **page 169**). This is to avoid

## Safety Solutions

### Make your Lab a safer Place

possible micro-contamination of the eluent. It is important that the inner diameter of the fitting is identical to the outer diameter of the capillary.

The same applies here: the smallest leaks unnecessarily endanger work safety in everyday laboratory work and lead to falsified analysis results. Because measuring the diameter of the capillary is very time-consuming, all our Safety Caps are fully equipped with the possible fittings (1.6 mm = green; 2.3 mm = purple and 3.2 mm = blue, see also **page 156**). This saves you a lot of work and the reordering of individual parts. Unused connections must be sealed with blind plugs. Of course, these are also included in the scope of delivery.

Basically, we at SCAT represent the plug-and-play philosophy: We want to make sure that you get all the necessary connections in the scope of delivery. That's why you always have a few fittings left after using the Safety Cap, but you can always be sure that the right ones are included. Safety First!

The freely rotatable core of the Safety Cap enables replacement or change of the storage container without "twisted tubes".

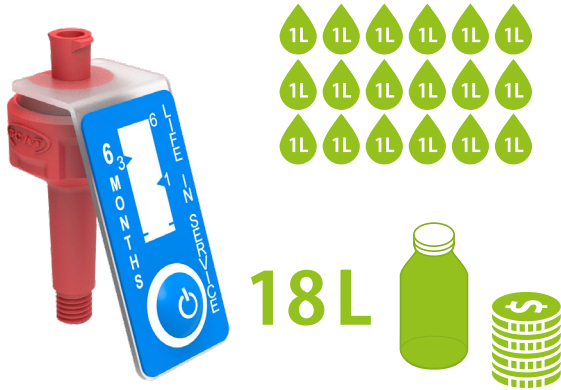
The HPLC extracts the eluent from the supply bottle. If a hermetically sealing Safety Cap is used, the removal creates a negative pressure. If there is no ventilation valve (see **page 53**) on the cap, that cap will not be hermetically sealed - and you will be unnecessarily exposed to a toxic solvent.

To achieve pressure equalization, you always need a ventilation valve. It is important that the ventilation is only conducted towards the inside of the container, otherwise solvents can escape. To ensure that the eluent is not contaminated during pressure equalization, the ventilation valve is also equipped with a PTFE filter that filters the smallest particles from the ambient air. As each filter becomes clogged over time, we recommend changing the vent valves every 6 months. You can either ensure the time measurement on the ventilation valve yourself by making a note, or by activating the supplied time strip, which shows the elapsed time. For the professionals: the Luer Lock adapter on the ventilation valve can be used to gas the eluent or to remove moisture from the air.



### Worldwide trust

Over 80% of HPLC users in Europe trust the developer and market leader of SCAT Safety Caps. In more than 150 countries, our products contribute to more safety at work and in production.



### Air valves

A SCAT Europe air valve prevents the evaporation of up to 750 ml of solvent during its life cycle of 6 months.

With an HPLC system equipped with 4 storage bottles, this makes a volume of 3 litres per half year. In a laboratory equipped with 6 HPLC systems, the ventilation valves prevent the evaporation of approx. 18 litres in 6 months.



## Safety Solutions

### Make your Lab a safer Place



#### Exhaust filter

A SCAT Europe Safety Waste Cap with exhaust air filter, on a 10 litre waste canister, blocks approximately 28 litres of solvent waste, compared to an open canister in the vented laboratory, which can be fed back into the disposal cycle.



In house development: our team of specialists constructs each product according to the latest safety standards.

Safety Caps with a shut-off valve correspond to the highest level of development (see **page 46**). The shut-off valve prevents air intake into the HPLC system to avoid malfunctions or interruptions. Another advantage is that the storage container can be changed almost without dripping.

#### The process at the disposal side of an HPLC system:

After passing the HPLC system, the eluent must be disposed of safely. The structure of a Safety Waste Cap is similar to that of a Safety Cap: both are hermetically sealed, but in contrast to the Safety Cap, the Safety Waste Cap (see **page 68**) does not have a ventilation valve, but rather an exhaust air filter.

Since the rising solvent vapours must somehow escape from the container, an exhaust air filter also has the function of a pressure relief valve. It is extremely important that escaping solvent vapours are reliably bound, strictly speaking, adsorbed by the activated carbon. The performance of the activated carbon is the most important factor for workplace safety in the laboratory. Please take a look at the safety-related explanations on **page 66**.

Important to know: Activated carbon for solvent vapours does not sufficiently bind acidic or alkaline vapours. Since acids or bases are used to adjust the pH of the eluent to neutral, they can also occur in HPLC waste, especially as residues from overdosing. Therefore SCAT uses two additional layers of specially developed activated carbon for acid and caustic vapours. This three-layer model is unique and reflects our motto "Safety First!"

The service life of an active carbon filter depends on many influencing factors, e.g. flow rate, temperature, pressure, design of the activated carbon, solvents used, and many more. The most precise method of measuring the loading of the filter would be a comparative, permanent weight measurement. Since this is impractical in everyday laboratory work, we assumed a worst-case scenario with 24-hour operation of the HPLC and high flow rates for the runtime of our activated carbon.

## Safety Solutions

### Make your Lab a safer Place

We offer Safety Waste Caps in significantly more variants than Safety Caps. This is because there are significantly more disposal containers with different threads and capacities (see also the overview from **page 130**).

If you collect solvents in a container with a capacity of more than 5 litres, the use of electrostatic conductive canisters is recommended according to TRGS 727. The electrical conductivity is achieved by adding an additive, in this case carbon, to the base material PE-HD.

This makes the canister electrostatic conductive, but unfortunately also opaque due to the black color of the carbon. To be able to still keep an eye on the filling level, we offer Safety Waste Caps with level control (see **page 62** onwards).

A closer look at the processes on the supply and disposal side of an HPLC makes it clear that there are a number of weak points where toxic solvents can escape.

We at SCAT are driven to identify these weak points, to sensitize the user and to show ways to eliminate these risks - so that your laboratory remains an all-round safe workplace.



Modern CNC production with our own machinery.



High-quality materials, the latest equipment and precise workmanship: this is our quality standard.



SCAT headquarters near Frankfurt Airport: development, production and logistics in one complex.



## **Safety Solutions**

# **Specialised Articles, Test Reports and Useful Information**

### **Everything revolves around Safety**

**Page 12**

■ Herbert Heidfeldt. Consultant for Environment, Health & Safety, Darmstadt, Germany.

### **Safe handling of Solvents in the Laboratory**

**Page 14**

■ Michael Baldus. Product Manager, NOVIA Chromatographie- und Messverfahren GmbH.

### **Ensuring Safety - Every Day in the Lab**

**Page 16**

■ Test report. SGS Institut Fresenius was commissioned to investigate reduction of emissions achieved by use of SCAT Safety Caps.

### **The Underestimated Cost of Laboratory Air**

**Page 20**

■ Peter Rebehn. Managing Partner of SCAT Europe GmbH.

### **Risks of Electrostatic ignition in the Laboratory When handling flammable Liquids**

**Page 22**

■ Kurt Moritz. Specialist in charge of electrostatics and mechanical explosion protection for the technical plant safety of Merck KGaA, Darmstadt.

### **Protect your Health Key Regulations & Laws**

**Page 28**

■ Important key regulations & laws. SCAT Europe supports enterprises with consultation and can offer standard as well as customized solutions for all areas.

### **Laboratory Safety with Passion**

**Page 30**

■ Article of LABORPRAXIS, Online, October 2022.



# Safety Solutions Product-Catalogue

## HPLC-Supply

- Safety Caps
- Air Valves
- Sets

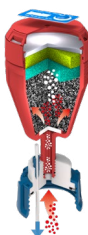


From Page 36

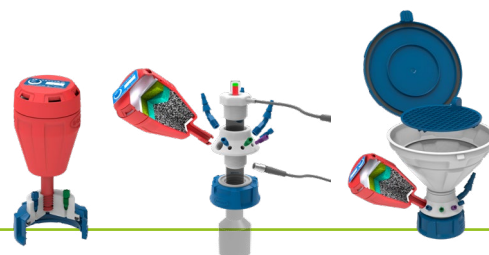


## HPLC-Disposal

- Safety Waste Caps
- Safety Waste Cap LISA
- Universal Waste Hub JAN



From Page 62



## Safety Funnels

- MARCO
- ARNOLD
- Funnels for Barrels



From Page 100

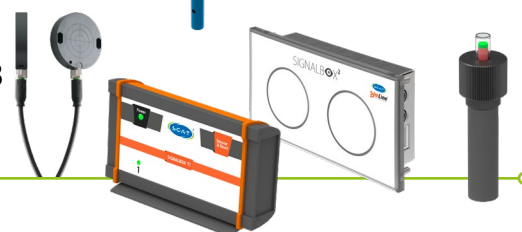


## Level Control

- Sensors
- Signalboxes
- Mechanical



From Page 118



## Containers

- Laboratory Glass Bottles
- Canisters
- Collection Trays



From Page 130

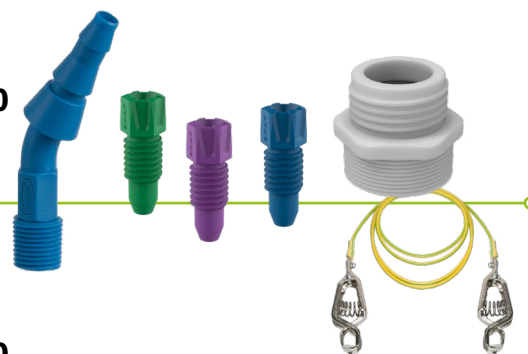


## Accessory

- Air Valves
- Exhaust Filters
- Adapters and more

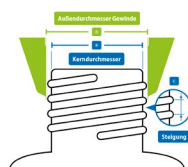


From Page 150



## Addendum

- Thread Determination
- Chemical Resistance Table
- Useful Informations



From Page 170





# Everything revolves around Safety

“In the chemical laboratory, safety isn’t self-evident. SCAT Europe helps its customers to achieve and maintain a very high degree of safety.”



## Herbert Heidfeldt

Consultant for Environment, Health & Safety.

Herbert Heidfeldt began his career over 40 years ago in Research & Development at Merck KGaA. Since 2006, he has worked as a certified auditor, trainer and consultant for Corporate Environment, Health & Safety.

Working in the laboratory means managing complex tasks routinely and reliably. Therefore, this work demands placing a great deal of confidence in the facilities and in their own competence. More and more, supervisors and employees of chemical laboratories have to struggle with the growing occupational safety and legal requirements.

Along with the abundance of requirements, the need for professional help in order to provide competent and practical solutions for the user is also increasing.

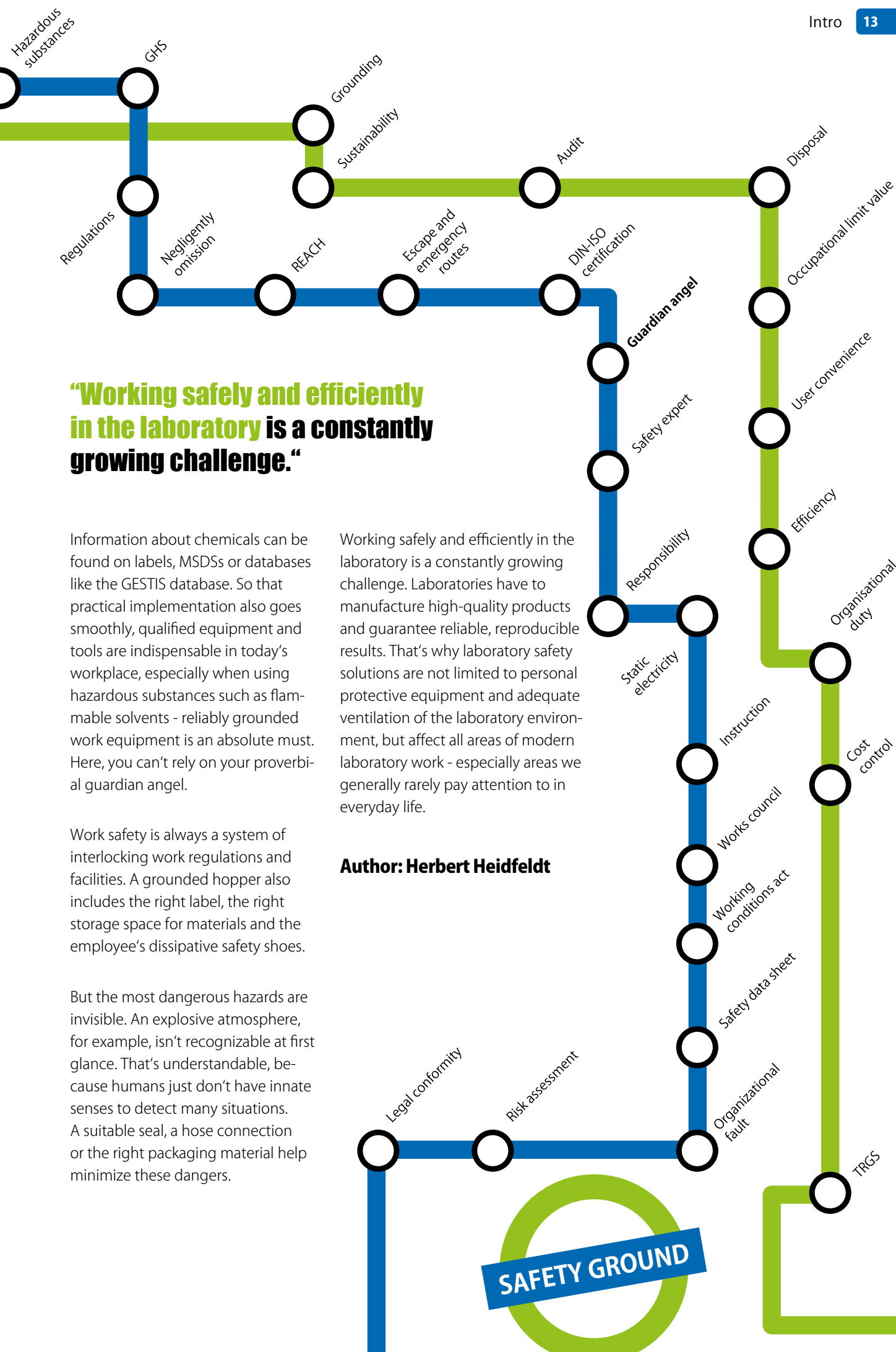
Even as early as planning a laboratory, future risks can be reduced to a minimum by, for example, properly collecting hazardous materials that must be properly disposed of after use. Here, planners, managers and employees often focus on known safety facilities such as emergency exits and routes, signage, emergency showers and eye washes and fire fighting.

However, these are only designed for facilities to limit damages in an emergency. What about preventing these same emergencies from happening in the first place? The entire process chain of using chemicals is replete with dangers, especially their disposal.

Do you know how to handle all your materials properly and safely? Have you planned and tested emergency measures? Do employees receive regular training instruction? Is each next job (or the next upcoming experiment) thoroughly discussed and approved? Have you thought of everything? Or have you just been lucky so far?

### **Only one thing is certain: safety has many faces.**

Especially in our workplaces in chemical laboratories, many sensible solutions help us handle materials properly.



## “Working safely and efficiently in the laboratory is a constantly growing challenge.”

Information about chemicals can be found on labels, MSDSs or databases like the GESTIS database. So that practical implementation also goes smoothly, qualified equipment and tools are indispensable in today's workplace, especially when using hazardous substances such as flammable solvents - reliably grounded work equipment is an absolute must. Here, you can't rely on your proverbial guardian angel.

Work safety is always a system of interlocking work regulations and facilities. A grounded hopper also includes the right label, the right storage space for materials and the employee's dissipative safety shoes.

But the most dangerous hazards are invisible. An explosive atmosphere, for example, isn't recognizable at first glance. That's understandable, because humans just don't have innate senses to detect many situations. A suitable seal, a hose connection or the right packaging material help minimize these dangers.

Working safely and efficiently in the laboratory is a constantly growing challenge. Laboratories have to manufacture high-quality products and guarantee reliable, reproducible results. That's why laboratory safety solutions are not limited to personal protective equipment and adequate ventilation of the laboratory environment, but affect all areas of modern laboratory work - especially areas we generally rarely pay attention to in everyday life.

**Author: Herbert Heidfeldt**

# Safe handling of Solvents in the Laboratory



“Avoiding contamination in the laboratory is absolutely necessary to protect employees against health hazards.”



## Michael Baldus

Product Manager, NOVIA Chromatographie- und Messverfahren GmbH.

NOVIA is a company owned by Provdas Partner für Bildung und Beratung GmbH.

### Does this situation sound familiar?

You're in the laboratory preparing your samples, but you're still thinking about the parallel analysis you just ran and also have to remember to equilibrate your HPLC system. You lose focus for a moment and you've spilled the solvent you wanted to pour straight into the flask.

In my own experience, that's part of a normal workday in the laboratory.

This loss of attention is followed by contamination with hazardous chemicals, particularly solvents. But it isn't just inattention like this; it's also incorrect handling by insufficiently qualified and thus unsuitable laboratory equipment that leads to health and environmental hazards.

Avoiding contamination in the laboratory is absolutely necessary to protect employees against health hazards. The greatest danger for employees is to be unknowingly exposed to risk.

In order to avoid undesired physical contact with hazardous materials, laboratory personnel should observe the basic safety rules for working in the laboratory.

But they can only do so if suitable technical solutions for handling solvents are available and can be implemented.

**In our experience, both the Safety Caps for solvent extraction and the Safety Waste Caps for safe disposal fulfil these requirements ideally.**



## “SCAT Europe systems are demonstrably easy and safe to use“

Responsible activities in the laboratory require well-trained personnel. In doing so, the pure knowledge of occupational health and safety plays a role, especially so-called “awareness”. Only employees who are familiar with the contexts and risks contained in their work and have developed an awareness of security can act appropriately - but only if they know the necessary correct technical solutions and are able to use them.

As a company engaged in the education and training of laboratory staff, we have a high responsibility towards people to inform them about correct practices, necessary expertise and the correct, optimum technical solutions in theory and in practice.

We realize this by making health, safety and environmental protection an integral part of our qualification measures - whether in training, continuing education or programs of study.

All the SCAT Europe systems we implement have proven themselves to be easy and safe to use - whether it's the simple replacement of ventilation valves, the secure closure of the safety funnel with a ball valve or the flexibility provided by the multiple sizes of threaded connections and additional components.

Maximum security is always combined with user-friendliness and easy handling.

### **Conclusion:**

In order to ensure the safe handling of solvents in the laboratory, facilities must include easily usable and reliable tools and systems, as these contribute significantly to occupational health and safety - all systems by SCAT Europe meet these requirements. They also ensure that “clean”, reproducible analysis results are obtained, since the systems avoid contamination of the solvent, even with outside impurities.

**Author: Michael Baldus**

# Ensuring Safety - Every Day in the Lab

“This clearly documents that with the SCAT Safety Cap an evident reduction in the methanol concentration in the test chamber to nearly 0 was achieved, so the workplace limit value of 270 mg/m<sup>3</sup> specified by TRGS 900 was fallen well below.”



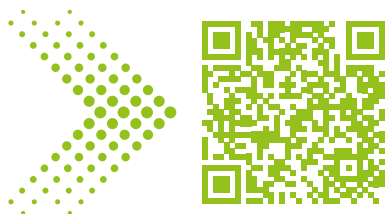
## **SGS Institut Fresenius was commissioned to investigate reduction of emissions achieved by use of SCAT Safety Caps.**

In this respect, 1000 ml solvent bottles with and without Safety Caps were used and the emissions over a period of 28 days compared.

Then test chamber tests were conducted over a period of 7 days, during which the level of emissions in atmosphere were regularly monitored.

The solvent components tested as examples were the tested compounds methanol/water (ratio: 80/20), acetonitrile and methanol.

**Articles and test reports  
also available as download:**



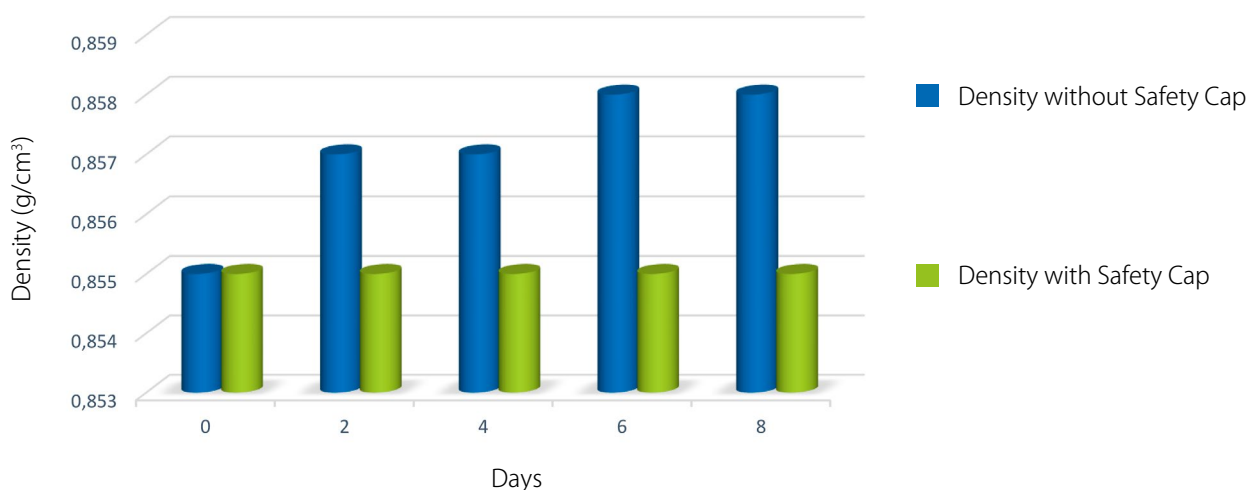
## No change in the mixture ratio was found with SCAT Europe Safety Caps

### Determining the changes in density and volume

SGS Institut Fresenius GmbH was commissioned by SCAT Europe GmbH to evaluate the effectiveness of their SCAT Safety Caps in comparison to a solvent bottle without SCAT Safety Caps. Changes in density of a methanol/water mixture were examined to determine if use of the SCAT Safety Cap could prevent a change in the mixture over an longer time of 8 days.

A comparison of the measured results shows that in a bottle fitted with the SCAT Safety Cap no change in density occurs, the initial density of  $0,855 \text{ g/cm}^3$  stayed constant throughout the entire 8 days of the test. In contrast to this, the solvent bottle without a SCAT Safety Cap displayed a demonstrable change in density so that the initial value of  $0,855 \text{ g/cm}^3$  of the solvent mixture rose to a density of  $0,858 \text{ g/cm}^3$  (Fig.1). An increase in density indicates that there has been a greater loss of methanol than of water from the mixture. This loss did not occur in the same mixture ratio.

Therefore a change in the composition of the methanol/water mixture can be assumed, which then could result in errors in measured values under laboratory conditions. In contrast to this, in the solvent bottle with the SCAT Safety Cap, no change in the mixture ratio was found so that errors in measured values due to a change in the solvent mixture can be excluded.



**Fig. 1** Changes in the density of a methanol/water mixture

Continued on the next page





## Quality Assurance Measures

### SCAT Europe Safety Caps

#### Characterization of the change in volume in methanol and acetonitrile

The first step in this test was to determine change in volume by means of differential weighing over the 28 day pilot study in which both acetonitrile and methanol were specified as solvents. These two solvents were used to generate the best possible comparison with real on-site conditions in a HPLC laboratory. Based on the measurement results it is evident that in both series of trials with the SCAT Safety Cap, scarcely any change in volume over the period of 28 days was observed. In comparison to this, without the SCAT Safety Cap, a significant reduction in the given volume of 1 litre was found within the period of the trial (Fig. 2).

In the acetonitrile bottle without a Safety Cap, a reduction in volume of almost 10% occurred so that after 28 days, only 90% of the initial volume remained in the solvent bottle. Consequently, after 4 weeks, almost 10% of the solvent quantity was lost, having escaped unfiltered into the atmosphere.

During differential weighting to determine the change in volume of methanol, it was evident that an even more significant reduction had occurred in the solvent bottle not fitted with a SCAT Safety Cap: After 28 days, only 87.8% of the initial volume remained in the open solvent bottle, compared with 100% of the initial volume remaining in the solvent bottle equipped with the SCAT Safety Cap. It is obvious that almost 13% of the solvent quantity used are lost, having escaped into the atmosphere from the solvent bottle not fitted with a SCAT Safety Cap.

#### Characterization of the atmospheric concentration by test chamber investigations

In order to investigate the atmospheric emissions caused by open solvent bottles in comparison to a solvent bottle with SCAT Safety Cap, one of each solvent bottles were placed in a test chamber and their respective methanol or acetonitrile emissions were tested after 1, 3 and 7 days (fig. 3).

It was evident that within the test chamber, despite continuous air exchange a methanol concentration of 630–660 mg/m<sup>3</sup> could be determined for the solvent bottle without Safety Cap, whereas a concentration of 1–2 mg/m<sup>3</sup> was analyzed for a solvent bottle with SCAT Safety Cap.

This clearly documents that with the SCAT Safety Cap an evident reduction in the methanol concentration in the test chamber to nearly 0 was achieved, so the workplace limit value of 270 mg/m<sup>3</sup> specified by TRGS 900 was fallen well below.

In contrast to this, without Safety Cap the concentration of 630–660 mg/m<sup>3</sup> clearly exceeds the workplace limit value to constitute a background exposure which can lead to impairment of employees' health in the laboratory.

A similar picture also results from the test chamber investigation with acetonitrile, in which a concentration of 1–5 mg/m<sup>3</sup> was determined with Safety Cap, as opposed to an atmospheric concentration of 730–800 mg/m<sup>3</sup> without the SCAT Safety Cap, despite continuous air exchange (Fig. 3).

Comparison of the detected test chamber emissions with the acetonitrile limit values of 34 mg/m<sup>3</sup> specified by TRGS 900 showed that without the SCAT Safety Cap, the workplace limit value was evidently exceeded. In contrast to this, with the SCAT on the bottle a distinct minimization of the acetonitrile concentration was determined, which was well below the workplace limit value of 34 mg/m<sup>3</sup> specified by TRGS 900 (fig. 4).



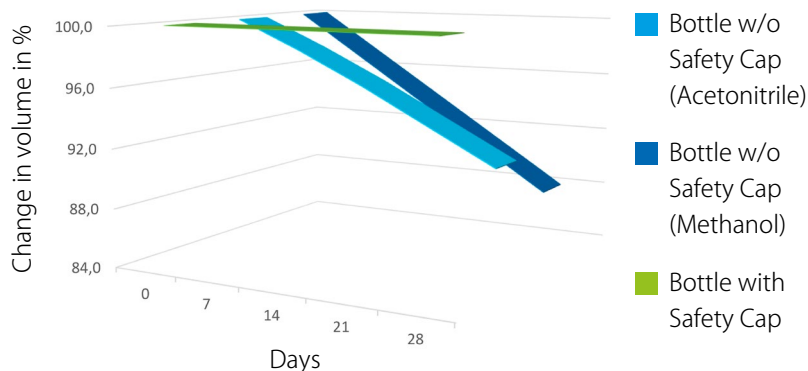
## Test Report Conclusion

### Conclusion

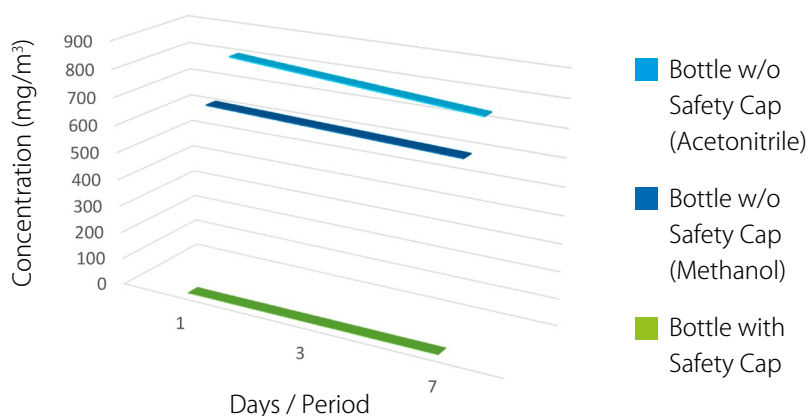
In conclusion, it is evident that solvent emissions could be significantly reduced by the SCAT Safety Caps. In this respect, the use of SCAT Safety Caps can be expected to lead to a clear reduction of the exposure to solvents in the air in a laboratory.

In this connection the reduction in the solvent concentration in the air can be assumed to be of a similar proportion as was described previously, leading to significantly lower health risk for the employees concerned.

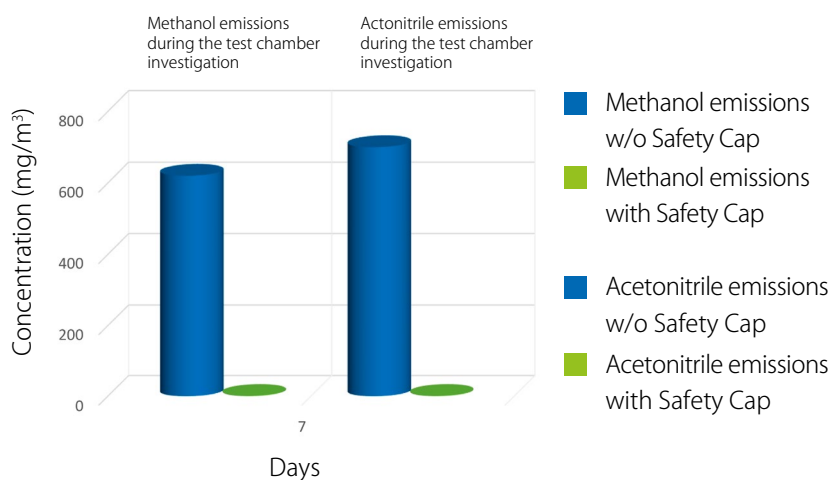
Furthermore, SCAT technology significantly minimizes the risk of contamination of solvent-free blank samples in laboratories, so the use of SCAT Safety Caps can also be considered a measure of quality assurance.



**Fig. 2 Changes in volume of methanol and acetonitrile**



**Fig. 3 Methanol emissions and acetonitrile emissions in the test chamber**



**Fig. 4 Methanol emissions and acetonitrile emissions in the test chamber**

# The Underestimated Cost of Laboratory Air

Source: LABORPRAXIS / October Edition 2020

Air Exchange in the Laboratory // Some ten olympic swimming pools full of air must be pumped through a laboratory of size 120 m<sup>2</sup> - every eight hours. This ensures for the safety of the personnel, but it is expensive and detrimental to the environment. However, if even small measures are undertaken, this can serve to save on the costs involved in air exchange.



## Peter Rebehn

Managing Partner  
of SCAT Europe GmbH.

Everyday work with cancer-causing or toxic materials is unavoidable in many laboratories. There exists a corresponding danger that the workers involved can become sick as a result of respiratory illnesses they might contract. An important protective measure is therefore an efficient exchange of air in the laboratory. The German Federal Institute for Occupational Safety and Medicine (BAUA) demands fundamentally that

for every square metre of floor space, 25 cubic metres of air are exchanged every hour. As a result, laboratories in Germany must be equipped with correspondingly large ventilation systems. Because a human being only breathes in around half a cubic metre of air per hour, a high dilution, and therefore a correspondingly high degree of safety, is thereby provided for, even when toxic materials are being released into it. If it is possible to prove that there is no resulting increase in risk, the BAUA will also allow for a reduced - or even just a natural - level of air ventilation. This brings short-term benefits and saves thousands of Euros.

### **Eightfold exchange standard!**

Conventionally, the rate of air exchange is used as a measure for gauging and evaluating air exchange. It compares the amount of air entering or leaving a room (over an hour) with the volume of air space physically located there. The Air Exchange Rate (AER) is then the resulting given ratio. An AER of 8 therefore means that all the air in a room is fully exchanged some 8 times, during the space of one hour. Exactly how much air per hour and square metre that represents, is dependent

upon the ceiling height of the room. If a room has a ceiling height of 3 metres - as is the case in many laboratories - it results, approximately, in an air exchange of 25 m<sup>3</sup>/m<sup>2</sup>h, as demanded by the BAUA. Therefore, an AER of 8 (more exactly, 8.33) is often used as the general yardstick for laboratories. To clarify further: if the ceiling height is only 2 metres, the total spatial room volume of air would have to be exchanged some 12.5 times per hour, in order to achieve the required 25m<sup>3</sup>/m<sup>2</sup>h.

### **What does laboratory air cost?**

Usually, there is of course a basic wish to keep the amount of air exchanged as low as possible, without correspondingly endangering the health of personnel. This, because the annual costs of exchanging all the air in a laboratory are quite considerable, as the following example involving a laboratory with a floor space of 120 m<sup>2</sup>, that is running around the clock, shows:

- **Air Exchange Rate (AER):**  
25 m<sup>3</sup> / m<sup>2</sup>h
- **Laboratory Area:** 120 m<sup>2</sup>
- **Daily Time for Air Exchange:** 24h
- **Annual Time for Air Exchange:**  
365 d

## The Underestimated Cost of Laboratory Air

If these 4 parameters are multiplied by each other, the result is a total overall air exchange volume of 26,280,000 m<sup>3</sup> / year. If an average air cost of 2 Euros per 1,000 m<sup>3</sup> and year is assumed, it results in a total overall annual cost involved of 52,560 Euros

- an amount which surely offers some good potential for savings!

### Safe reduced air exchange

But what possibilities are there to reduce the AER, yet at the same time fulfilling the technical obligations for hazardous substances, as described in TRGS 526 and as demanded by the BAUA? As mentioned before, the TRGS allows - as described under Para. 6.2.5. - for a reduction of the AER, using various methods, provided the subsequent obligatory assessment of the hazards involved still allows for "the method used to be permanently and sufficiently sustainable and effective." An effective method for reducing the AER is, for instance, to use hermetically sealed caps on laboratory supply bottles. Similarly effective is the use of exhaust filters on canisters at the

waste collection side. By means of such simple methods, it is actually easily possible - in conjunction with an assessment of resulting safety - to reduce the AER from a factor of 8 to one of just 5, corresponding to a reduction of 38%.

15 HPLC units must first undertake a corresponding investment of about 10,000 Euros in the first year (see Table 1). During the following years, there will be further annual costs of some 4,650 Euros, for the required

six-monthly exchange of exhaust filters and air valves. Summing everything up, however, these additional "hardware-related" operating costs will be very much more than compensated for by thereby achieving lower and more cost-effective rates of air exchange. Overall, the annual resultant savings enjoyed every year, as of the second year, are no less than around 15,000 Euros (see Table 2).

**Table 1: Cost calculation for a laboratory with 120 m<sup>2</sup> and 15 HPLC units**


Costs for initial equipping Price/set, comprising: 4x Safety Caps (Extraction) 4x Air valves 1x Waste Cap (Disposal) 1x Exhaust filter 4x Laboratory bottles 1x Waste canister	Running costs half-yearly exchange of (a) Exhaust filter & (b) Air valves
15 x 500 €	(a) 15 x 1 x 75 € (b) 15 x 4 x 20 €
Resultant total cost: 7,500 €	Resultant total cost: 2,325 €
Overall total investment costs in the first year: 9,825 €	

Taking the a.m. annual total overall costs of 52,560 Euros, this corresponds to a savings potential of some 20,000 Euros - for air exchange, there then remain substantially reduced costs of only 32,587 Euros p.a. This cost saving is of course not equivalent to the final direct cost saving involved, as the laboratory must first be equipped with the corresponding hermetically sealed caps. As an example, a laboratory with

This calculation example proves that by implementing such simple measures, every laboratory can save significantly, namely some 15,000 Euros p.a. - and without having to compromise in any way on safety!

**Table 2: Example of amortization with an AER of 5 (basic costs: € 32,587 p.a.), as compared to an AER of 8 (basic costs: € 52,560 p.a.)**

Point in time	Cost of initial equipping	Cost of consumables	Total costs incl. basic costs, with an air exchange rate of 5	Overall summed savings potential since purchase
Year of purchase	7,500 €	2,325 €*	42,712 €	10,148 €
1st Year after purchase	-	4,650 €**	42,712 €	25,471 €
2nd Year after purchase	-	4,650 €**	42,712 €	40,794 €
3rd Year after purchase	-	4,650 €**	42,712 €	56,117 €
		**	= 1x Exchange of exhaust filter & air valve necessary = 2x Exchange of exhaust filter & air valve necessary	



# Risks of Electrostatic ignition in the Laboratory

## When handling flammable Liquids

“Alternatively, the use of conductive or dissipative materials is recommended, as they discharge safely when grounded. In this way the prerequisite for brush discharge, namely charged insulation surfaces, is not given.”

### Author: Kurt Moritz

Kurt Moritz is the expert for electrostatics and mechanical explosion protection in the Technical Plant Safety department of Merck KGaA, Darmstadt.

**Electrostatics**, commonly known as static electricity, is not produced through friction of two surfaces as per popular belief. It is generated by separating surfaces which have previously been in intensive contact. In this context, intensive contact refers to a surface having a dwell time, even if short, and a maximum distance of 10 mm to the other contact surface.

Depending on the conductivity and position in the triboelectric series, materials tend to pick up charged particles on their surfaces or transmit charged particles to the adjacent

surface. In this case, conductive materials serve as electron suppliers (donator), while insulating materials absorb charged particles (acceptor).

If the surfaces are separated quickly after such a charge transfer, and if at least one of these materials is a poor conductor of electricity, the electrical charge can no longer be transferred back to its origin. Consequently, this inability for charged particles to be transferred back results in an excess charge on one surface, while a charge deficiency is created on the other surface. During separation a voltage is generated, reaching up to the magnitude of kV.

Therefore, electrostatics is always a surface effect and occurs on the surface on a molecular or atomic level.

When working with solids, it is easy to recognize separation processes that may lead to chargers, as these are generally visible movements. In general, visible movements are always present. Removing film layers, decanting material from a container or removing a synthetic piece of clothing from the body (fleece, polyester) are all examples that can lead to noticeable and sometimes visible static charge transfers.

As previously explained, for charge separation to occur at least one of the materials involved requires to be a poor conductor. Poor conductors (or “insulators”) include most plastics like PE, PVC, PVDF, PTFE, etc. However, solids are not measured in units of conductivity (unit: S/m) but in terms of their resistance (unit:  $\Omega\text{m}$ ). Siemens/ meter being the reciprocal of ohmmeter, the values are directly comparable, i.e. low conductivity corresponds to high resistance.

## Electrostatics is always a Surface Effect

Liquids are also to be distinguished from an electrostatic point of view. Some substances also demonstrate a high resistance, meaning a poor ability to conduct electric charge.

These include, for example, aliphatic/aromatic hydrocarbons, such as ethers, as well as widely used solvents such as toluene, n-heptane, n-hexane, xylenes, etc.

Some nitriles (such as acetonitrile) and some esters are special in that they lead to unexpectedly high supercharges despite having relatively good conductivity - so far an unknown and hardly investigated effect. This means that electrostatic protection is especially important for such substances.

However, unlike to solids, the process of surface separation of liquids is not always recognizable as such.

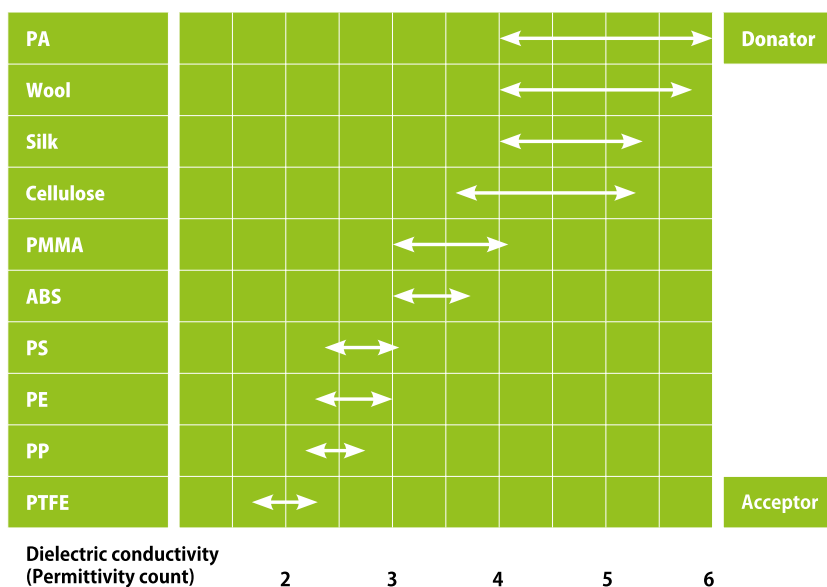
It is difficult to visually distinguish between flowing and stagnant conditions of a liquid-filled glass pipe or semi-transparent HPLC tube.

Even if so: the liquid always remains in contact with the inside surface of the tube/pipe. **However, no surfaces are separated in this process, are they?**

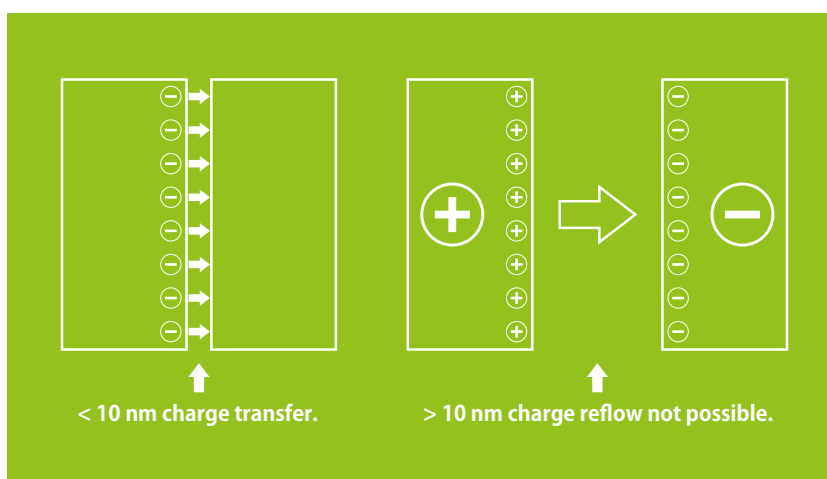
### This is a common misconception.

Unlike solids, a so-called electrochemical double layer (also called a Helmholtz double layer) at the container or pipe wall with different electrically charged layers. While the liquid flows along the pipe, the charge layer primarily located in the liquid is carried along.

Triboelectric range



Materials with higher permittivity serve as electron suppliers (donors).  
Those with lower permittivity tend to accept charged particles (acceptors).



Charge transfer upon contact, charge separation by surface separation.

## Most common Type Discharge by Spark

Surface roughness, flow-inhibiting installations and cross-sectional changes favour these effects, increasing the charge of the system.

Of course, a certain volume of liquid as well as flow velocities are required in order to generate a charge.

In a closed system a flow velocity of typically  $< 1$  m/s is regarded as uncritical, as up to this point an equilibrium of charge transfer and charge reflow exists. However, this limit does not apply to pipe-exit conditions or decanting, since here different volume/surface ratios are given. Furthermore, stopping the liquid flow will not allow for a charge reflow.

For the given reasons, filling a test tube from a laboratory wash bottle does not meet the criteria that lead to critical electrostatic charges, even though the wash bottle is also made of insulating material (generally LDPE or HDPE).

However, charges quantity is transferred at increasing velocities. **This situation may occur in capillaries and tubes of HPLC systems**, particularly when multiple tubes are combined, thus increasing the flow of waste solvents through a single tube. The associated separation or charging processes can be sufficiently strong to result in an electrostatic field being formed around the transfer tubes. If there are components inside the affected charge area which are conductive (such as metal parts) as well as non-grounded, they will become subject to a charge polarisation.

This means that the opposing polarity increases towards the field; the same polarity is repelled. This polarisation effect of charged particles in non-grounded, conductive components can be so strong that a discharge of the excess charge or - depending on polarity - an equalisation of the charge deficit to the next grounded point takes place. Both generally manifest themselves in form of sparks.

A typical example of building up a charge through induction are metallic components such as couplings or brackets connected to a transfer tube made from insulating material.

Even when pouring liquids flowing over surfaces and are, subsequently, collected in containers (e.g. waste solvents that are poured through a funnel into a collection container), charges may accumulate. Initially, the funnel may take on one polarity due to the separation process between liquid and funnel. The oppositely charged liquid collects in the container and transmits its charge to the container. If the funnel and container are not electrically/electrostatically connected to each other, a different electric potential forms on both components, i.e. a charge that can be discharged in the form of sparks. This creates an ignition risk.

Incidents with damaging effects due to electrostatic charges and discharges when transferring liquids and waste solvents are well-known and documented.

### How do you avoid electrostatic ignition risks when handling solvents in laboratories?

There are three different types of electrostatic discharge that apply to laboratory conditions.

A risk assessment taking into account the three types is used to evaluate the risk as well as to specify safeguards, and by this mitigates electrostatic hazards.

**The most common type is the discharge by spark** which always occurs when conductive materials are charged by separating their surfaces from insulating materials or by "induction".

These charged, conductive objects may include

- packaging materials such as canisters, alloy bottles,
- metal containers
- persons
- tools such as funnels, pipe components, sieves and filters
- as well as flammable solvents with high conductivity (alcohols, ketones)

if their charges cannot be discharged.

The charge accumulates in the same way as in a capacitor. If the potential is high enough, the charge is equalized with another conductive object to another potential (generally to the grounded point).

## Avoid Ignition Risks

**The use of conductive or dissipative earthing materials prevents spark discharges.**

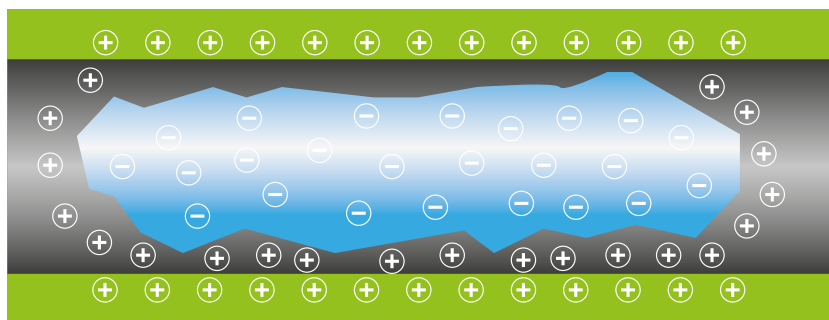
The charge is equalised via the ground connection and a possible charge is harmlessly discharged. At the same time, conductive, grounded containers are capable of grounding the conductive liquids they hold.

**The second relevant type of discharge is the brush discharge.**

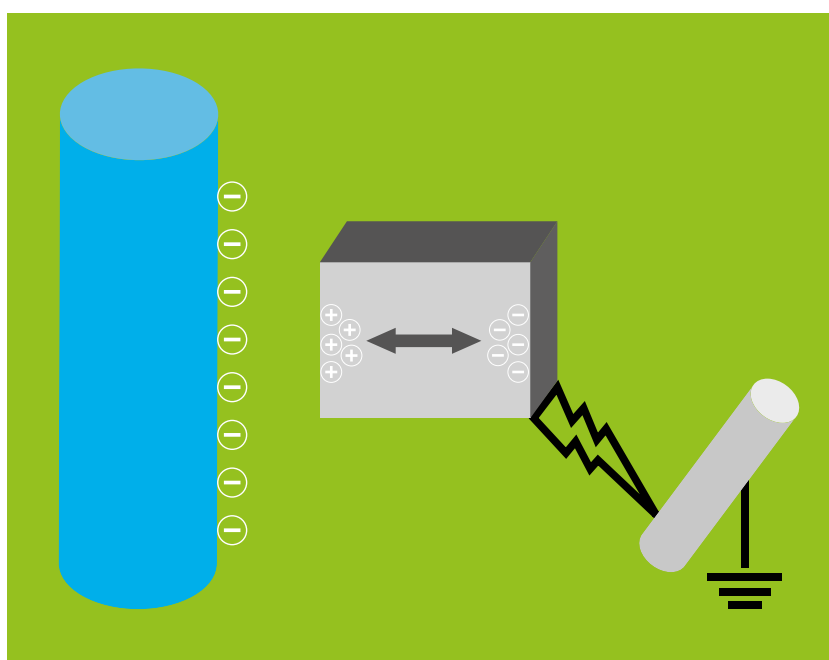
This occurs on surfaces made of insulating material which have been charged by separating operations such as rubbing, wiping, the removal of protective films, etc., or by spraying.

Insulating solid surfaces can only be charged by such surface processes. Charging via induction does not occur in insulating materials, as the poor conductivity does not allow the charged particles in the material to be moved/polarised.

If a charged insulating surface is given a grounded conductor, such as by the approach of a metal object or a person, the electrostatic field concentrates towards this grounding point and develops into a spark manifesting on the surface - the brush discharge.



*Charge separation on a molecular basis during transfer.*

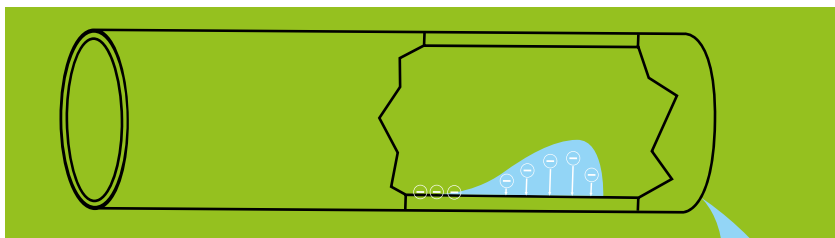


*Polarisation of conductive, non-grounded parts through "induction".*

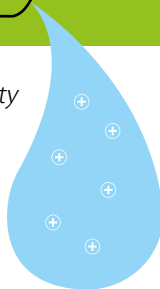
*This may lead to a charge equalisation in form of a spark.*



## Prevent Spark Discharge Use of dissipative Materials



Charge separation when pouring a liquid with high conductivity (such as methanol, THF, acetonitrile) and a body of insulating material (such as PE/PTFE/etc.). Charges can also accumulate with reversed properties (conductive body and insulating liquid).



The safe grounding of conductive components prevents spark discharges. Dissipative materials must also be grounded.

Brush discharges are lower in energy than spark discharges and cannot ignite flammable dust-air mixtures with a minimum ignition energy of  $> 1$  mJ. However, the energy of the brush discharge is sufficient to ignite flammable solvent vapours or combustible gases.

Depending on the combustible material (e.g. belonging to the explosion group IIC) and how likely ignitable solvent vapour-air mixtures are (e.g. "occasional" (zone 1), an insulating material surfaces  $> 20$  cm<sup>2</sup> made of insulating material may be evaluated as critical.

In certain conditions, containers such as canisters, bottles etc or tools made of insulating material are supplied with a manufacturer release for use with flammable solvents. However, the operator must observe the manufacturer specifications and conditions of use (such as "Dry wiping prohibited", "...only for designated use", etc.).

To protect against brush discharges, surfaces made of insulating material must not be charged by rubbing, wiping, or similar operations in the simultaneous presence of flammable vapours.

**Using conductive or dissipative grounding materials avoids insulation surfaces being present. This means that the prerequisite for brush discharges is no longer given.**



## Technical Regulations for hazardous Substances

### TRGS 727

#### **The third type of discharge observed in laboratories is the propagating bush discharge.**

This mainly occurs inside plants and on surfaces made of insulating material if so-called “strong charge-generating processes” take place simultaneously.

For example, these conditions are present in insulating tubes through which aerosols or solid particles are transferred at high velocities.

A tube exposed to the conditions of propagating brush discharge is generally recognisable by a dark mark, with a length of several centimetres. At the centre of the mark perforation of the wall due the discharge can be seen. A propagating brush discharge contains enough energy to ignite fuel-air mixtures of any kind. However, as several conditions are required for the generation of this type of discharge, the probability of occurrence is relatively low. If in doubt, seek an expert opinion.

#### **Since propagating brush discharges only occur on surfaces made of insulating material, the use of conductive or dissipative transport or conveyor systems is also an adequate safeguard in this situation.**

Electrostatics and its ignition risks is a very complex issue. The requirements for components and parts used in so-called hazardous areas, i.e. zones in which flammable atmospheres occur frequently and to a great extent, are effectively regulated.

But even in areas with high air exchange and lower solvent volumes which are not defined as hazardous zones, care must be taken to avoid creating electrostatic ignition sources near emission points or in areas of handling solvents. An electrostatic discharge occurring in this area would inevitably cause the mixture to ignite and, in a worst-case scenario, would cause the container to explode.

Instead, this emission should initially be avoided by using suitable filtration systems. If this is not possible, care must be taken to ensure that no electrostatic hazards can be created near solvent emission points or in areas where these substances are handled (i.e. waste solvent collection points).

In order to do so, it must be ensured that not only the previously specified safeguards for solvent systems are applied, but also additional mitigations such as grounding of operators through dissipating floor mats and appropriate footwear are considered. Electrostatic requirements for the hazardous areas listed above are regulated differently depending on national regulations.

In Germany, the “Technische Regel für Gefahrstoffe” (“Technical Regulations for Hazardous Substances”), or TRGS 727 (formerly TRBS 2153), stipulates electrostatic requirements in hazardous areas under the title “Prevention of ignition hazards due to electrostatic charge”.

At European level, CENELEC (EUROPEAN COMMITTEE FOR ELECTRO-TECHNICAL STANDARDIZATION) CLC/TR 50404:2003 superseded by CLC/TR 60079-32-1:2015 Electrostatics - Code of practice for the avoidance of hazards due to static electricity, is applied.

These regulations describe hazards and specify safety measures. Therefore, this source can also be used as reference or for specific questions.

#### **Author: Kurt Moritz**

Kurt Moritz is the expert for electrostatics and mechanical explosion protection in the Technical Plant Safety department of Merck KGaA, Darmstadt.

# Protect your Health

## Key regulations & Laws

**Hazardous vapours may arise while working with solvents and other hazardous liquids. Inadequate sealing of supply or waste containers creates health risks. Numerous statutory guidelines apply. Always put your own health first.**

In addition to the Chemicals Act, the Hazardous Substances Act is based on the Occupational Health and Safety Act. The employer is responsible for protecting all workers against risks to health through inhalation, skin contact and the physico-chemical effects of hazardous substances.

### In January 2009, regulation (EC) no. 1272/2008 - the CLP Regulation - entered into effect.

It regulates the classification, labelling and packaging of substances and mixtures (Regulation on classification, labelling and packaging of substances and mixtures, or CLP) and replaced the European Dangerous Substances Directive and the Dangerous Preparations Directive in 2015.

The CLP Regulation is based on a UN recommendation to introduce a uniform system for the classification and labelling of chemicals (Globally Harmonised System, UN GHS), which dates back to the 1992 Sustainability Conference in Rio de Janeiro. This represents a compromise between established systems, primarily between North America, the EU and the regulations on hazardous goods.

Source: Bundesanstalt für Arbeitsschutz und Arbeitsmedizin (BAuA). For more information, please visit: [www.unece.org](http://www.unece.org)



### European list of agents that trigger (occupational) diseases (Extract from BKV Annex 1, December 2014. Source: BAuA)

Lead or its compounds • mercury or its compounds • chromium or its compounds • cadmium or its compounds • manganese or its compounds • thallium or its compounds • vanadium or its compounds • arsenic or its compounds • phosphorus or its inorganic compounds • beryllium or its compounds • carbon monoxide • hydrogen sulphide • mucosal lesions, cancer or other neoplasms of the urinary tract by aromatic amines • halocarbons • benzene, its homologues or styrene • nitro or amino compounds of benzene or its homologues • carbon disulfide • methyl alcohol (methanol) • organic phosphorus compounds • fluorine or its compounds • nitric esters • halogenated alkyl, aryl or alkylaryl oxide • halogenated alkyl, aryl or alkyl aryl sulphide • diseases of the teeth by acids • corneal damage to the eye by benzoquinone • para-tertiary butyl phenol • isocyanate • liver disease by dimethylformamide • polyneuropathy or encephalopathy caused by organic solvents or mixtures thereof • diseases of the blood, the blood-forming and the lymphatic system by benzene • cancer of the larynx by sulphuric acid-containing aerosols (...)

## Protect your Health

### Key Regulations & Laws

#### TTRGS 526 “Laboratories” (Technical regulations for hazardous substances)

##### 2 / General information:

Laboratories must (...) be designed and operated according to prior art standards.

##### 3.1 / Risk assessment - Procedure:

Measures to protect against hazardous substances shall be set so that (...) the employees are not exposed to any hazards or loads. If this is not possible, the activity should be designed so that the overall risk to workers is minimized after reviewing alternate measures.

##### 3.3.1 / Exposure assessment:

The employer can generally assume that no unacceptably high exposure to hazardous substances is present if expert (...) personnel is acting in accordance with relevant regulations and prior art (...).

##### 3.7 / Employment restrictions:

Employment restrictions for minors, women of childbearing age, and pregnant and lactating women must be observed (Young Persons Employment Act, Maternity Protection Act and the regulation for the protection of mothers in the workplace).

##### 4.3.1 / Avoiding hazards:

The employer shall design the workplace to avoid hazards or reduce them to a minimum. The duration and extent of exposure to hazardous substances must be limited, (...).

##### 4.11.1 / Release of gases and vapours:

Outside of fume hoods, activities in which gases and vapours may form in hazardous concentrations or quantities may only be performed if suitable safeguards (...) ensure that a threat (...) is excluded.

##### 4.16.1 / Handling waste:

When preparing and filling storage tanks (of waste), no hazardous gases or vapours (...) may leak or otherwise enter into the laboratory air.

##### 5.2.23 / Chromatography (HPLC):

If the system cannot be operated with a fume hood, the released solvent vapours must be vented/dissipated safely.

##### 6.1 / Technical protective measures:

Hazards in laboratories are primarily avoided by ensuring that workplaces are appropriately designed and equipped. These include (...) the nature of the equipment, instruments and (...).

#### TRBS 2153 - Avoiding ignition hazards due to electrostatic charges (Technical regulations for operating safety) (See also TRGS 727)

##### 4.5 Electrostatic charges when handling liquids - small containers

(...) Dangerous charges can be generated by friction, fluid flow or ungrounded persons. In these cases, hazardous discharges to insulated metal components, such as handles, locks, barrel pumps or solid/liquid surfaces, should be expected.

##### 4.5.1 Conductive or dissipative containers

While filling and emptying the container, all conductive or dissipative parts of the system must be electrically connected and grounded.

##### 4.5.5 (3) Isolating containers

In zone 1, the maximum permissible flow velocity is 1 m/s. The maximum permissible volume is 5 l.



# Laboratory Safety with Passion

Source: LABORPRAXIS / ONLINE / October 2022

If a cartoon character sniffs a solvent bottle too much, he becomes a mad professor. In real life, solvent fumes have less entertaining consequences and are therefore to be avoided at all costs. The SCAT company has made this its mission - and thus made laboratory safety its main task.



Fig.1: Laboratory safety can also be done with humor: Jan Rittgasser, director of marketing at SCAT, impersonates the "mad professor" at an exhibition - the company's trademark. An early model of the Safety Caps can be seen in the foreground.

## Laboratory Safety with Passion

In the beginning there was caution, maybe even a bit of fear when you stand in the laboratory for the first time during your training or studies and are confronted with various toxic solvents and carcinogenic chromates. Every move is carefully considered, every test setup is checked twice and three times. Then, over the years, comes practice. The processes become familiar, the safety precautions become known and the handling of hazardous substances becomes routine and safe. From here, it is important to maintain awareness of the potential dangers in the laboratory. Because otherwise, there is a risk of stepping into the next trap: carefree habit. Even the best lab workers, after years of routine, become lax about personal protective equipment or other safety precautions in the lab.

This dilemma is also known to the team at SCAT, the "Safety Center for Analytical Technologies". The company has set itself the goal of supporting users in the analytical laboratory in protecting themselves from harmful substances in the working environment. For almost 25 years, the experts have been developing new technical devices that are intended to make the handling of solvents in wet-chemical laboratories and in HPLC applications safer. The team is there with creative ideas and full commitment and passion. One employee quickly tested his idea of sealing a filling funnel with a rubber lip for practicality: fill the Tupperware container with vinegar water, add a rubber seal and then put it under the bed overnight to do the smell test. This commitment has not only led to SCAT using just such rubber seals on the funnels since then, but also made the committed employee in the company virtually immortal.

**Since then, the funnels have been named after him: MARCO. Other team members have also immortalized themselves in product names, for example in the ARNOLD funnel or in the Universal Waste Hub JAN.**

"All of us at SCAT are driven by the idea of making the laboratory a safe place to work," says Managing Partner Peter Rebehn, summing up the corporate philosophy. In an interview with LABORPRAXIS, he admits that the only exception was the name of the LISA Safety Waste Caps. "It's an artificial name. We already had so many men's names, so it was just about time to include a product with a woman's name."

### The company SCAT

The "Safety Center for Analytical Technologies" SCAT was founded in 1998 to protect users in analytical laboratories from harmful substances in the working environment. The reason was the initial requirement of a large German chemical company to reduce the concentration of pollutants that was too high in a laboratory in which organic solvents were used. SCAT developed its Safety Caps for solvent bottles so that no major conversion work was necessary - the starting point for the success of the almost 25-year-old company. Since June 2020, the developers at the new location of the SCAT headquarters near Frankfurt Airport have been providing improved and new safety solutions for handling solvents in the laboratory.

### The mission: safety – and saving money as a side effect

Peter Rebehn has been Managing Partner at SCAT since 2018, and knows the challenges of everyday laboratory work. "We prefer to visit our customers on site and advise them directly in the laboratory. Since it is our daily bread, we immediately recognize where there are still gaps in occupational safety," he says. A typical picture, which is still far too common in the university context, are HPLC systems whose solvent supply is provided by more or less creative self-sealed storage bottles: sometimes the bottle opening is covered with aluminum foil, sometimes with glass wool, often the hose also stuck through parafilm and sometimes even simply placed in the open neck of the bottle without any further covering.

Even a simple cap is not enough. All of this is more or less insufficient, since the solvent can be so easily dispersed in the air and there is a risk that employees will inhale the noxious fumes. After all, despite increasing efforts to replace toxic substances in the laboratory with less dangerous ones, hazardous substances such as methanol and acetonitrile are still frequently used eluents in HPLC.

In its "Safety Solutions" division, SCAT has therefore specialized, among other things, in safe, hermetically sealing caps for solvent containers, both on the supply and disposal side, for storage bottles as well as for waste containers - and thus apparently hit the right nerve. "I've never met anyone in the lab who said: No, I don't need that," says Peter Rebehn. The Safety Caps are equipped with a ventilation valve, which allows emission-free pressure



## Laboratory Safety with Passion

equalization in the solvent bottle. In addition, an exhaust air filter is screwed on, which adsorbs the solvent vapours and binds vapours from alkalis and acids. The inner surface of the activated carbon achieves a top value of 1,500 m<sup>2</sup>/g, as the expert points out. In this way, workplace limit values for toxic solvents such as methanol or acetonitrile are easily complied with, and the occupational safety of employees is guaranteed.



Fig. 2: The Safety Waste Caps contain three different types of activated carbon for additional safety: 1st layer adsorbs solvent vapours, 2nd layer binds alkalis, 3rd layer binds acids.

Hermetically sealed Safety Caps have another advantage in addition to the safety aspect, emphasizes Rebehn: "Hermetically sealed caps have fewer emissions and therefore less consumption. This is currently becoming more important again, because the prices for solvents are also rising." In addition, thanks to the better sealed

**"Laboratory safety is not limited to products, it also involves a lot of persuasion and educational work."**

Peter Rebehn, Managing Partner of SCAT

solvent containers, the air exchange rate in the laboratory can be reduced from 8 to 5 times without compromising safety, which in turn saves costs in the laboratory, how Security expert Rebehn added. According to a sample calculation for an HPLC laboratory with 15 systems on 120 m<sup>2</sup>, 10,000 to 15,000 euros can be saved every year (you can read more about this in the article "The underestimated value of laboratory air").

### SCAT-Connect-Box for automation in large HPLC laboratories

The latest development by the SCAT team is intended to further improve safety in the HPLC laboratory and also increase user-friendliness. In the spirit of increasing digitization and automation, the product developers have launched a system that can be used to control and monitor the filling level of the storage bottles and waste containers: SCAT-Connect. The heart of this is the SCAT Connect Box. Silicone tubes lead from the central control unit to the individual storage containers. Oxygen is pumped through the tubes and escapes at the tubing's end. The required amount of pressure changes depending on the filling level of the vessel. This relationship allows the fill level to be calculated after a one-off calibration for the solvent used and the associated vessel. "This hydrostatic measuring principle is not new, but it has never been used in our industry in a laboratory context," says Peter Rebehn.

The filling levels determined in this way can then be conveniently viewed in real time via an app on a computer, tablet or smartphone. Another advantage: The system



Fig. 3: With the app for SCAT-Connect, users in the laboratory always have an eye on the fill levels of their solvents.

## Laboratory Safety with Passion

automatically refills the storage bottles from a larger storage tank via pumps, so that it is not necessary to top up with solvent as often. The managing director promises that supply and disposal systems can be fully digitized in the future. This not only saves work, but also reduces the risk of exposure because there is less direct interaction with the solvents. Especially for large analytical laboratories with many HPLC systems, more freedom is created for the laboratory technicians, because sample runs are automated over a longer period of time and work without intervention by the staff. When the waste container is full, the employee receives a message via app to empty or change the container. An audible alarm can also be turned on to indicate critical levels. "We are investing a lot of money here in the future," says Peter Rebehn and is confident that this investment is worthwhile - not only for his own company, but also for the large HPLC laboratories that should benefit from the new technology. Two pilot systems with the SCAT Connect Box are already in use, and more will follow.

### A "Mad Professor" becomes the brand image

The Safety Caps and the SCAT Connect Box are just two examples of how SCAT wants to make work in the laboratory more efficient and above all safer. However, the more than 1,600 items developed in-house for the safe handling of hazardous liquids are not the only part of improving laboratory safety. "It also requires a lot of persuasion and educational work," emphasizes Rebehn.

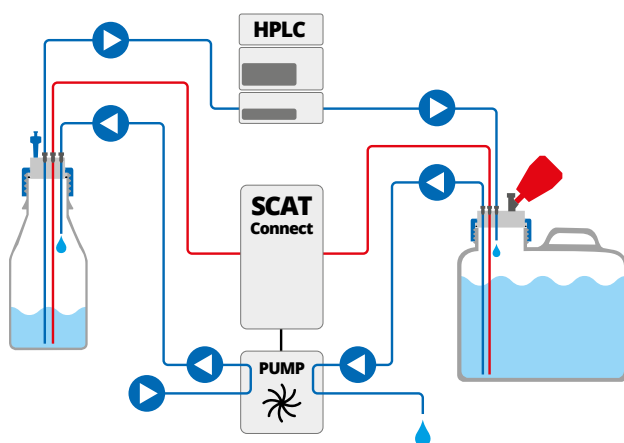


Fig.4: Functional diagram for SCAT-Connect: The system continuously measures the fill levels of solvent and waste containers with millimetre precision using a hydrostatic measurement method. External devices such as pumps can be controlled.

"We are often at trade fairs to sensitize users to the topic and to train them with lectures." This is the only way to counteract the downside of too much routine and avoid careless handling in the laboratory in the long term.

Finally, the comic-like "Mad Professor" of SCAT's branding shows what happens when you don't take laboratory safety seriously. "It was originally intended as a deterrent example," reveals the application specialist. "Because if you inhale too much solvent, it will eventually soften your head."

However, it does not seem to have a real deterrent effect, but rather attracts interested and curious looks, e.g. at trade fairs. The face of the maniacally laughing character now adorns SCAT bags, presentation slides and product packaging and has ensured a high recognition value for the brand. And those who regularly sensitize themselves to the dangers in the laboratory and take appropriate precautionary measures do not have to fear becoming a "Mad Professor" themselves, due to too much inhaled solvent vapour.







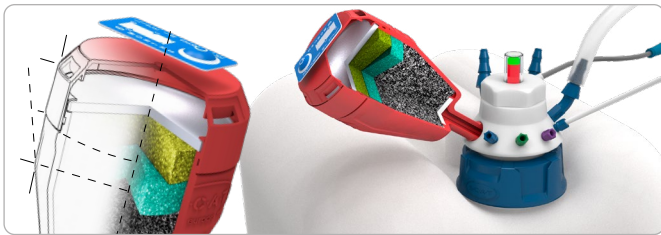
# The System



## HPLC-Supply

Safe Extration of Solvents:  
Safety Caps for Health, Environment & Quality.

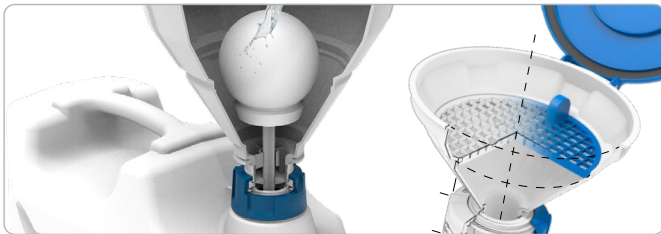
HPLC-Supply



## HPLC-Disposal

Safe Collection of Solvents:  
Strong protection with Safety Waste Caps.

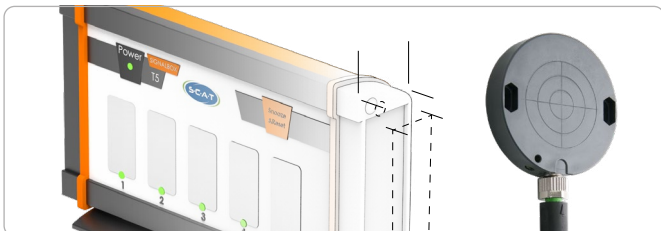
HPLC-Disposal



## Safety Funnels

Fill in Chemicals safely:  
Robust Assistants with clever Technology.

Safety Funnels



## Level Control

Safe Monitoring of Fill and Empty Levels:  
Protection against overflowing Containers.

Level Control



## Container

Safe Containers for every occasion:  
Compatible with the SCAT System.

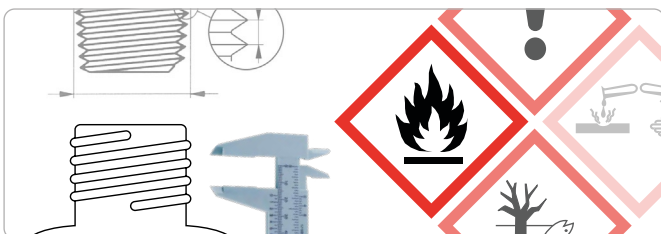
Containers



## Accessory

Spare Parts & useful Accessories:  
Adapt the System to your requirements!

Accessory



## Addendum

Useful Informations about Material &  
Technology: The useful Reference Book.

Addendum

**PROTECTION  
PAYS OFF!**

**WHAT'S ALL THE  
FUSS ABOUT?**

**It has never been so Easy to  
Protect your Health and Save  
Costs at the same Time.**

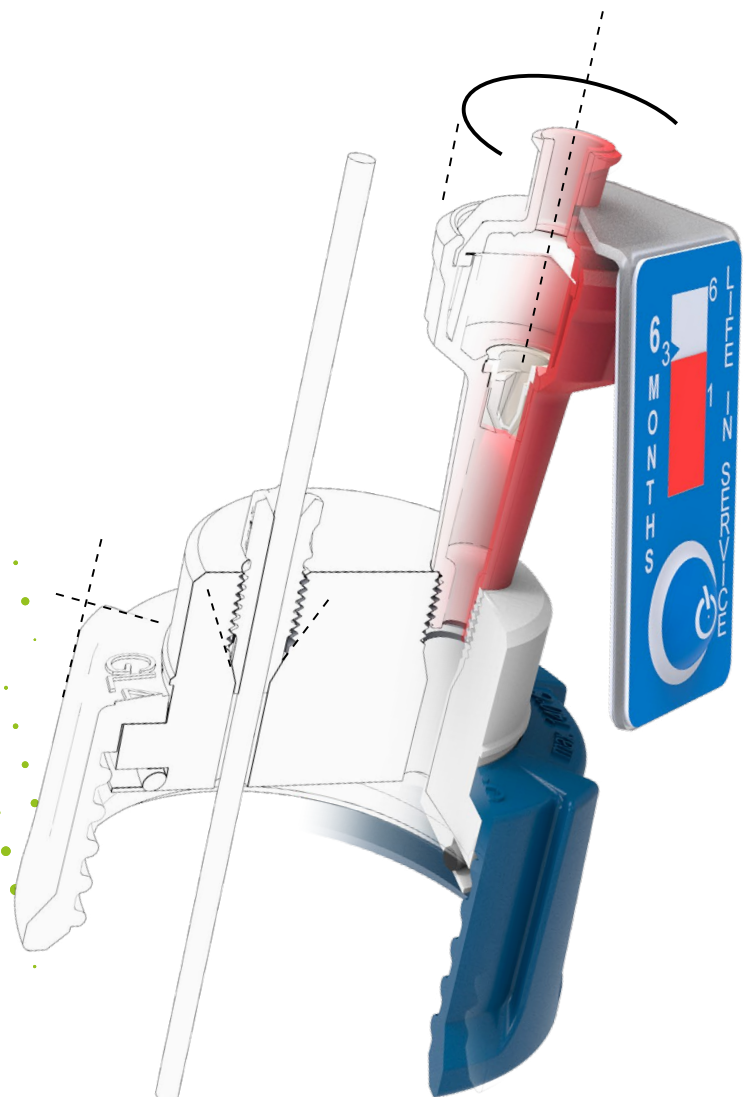
[www.scat-europe.com](http://www.scat-europe.com)

Solvent vapours are not only the cause of many occupational illnesses and breakdowns: especially in instrumental analysis, malfunctions can be costly if they result in interruptions and maintenance work.

Safety Caps protect against hazards from solvent vapours and ensure clean, reliable analysis.

# HPLC-Supply

- ✓ Safe Extraction of Solvents
- ✓ Reliable Health Protection
- ✓ Trouble-Free Analytic
- ✓ Stable Eluents



# Do you Extract your Solvents Safely?

The consequences of **unsafe** extraction.

## Eluent emissions

Non-hermetically sealed containers are a considerable safety risk as eluents / solvents can escape into the laboratory air.

## Unstable mixtures

Solvents are volatile and evaporate already at room temperature. Solvent mixtures thus become unstable and change their mixing ratio - which in turn falsifies the result. Solvent filtration, accurately prepared eluents and a constant mixing ratio over the entire application time are a must, especially with UHPLC.

## Contamination of the eluent

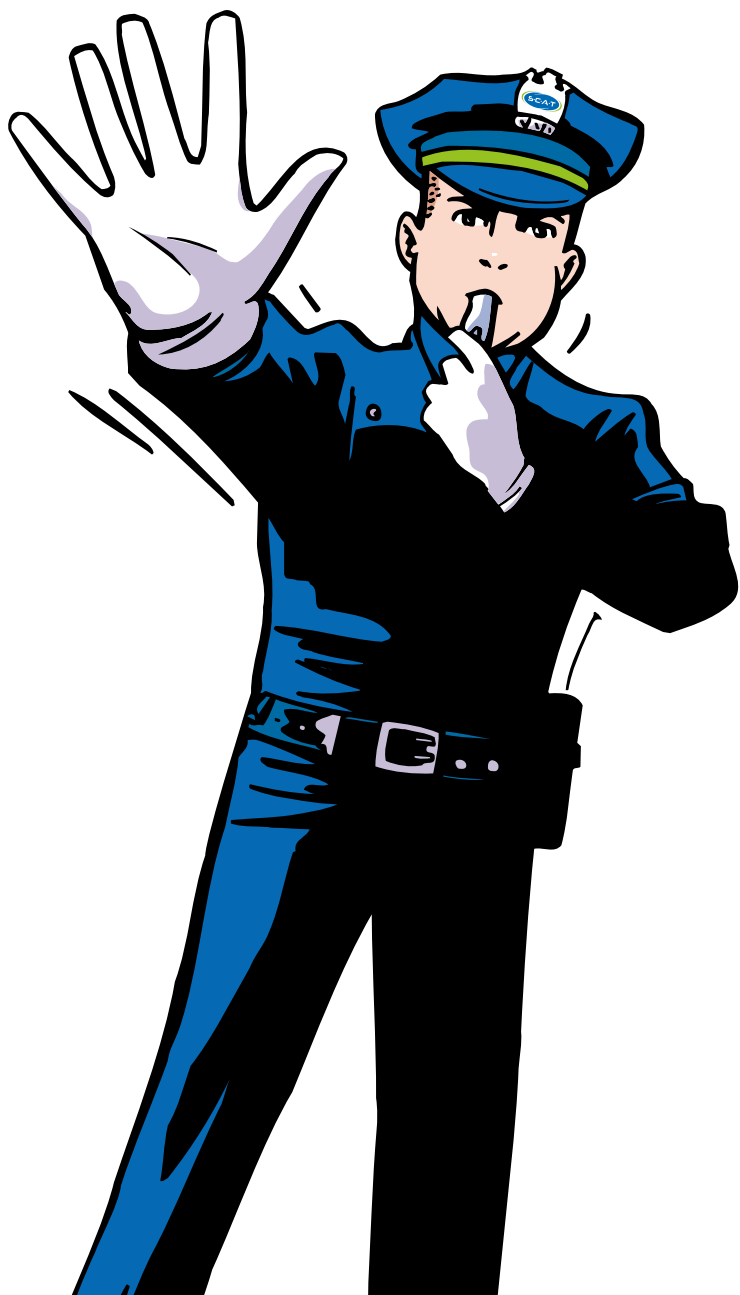
Dust, dirt and impurities from the ambient air can contaminate the mobile phase - and have a disturbing effect on the chromatogram. A lot is invested in developing the method for a clean separation. Contamination can create overlapping peaks, and make it difficult to detect the substance you are looking for.

## Air in the HPLC

The results of your analyses are also affected by the handling of solvents. Tubes can slip out of the storage bottle if they are not screwed tightly. The consequence: aspirated air gets into the HPLC system and downtimes are pre-programmed.

## Handling chaos

With ordinary screw caps, handling when changing solvents is often awkward. Twisted capillaries create the famous "hose tangle" when the storage bottles have to be changed.



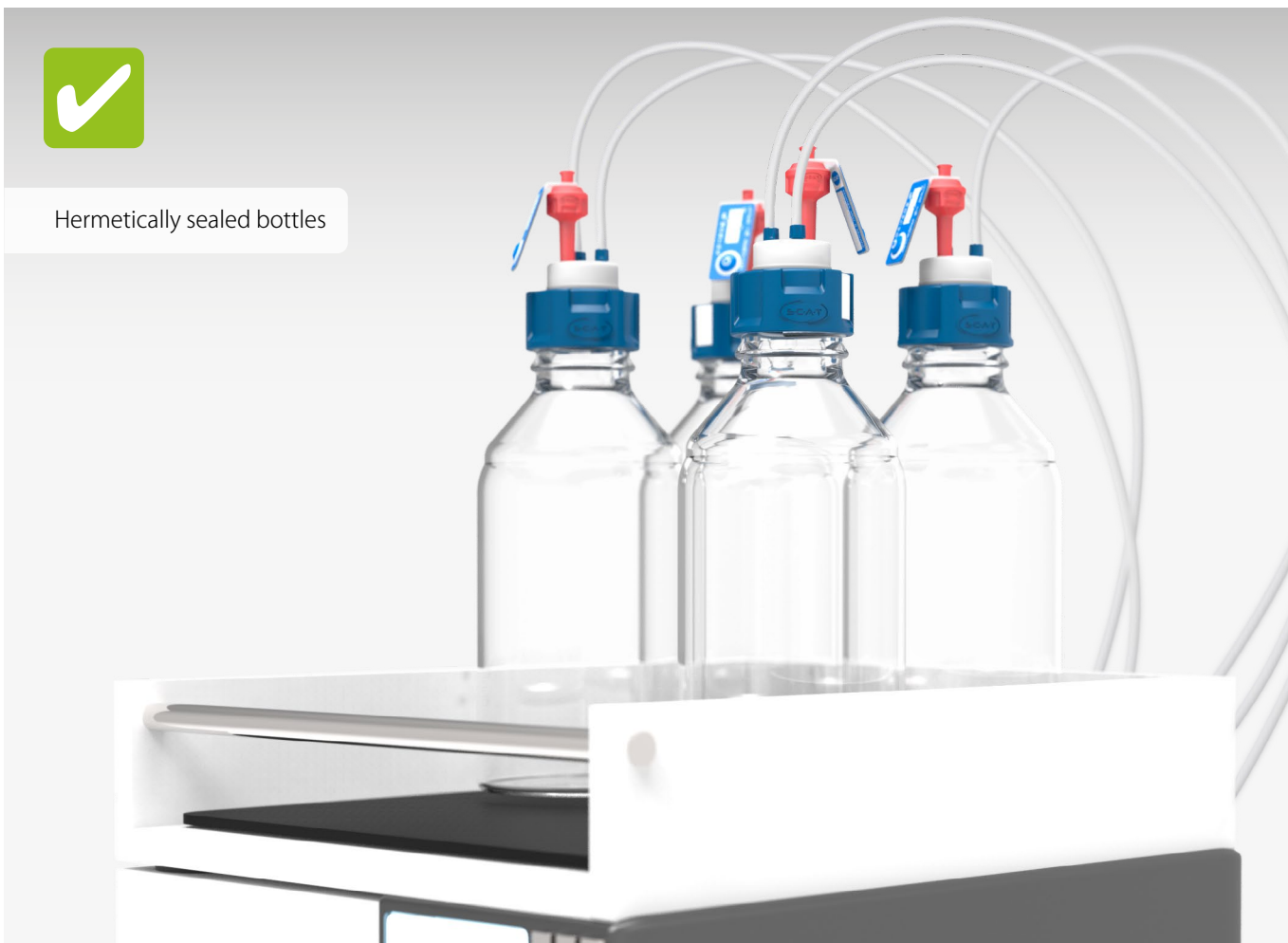
## You know This? Comparison



Open, unsealed bottles



Hermetically sealed bottles





# Safety Caps

## The Safety Standard for HPLC



## Safety Caps

### The Benefits at a Glance

#### ✓ Best possible Protection against Vapours

The hermetically sealing SCAT Safety Caps ensure that no solvent vapours escape.

#### ✓ Safe Pressure Equalisation

When extracting the eluent, a negative pressure is created in the container. The SCAT air valve ensures safe pressure equalisation during HPLC operation.

#### ✓ Clean Mobile Phase

The valve membrane of the air valve retains dust and dirt particles from the ambient air. Analysis results remain unaltered and reproducible. For clean separation without interfering or overlapping peaks in the chromatogram.

#### ✓ Stable Mixtures

Due to the closed system, your solvent mixtures remain stable. Individual components can no longer evaporate - the mixing ratio remains constant.

#### ✓ Analysis without Air Bubbles

Capillaries and tubes remain tightly screwed in and cannot slip out of the solvent. Interruptions due to air pockets are avoided.

#### ✓ Easy Container Change

The freely rotating cap can be easily removed even with the tubes fitted - without twisting or "tube tangle". Your storage containers are changed quickly and conveniently.

#### ✓ Safety for every HPLC Type

Whether HPLC, UHPLC or preparative HPLC: Safety Caps are optimised for all typical solvents and flow rates in chromatography. Each solution is extensively tested in practice before it finds its way into our range.

#### ✓ Best Chemical Resistance

Anyone who works with organic solvents knows how important it is to use chemically resistant materials. Therefore, we only use officially tested high-performance plastics with clearly defined and verifiable properties for the production.

#### ✓ Safely through the Audit

HPLC instruments with SCAT equipment pass any quality or safety test according to the latest safety standards. That is why the SCAT system is part of the basic equipment for laboratory safety at leading pharmaceutical and chemical companies worldwide.

#### ✓ Compatible across Generations

The valve and all other components are compatible with previous and future Safety Caps. No matter how your lab changes: Accessories and spare parts always fit. That is our promise for the future.

#### ✓ Trouble-Free Work

Safety Caps eliminate many interfering factors directly at the storage container. For smooth and reliable operation of your analytics.

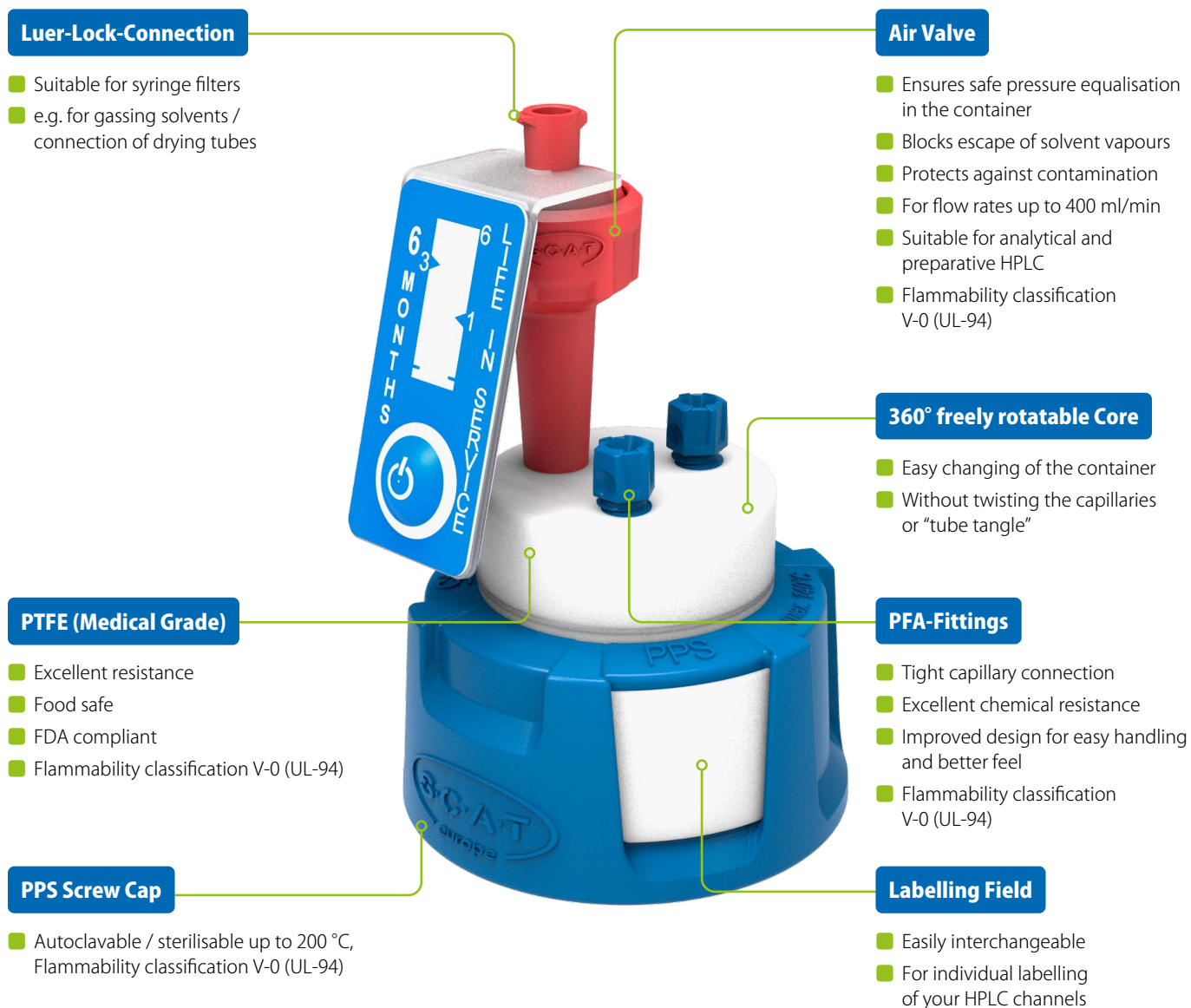
#### ✓ More than 25 Years of Practice

For continuous improvement, we work closely with users from all over the world. Ideas from daily laboratory practice flow directly into every new generation of Safety Caps. This way, you always remain at the cutting-edge of technology.



## Safety Caps

### Functional Principle



#### Various thread sizes

Safety Caps are available in many thread sizes to fit your storage container. Bottles with thread GL 45 are the most common in the HPLC laboratory. Caps in other sizes can be found here:

GL 45 Thread..... starting from **page 44**

Further Thread Sizes..... starting from **page 50**

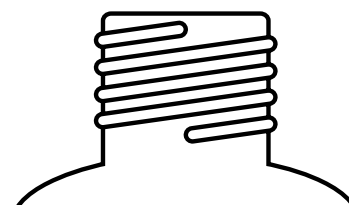
For Ground Neck Bottles..... **page 52**

Thread Adapters for further Threads .. starting from **page 164**

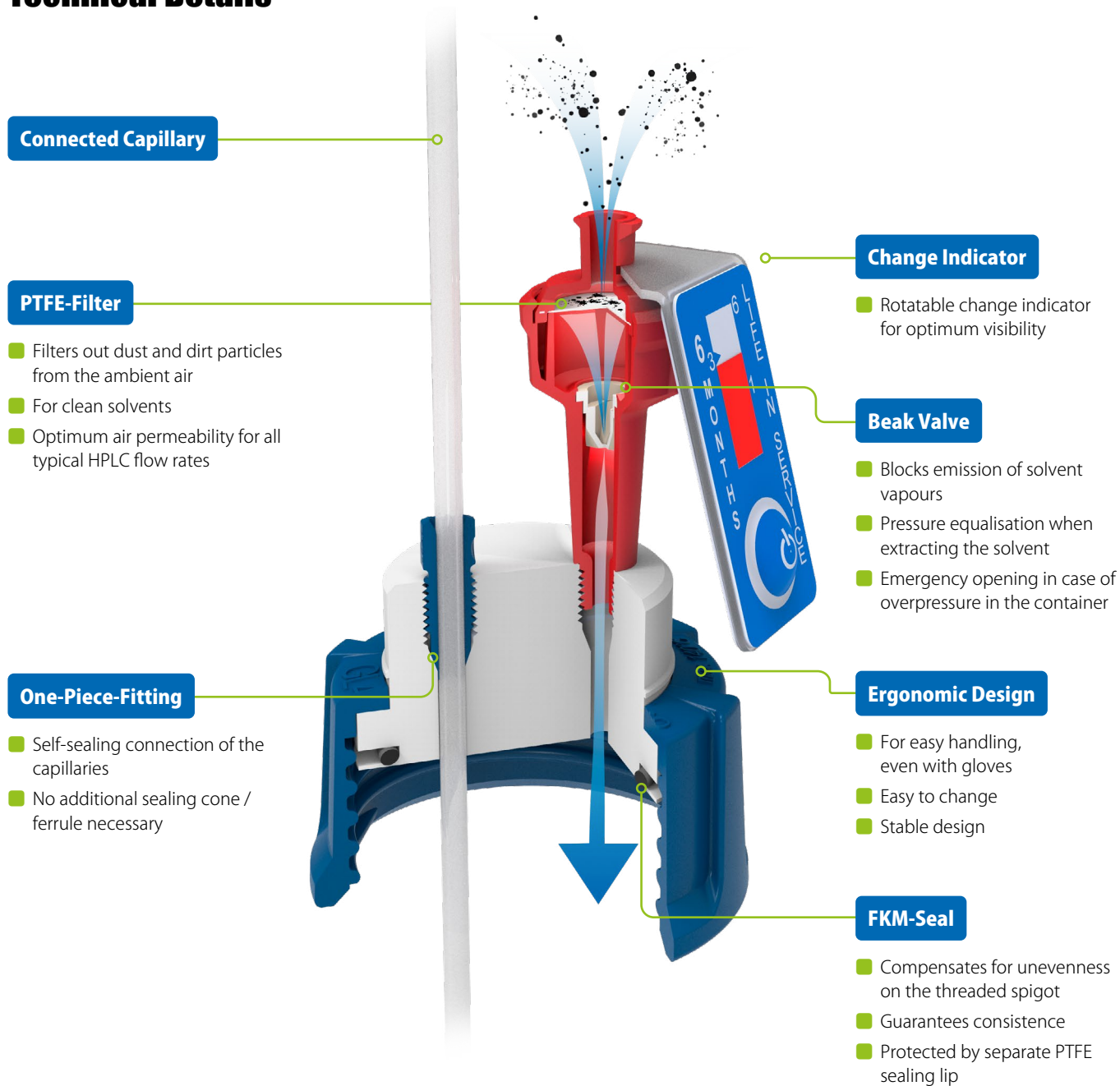


#### Which thread is the right one?

If you do not know the exact thread of your container, our chapter "Addendum" from "Thread Determination" onwards will help, on **page 172**.



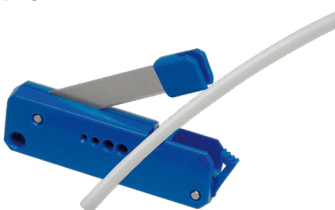
# Safety Caps Technical Details



Install your capillaries easily! The appropriate installation wrench you will find on **page 169**.



Cut capillaries neatly! You will find the appropriate tool on **page 169**.



### Accessories included!

Fittings and blind plugs in every size are included in the scope of delivery.

**ID** 1.6 mm 2.3 mm 3.2 mm X



Accessories in detail from **page 150**

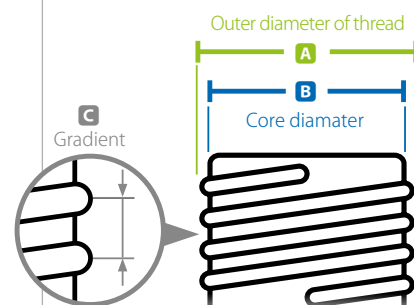
# Safety Caps GL 45 Thread

GL 45 is the most widely used thread for HPLC storage bottles. In most cases, bottles with a capacity of 500 or 1,000 ml are used. Solvents are often already supplied in bottles with this thread, or transferred to GL 45 bottles for HPLC supply.



## Thread information: GL 45

Informations to determinate threads starting from **page 172**.



Thread	Ø (mm) A	Ø (mm) B	(mm) C
GL 45	45.00	42.30	4.00



## Your benefits

- Great flexibility due to the maximum scope of delivery
- Fittings are colour coded according to inner diameter
- No annoying measuring of capillary sizes
- Unused connections can be closed with blind plugs

**A** 307 019



**B** 307 019-PP



## Accessories included!

Fittings and blind plugs in every size are included in the scope of delivery.

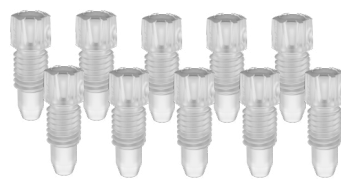
ID 1.6 mm 2.3 mm 3.2 mm X



Accessories in detail from **page 150**



**D** 160 501



Unused connections must be sealed with blind plugs!



## PP-Core

Our Safety Caps are available with a PP core on request. Here in the example: **B D**

Safety Caps with PP core are suitable for the analysis of polyfluorinated chemicals (PFC) according to DIN 38407-42 or 38414-14.

## Safety Caps State of the Art - Supply

 **GL 45**


Fig.	Part No.	Description	Thread	Material	Capillary Connections	Unit
<b>A</b>	307 019	Safety Cap I	GL 45	PTFE	1x	1
<b>B</b>	307 019-PP	Safety Cap I	GL 45	PP	1x	1
<b>C</b>	307 410	Safety Cap IV	GL 45	PTFE	4x	1
<b>D</b>	307 410-PP	Safety Cap IV	GL 45	PP	4x	1
<b>E</b>	307 909	Safety Cap II	GL 45	PTFE	2x	1
<b>F</b>	307 910	Safety Cap III	GL 45	PTFE	3x	1
<b>G</b>	307 520	Safety Cap VI	GL 45	PTFE	6x	1
<b>H</b>	317 010	Air valve for Safety Caps	UNF 1/4" 28G	-	-	1
	397 010	Air valves for Safety Caps	UNF 1/4" 28G	-	-	10
<b>I</b>	160 501	Blind plugs for Safety Caps	UNF 1/4" 28G	PFA	-	10

HPLC-Supply

HPLC-Disposal

Safety Funnels

Level Control

Containers

Accessory

Addendum



## Safety Caps The High-End-Model

 **GL 45**

### ✓ Quickly Ready for Use Again

Closing the shut-off ensures that no air gets into the capillaries or solvent runs out or drips when changing the container. After an interruption or repair, quick and easy flushing is possible.

### ✓ No Air Inclusions

After changing the storage reservoirs, the running analysis can be continued without interruption.

#### PFA Fitting

- One-Piece-Fitting
- Self-sealing connection of the capillaries
- No additional sealing cone / ferrule necessary

#### Shut-Off Valve (open)

- Trouble-free flow when open
- Quickly ready for use again after changing the container

#### PTFE Fitting

- Best chemical resistance

#### Eluent Flow Direction

- Towards the HPLC

#### Shut-Off Valve (sealed)

- Easy exchange of the container
- No air intakes in capillaries after changing storage containers
- Stops flow without coming into contact with capillaries



#### The Luer-adapter.

Easily add or remove liquids with the Luer adapter.  
More on **page 161**.



#### Looking for the right container?

Bottles, canisters and other containers, suitable with the SCAT Safety Caps starting from **page 130**.



# Safety Caps The High-End-Model

**GL 45**



**Accessories included!**

Fittings in every size are included in the scope of delivery.

**ID** 1.6 mm 2.3 mm 3.2 mm



Accessories in detail from **page 150**.



Fig.	Part No.	Description	Thread	Capillary Connections	from which with Shut-Off Valve
<b>A</b>	<b>307 919</b>	Safety Cap II with shut-off valves	GL 45	2x	2x
<b>B</b>	<b>307 920</b>	Safety Cap III with shut-off valves	GL 45	3x	3x
<b>C</b>	<b>307 419</b>	Safety Cap IV with shut-off valves	GL 45	4x	4x
<b>D</b>	<b>307 519</b>	Safety Cap VI with shut-off valves	GL 45	6x	6x

HPLC-Supply

HPLC-Disposal

Safety Funnels

Level Control

Containers

Accessory

Addendum

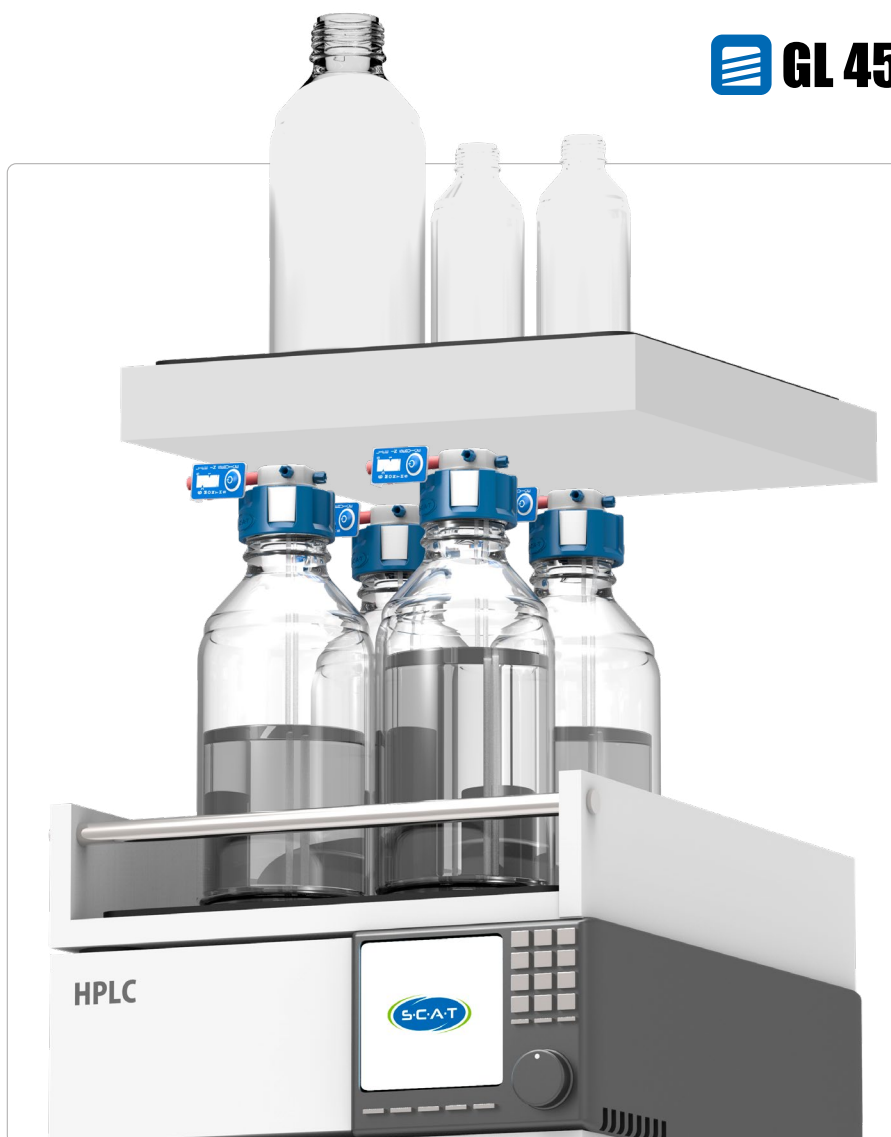


## Safety Caps Space-saving

 **GL 45**

### At a squeeze!

Especially where laboratory space is limited, you gain a major advantage with our angled Safety Caps. Even when extraction bottles are stored above the HPLC system, you can easily reach all the connectors because they are attached on the side.


**A** 399 019

**B** 399 909


Fig.	Part No.	Description	Thread	Capillary Connections
<b>A</b>	<b>399 019</b>	Safety Cap I 90° angled	GL 45	1x
<b>B</b>	<b>399 909</b>	Safety Cap II 90° angled	GL 45	2x

# Safety Caps For the Preparative HPLC



Safety Caps for larger capillary outer diameters (4.76 and 6.35 mm).



Fittings for other capillary sizes can be found from **page 156**.

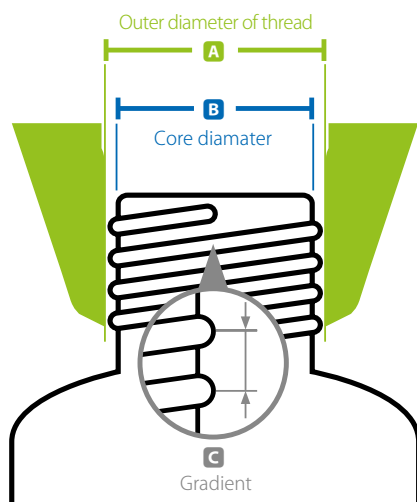
Fig.	Part No.	Description	Thread	Connections for Ø 1.6 / 2.3 / 3.2 mm OD (1/8 Inch)	Connections for Ø 4.76 mm OD (3/16 Inch)	Connections for Ø 6.35 mm OD (1/4 Inch)
	<b>307 003</b>	Safety Cap II preparative	GL 45	1x	1x	-
<b>A</b>	<b>307 007</b>	Safety Cap I preparative	GL 45	-	-	1x
<b>B</b>	<b>307 008</b>	Safety Cap II preparative	GL 45	-	-	2x
<b>C</b>	<b>307 009</b>	Safety Cap II preparative	GL 45	1x	-	1x
<b>D</b>	<b>308 032</b>	Safety Cap I preparative	GL 45	-	1x	-
<b>E</b>	<b>309 032</b>	Safety Cap II preparative	GL 45	-	2x	-
<b>F</b>	<b>310 032</b>	Safety Cap III preparative	GL 45	-	3x	-

## Safety Caps Further Thread Sizes



### Thread informations

Container threads can be roughly determined based on their diameter. Information on the exact determination of the thread can be found under "Thread determination" from **page 172**.



Thread	A Ø (mm)	B Ø (mm)	C (mm)
GL 28	28.00	25.98	3.00
GL 32	32.00	29.30	4.00
GL 38	38.00	35.00	3.00
38 / 430	37.49	35.10	4.23
GL / S 40	40.00	37.30	4.00
B 53	54.00	47.50	6.35
B 63	62.51	60.12	4.23
GLS 80	80.00	77.00	15P5
B 83	89.18	79.00	12.70

**A** 307 006


**GL 28**

**B** 107 511


**GL 32**

**C** 107 512


**GL 38**

**D** 107 636


**38 / 430**

**E** 107 637


**38 / 430**

**F** 107 105


**GL / S 40**

**G** 107 742


**GL / S 40**

**H** 307 100


**GL / S 40**


## Safety Caps Further Thread Sizes



**Accessories included!**  
Fittings and blind plugs in every size are included in the scope of delivery.

**ID** 1.6 mm 2.3 mm 3.2 mm X

Accessories in detail from [page 150](#)

Fig.	Part No.	Description	Thread	Capillary Connections
<b>A</b>	307 006	Safety Cap II	GL 28	2x
<b>B</b>	107 511	Safety Cap II	GL 32	2x
<b>C</b>	107 512	Safety Cap III	GL 38	3x
<b>D</b>	107 636	Safety Cap I	38 / 430	1x
<b>E</b>	107 637	Safety Cap II	38 / 430	2x
<b>F</b>	107 105	Safety Cap I, with shut-off valve	GL / S 40	1x
<b>G</b>	107 742	Safety Cap III	GL / S 40	3x
<b>H</b>	307 100	Safety Cap I	GL / S 40	1x
<b>I</b>	307 101	Safety Cap II	GL / S 40	2x
<b>J</b>	107 058	Safety Cap II	B 53	2x
<b>K</b>	107 039	Safety Cap I	B 63	1x
	107 030	Safety Cap I	GLS 80	1x
	107 031	Safety Cap II	GLS 80	2x
<b>L</b>	107 032	Safety Cap III	GLS 80	3x
<b>M</b>	107 035	Safety Cap IV	B 83	4x



## Safety Caps For Bottles with Ground Neck

 **NS 29/32**
**A** 107 607**B** 107 507**C** 307 508**D** 107 509**E** 107 506

### Easy Opening

Everyone is familiar with stuck ground neck stoppers: dried liquids and sticky substances settle on the ground glass, the stopper does not budge. SCAT stoppers with lock nut allow easy loosening and removal of the stopper even after a long standing time.

### **Locknut**


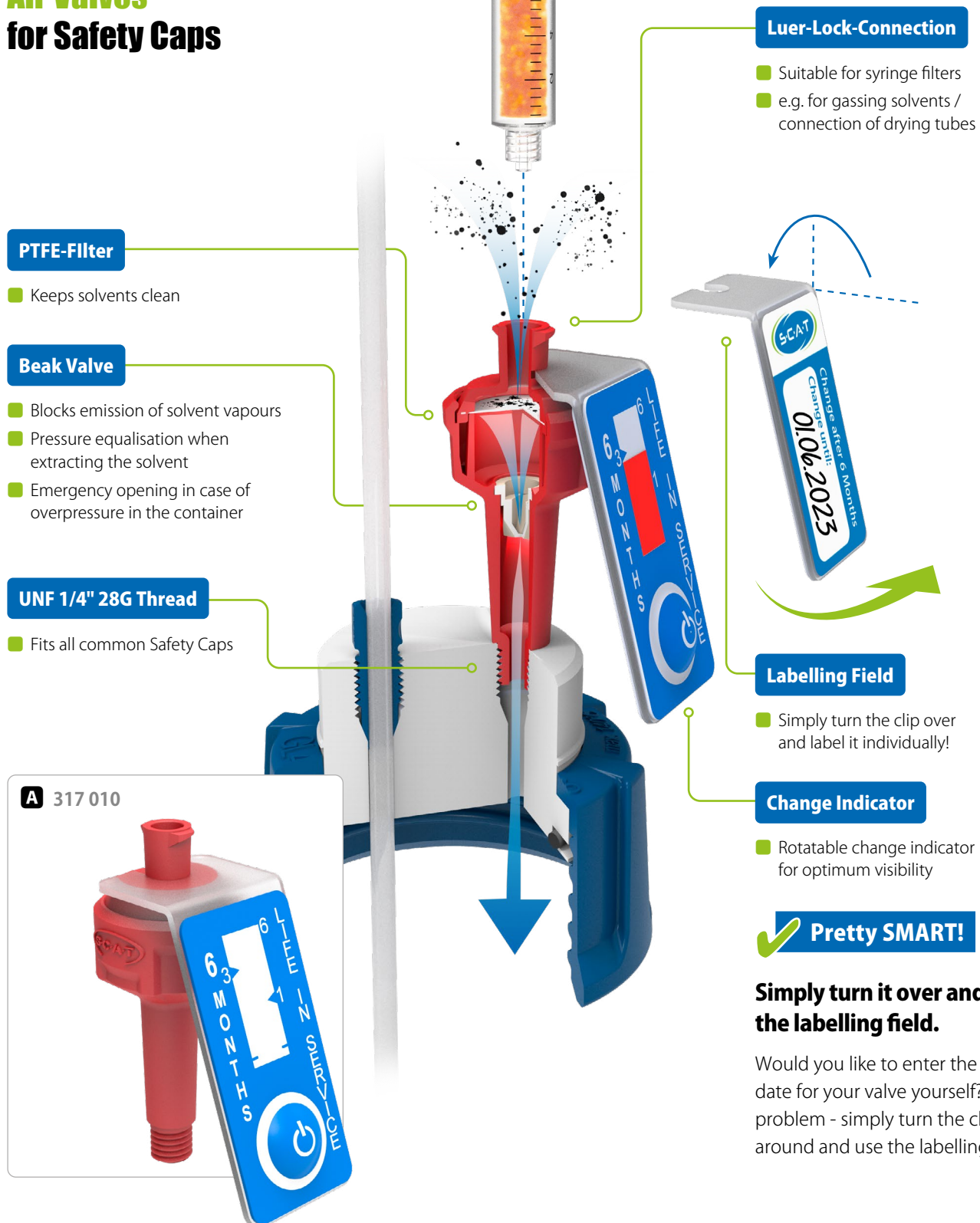
-  The locknut presses against the bottle when it is turned, thus releasing the cap without much effort



Fig.	Part No.	Description	Thread Size Ground Neck Size	Capillary Connection
<b>A</b>	<b>107 607</b>	Safety Cap II for ground neck bottles, with locknut	29/32 mm	2x
<b>B</b>	<b>107 507</b>	Blind plug for ground neck bottles, with locknut	29/32 mm	-
<b>C</b>	<b>307 508</b>	Ground neck adapter for GL 45 threaded bottles	GL 45 - 29/32 mm	-
<b>D</b>	<b>107 509</b>	GL 45 adapter for ground neck bottles, with locknut	29/32 mm - GL 45	-
<b>E</b>	<b>107 506</b>	Replacement locknut for Safety Cap	29/32 mm	-

# Air Valves for Safety Caps



### Luer-Lock-Connection

- Suitable for syringe filters
- e.g. for gassing solvents / connection of drying tubes

### PTFE-Filter

- Keeps solvents clean

### Beak Valve

- Blocks emission of solvent vapours
- Pressure equalisation when extracting the solvent
- Emergency opening in case of overpressure in the container

### UNF 1/4" 28G Thread

- Fits all common Safety Caps

### Labelling Field

- Simply turn the clip over and label it individually!

### Change Indicator

- Rotatable change indicator for optimum visibility

### ✓ Pretty SMART!

**Simply turn it over and use the labelling field.**

Would you like to enter the expiry date for your valve yourself? No problem - simply turn the clip around and use the labelling field.



Fig.	Part No.	Description	Thread Size	Unit
<b>A</b>	<b>317 010</b>	Air valve	UNF 1/4" 28G	1
	<b>397 008</b>	Air valves	UNF 1/4" 28G	8
	<b>397 010</b>	Air valves	UNF 1/4" 28G	10
	<b>397 050</b>	Air valves	UNF 1/4" 28G	50
	<b>397 100</b>	Air valves	UNF 1/4" 28G	100



# HPLC Starter Kits

## Savings: up to 30%

### ✓ Plug & Play for 4 Storage Bottles

Save yourself the trouble of putting together a configuration! The Starter Kits are available in 3 versions, suitable for most HPLC applications.

### ✓ Suitable for all common HPLC Systems

The starter kits work independently of the manufacturer of your HPLC. The connections are designed for capillaries with 1.6, 2.3 and 3.2 mm outer diameter.

### ✓ Flexible Connections with Blind Plugs

If you do not need some connections, close them with the corresponding blind plugs. This way, there are no open spots.

### ✓ Price Advantage

Price advantage compared to single order. Compared to single Safety Caps, the set is significantly cheaper. Request your individual offer: [www.scat-europe.com](http://www.scat-europe.com)



## HPLC Starter Kits



**A** 399 202



### Accessories included!

Fittings and blind plugs in every size are included in the scope of delivery.

**ID** 1.6 mm 2.3 mm 3.2 mm X



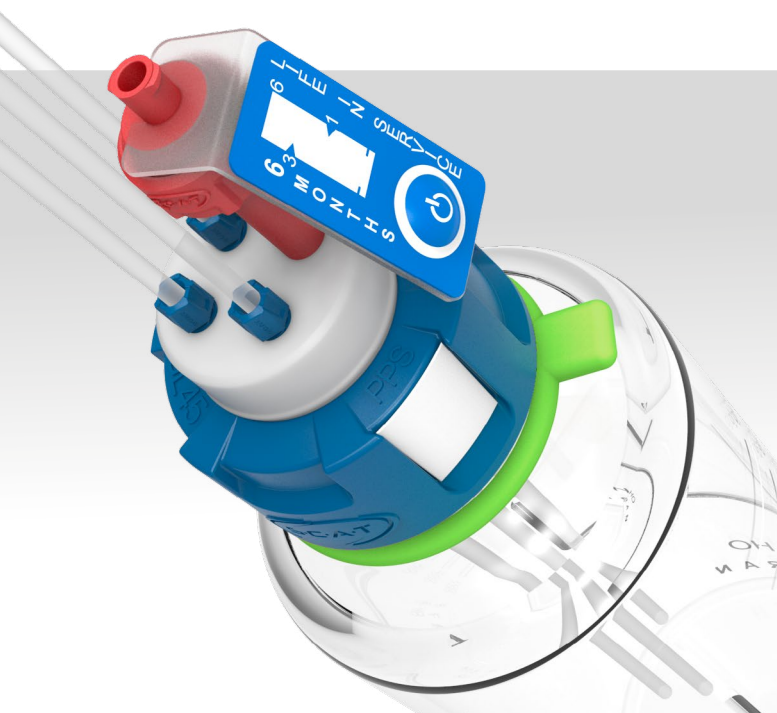
Accessories in detail from [page 150](#)

Abb.	Part No.	Description	Contents	Quantity	Thread	Capillary Connections
	<b>399 200</b>	<b>HPLC Starter Kit Supply 1</b>	Safety Cap I Safety Cap II Air valve Fitting (of each colour) Blind plug for capillary connection	3x 1x 4x 5x 1x	GL 45 GL 45 UNF 1/4" 28G UNF 1/4" 28G UNF 1/4" 28G	1x 2x - - -
	<b>399 201</b>	<b>HPLC Starter Kit Supply 2</b>	Safety Cap II Air valve Fitting (of each colour) Blind plug for capillary connection	4x 4x 8x 4x	GL 45 UNF 1/4" 28G UNF 1/4" 28G UNF 1/4" 28G	2x - - -
<b>A</b>	<b>399 202</b>	<b>HPLC Starter Kit Supply 3</b>	Safety Cap III Air valve Fitting (of each colour) Blind plug for capillary connection	4x 4x 12x 8x	GL 45 UNF 1/4" 28G UNF 1/4" 28G UNF 1/4" 28G	3x - - -

# HPLC Supply Sets

## Plug-and-Play Solution

These combinations are most frequently used by our customers. That is why we have put them together as practical sets. They contain all the necessary parts for connecting the solvent supply to your HPLC.



### ✓ Completely - Ready for Immediate Use

- With Safety Cap for safe supply
- Storage bottle in different versions
- For each connection: 1.5 m capillary with 3.2 mm outer diameter
- Suction filter made of PTFE for a particularly clean mobile phase



### Accessories included!

Capillaries, suction filters, as well as fittings in every size and blind plugs are included in the scope of delivery.



### ✓ Various Combinations

With 1, 2 or 3 HPLC connections. The storage bottles are available in clear or brown glass, round or square.

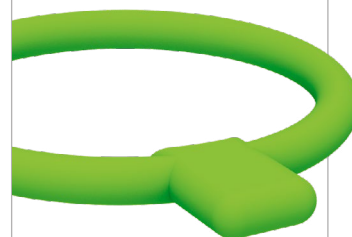
Fig.	Part No.	Description	Thread	Bottle Shape	Glass Type	Capacity	Capillary Connections
<b>A</b>	<b>307 300</b>	HPLC Supply Set I	GL 45	Round	Clear	1,000 ml	1x
<b>B</b>	<b>307 303</b>	HPLC Supply Set II	GL 45	Round	Clear	1,000 ml	2x
<b>C</b>	<b>307 304</b>	HPLC Supply Set III	GL 45	Round	Clear	1,000 ml	3x
<b>D</b>	<b>307 301</b>	HPLC Supply Set I	GL 45	Square	Clear	1,000 ml	1x
<b>E</b>	<b>307 305</b>	HPLC Supply Set II	GL 45	Square	Clear	1,000 ml	2x
<b>F</b>	<b>307 306</b>	HPLC Supply Set III	GL 45	Square	Clear	1,000 ml	3x
<b>G</b>	<b>307 312</b>	HPLC Supply Set I	GL 45	Round	Brown	1,000 ml	1x
<b>H</b>	<b>307 313</b>	HPLC Supply Set II	GL 45	Round	Brown	1,000 ml	2x
<b>I</b>	<b>307 314</b>	HPLC Supply Set III	GL 45	Round	Brown	1,000 ml	3x
<b>J</b>	<b>307 327</b>	HPLC Supply Set II	GL 28	Round	Brown	100 ml	2x
<b>K</b>	<b>307 347</b>	HPLC Supply Set III	GL 45	Ergonomic	Clear	1,000 ml	3x

## HPLC Supply Sets



### “Youtility” Bottle

With colour coding to identify your laboratory bottle. The coloured ring is easy to remove even when wearing gloves.





# HPLC Supply and Waste Set

## The All Inclusive Package



- ✓ Complete Package: All Parts Included
- ✓ Suitable for HPLC / UHPLC - Systems
- ✓ With Storage Bottle and Waste Container
- ✓ Unbox, Install - Ready

### The complete package for many device types

The HPLC supply and waste set offers complete safety for your HPLC or UHPLC system. It is ideal as basic equipment for most chromatography instruments and was developed in cooperation with leading instrument manufacturers. The large scope of delivery is designed for devices with up to 4 storage bottles and one waste container.

### Closed system for optimal protection

From the supply to your HPLC to the waste: air valves and exhaust filters block solvent vapours where they arise. The circulation of the liquids remains safe. Unused connections must be sealed with the supplied blind plugs. This way, there are no open spots.

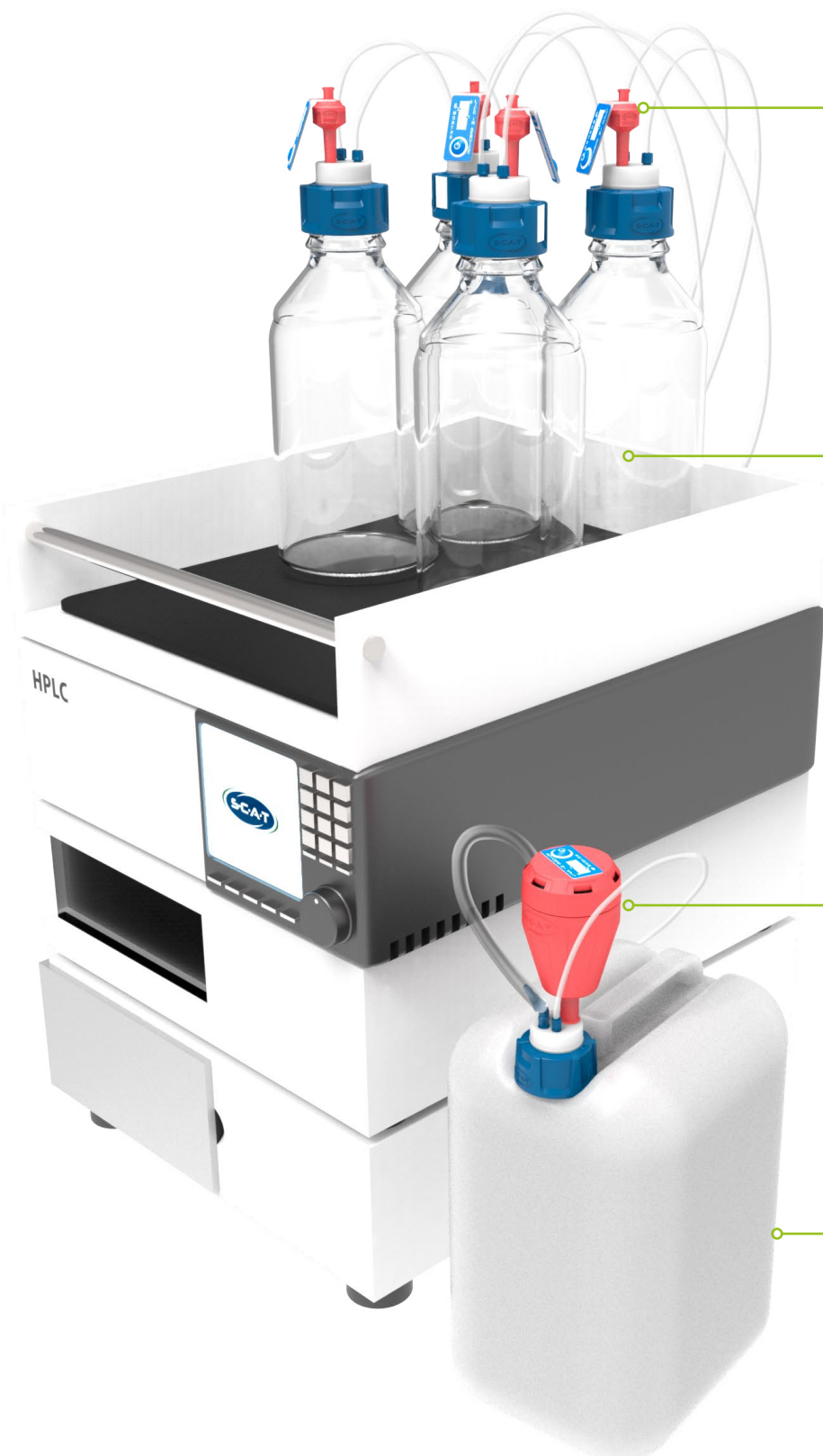


### Scope of delivery: what is included?

A detailed overview of all included parts can be found on **page 60**.

## HPLC Supply and Waste Set

### The All Inclusive Package



#### Safe Supply

- 4 Safety Caps with air valve
- For clean and safe extraction of the eluents
- 3 Connections for capillaries with  $\varnothing$  1.6 / 2.3 / 3.2 mm outer diameter at each cap
- Blind plugs for unused connections included

#### 4 Storage Bottles Included

- 1 Litre capacity with each bottle
- Clear glass with scale
- GL 45 Thread

#### Safe Disposal

- Safety Waste Cap blocks solvent vapours at the disposal
- Exhaust filter size M (6 months lifetime)
- Various filter sizes you will find on **page 71**

#### Collecting Canister Included

- 5 Litre capacity
- Chemical resistant PE-HD
- GL 45 Thread
- Various canisters in different sizes you will find starting from **page 136**



## HPLC Supply and Waste Set Scope of Delivery (307 337)

### Storage bottle

- GL 45 Thread
- Clear glass, round
- 1 Litre



4x

### Safety Cap III

- GL 45 Thread
- 3 Connections for  
Ø 1.6, 2.3 and 3.2 mm  
OD capillaries



4x

### Air valve

- Lifetime:  
6 months



4x

### Waste canister

- GL 45 Thread
- 5 Litre
- PE-HD



1x

### Safety Waste Cap

- GL 45 Thread
- 4 Connections for  
Ø 1.6, 2.3, 3.2 mm OD capillaries
- 1 Connection for Ø 5 - 11.5 mm  
ID tube



1x

### Exhaust filter

- Size M
- Lifetime:  
6 months



1x

### Fitting for capillary

- Ø 1.6 mm ID
- PFA, green



5x

### Fitting for capillary

- Ø 2.3 mm ID
- PFA, violet



5x

### Fitting for capillary

- Ø 3.2 mm ID
- PFA, blue



10x

### Blind plug for capillary connection

- PFA, colourless



10x

### Tube connector, stepped, curved

- Ø 5 - 11.5 mm OD
- PP, blue



1x

### Tube connector, straight

- Ø 6 - 8 mm OD
- PP, colourless



2x

### Tube connector, angled

- Ø 9.5 - 10 mm OD
- PP, colourless



1x

### Blind plug for tube connection

- PTFE, white



1x

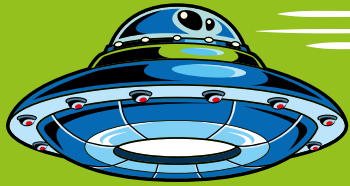
## HPLC Supply and Waste Set

### Ordering Information

**A** 307 337

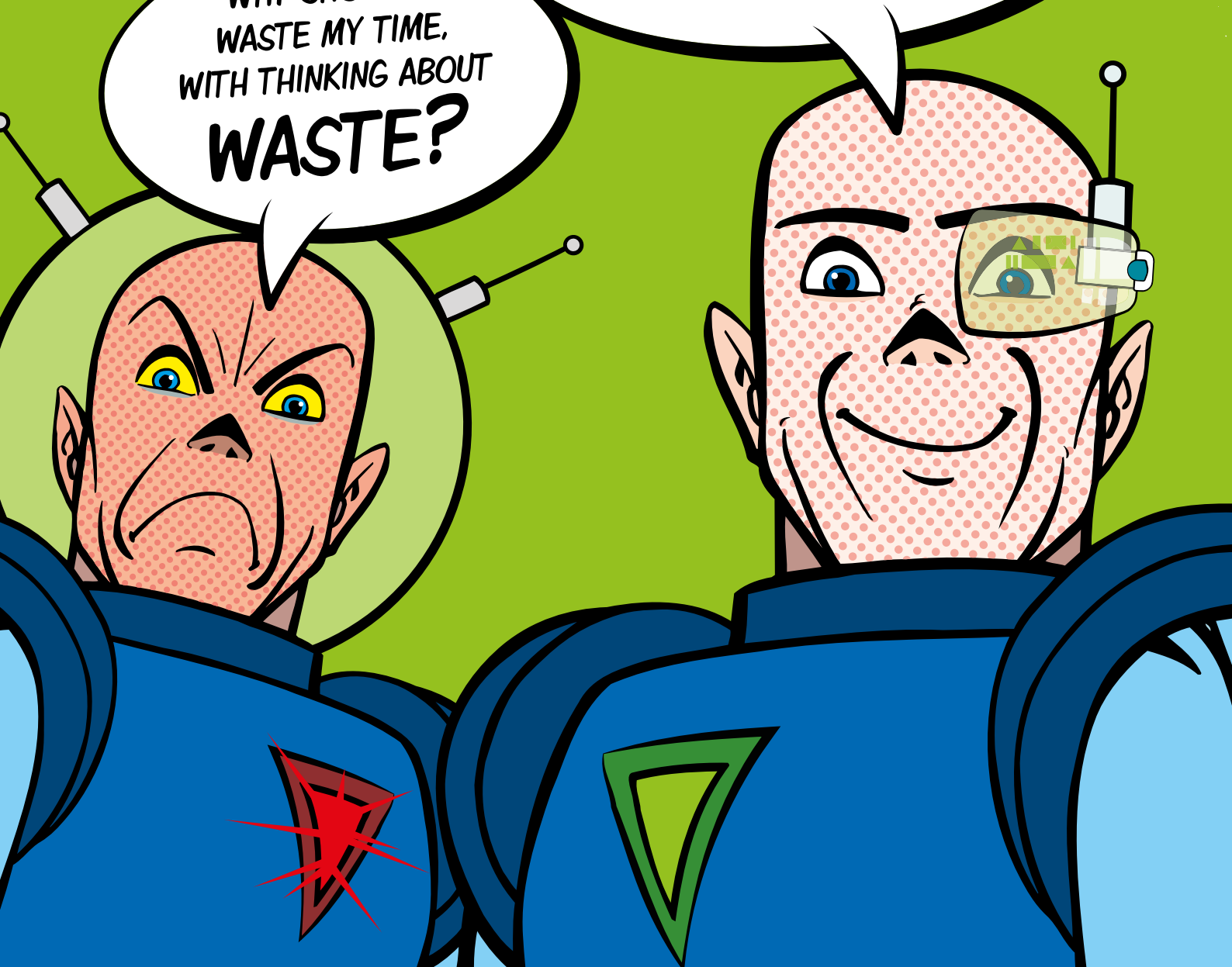


Fig.	Part No.	Description	Contents		
<b>A</b>	307 337	HPLC Supply and Waste Set	<b>Quantity</b>	<b>Description</b>	<b>See also</b>
			4x	Safety Cap III, GL 45	► Page 44
			1x	Safety Waste Cap, GL45	► Page 73
			4x	Air valve	► Page 53
			1x	Exhaust filter M, V3.0, with splash protection and change indicator	► Page 71
			4x	Laboratory bottle DURAN, GL 45, 1000 ml, clear glass, round	► Page 132
			1x	Canister, 5 Litres, PE-HD, GL 45	► Page 136
			5x	PFA Fitting, 1.6 mm ID, green	► Page 156
			5x	PFA Fitting, 2.3 mm ID, violet	► Page 156
			10x	PFA Fitting, 3.2 mm ID, blue	► Page 156
			1x	Tube connector, stepped, curved, 5.0 - 11.5 mm OD	► Page 158
			2x	Tube connector, straight, 6 - 8 mm OD	► Page 158
			1x	Tube connector, angled, 9.5 - 10 mm OD	► Page 158
			10x	Blind plug for capillary connection, PFA, colourless	► Page 156
1x	Blind plug for tube connection, PTFE, white	► Page 159			



BECAUSE YOU  
CAN BREATHE DEEPLY!  
TAKE A BREATH!

WHY SHOULD I  
WASTE MY TIME,  
WITH THINKING ABOUT  
**WASTE?**



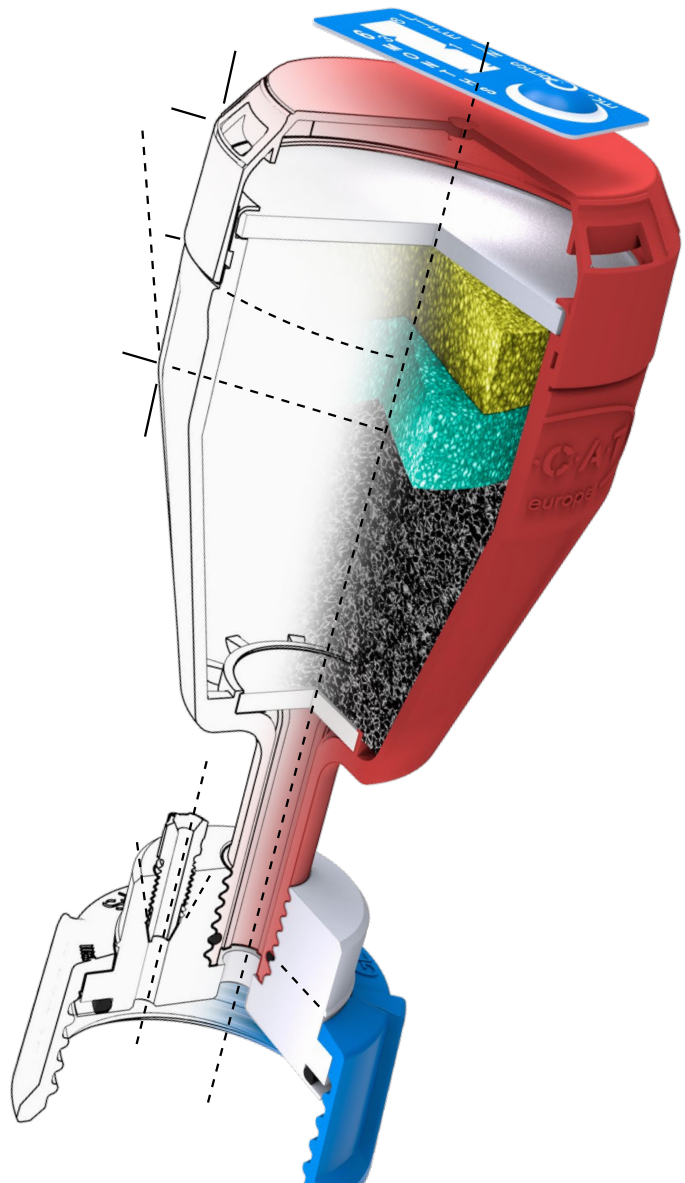
**Keep your Head clear -  
for your daily, Analytical  
Work.**

[www.scat-europe.com](http://www.scat-europe.com)

Working in the laboratory requires high concentration and a safe environment. Safety Waste Caps turn every collection container into a closed system according to the latest safety standards. This allows you to concentrate on your tasks undisturbed.

# HPLC-Disposal

- ✓ Bind Solvent Vapours Safely
- ✓ Safely Bind Acid and Alkaline Vapours
- ✓ Reliable Occupational Safety
- ✓ Clean Laboratory Air





# Do you Collect your HPLC-Waste Safely?

Safety Waste Caps - one system for all threads.

The liquids in the waste containers in laboratories are highly hazardous to health - users are often unaware of the mixtures that can arise in the canisters. Closed safety systems from SCAT Europe offer effective protection and additionally guarantee economical work in the laboratory.





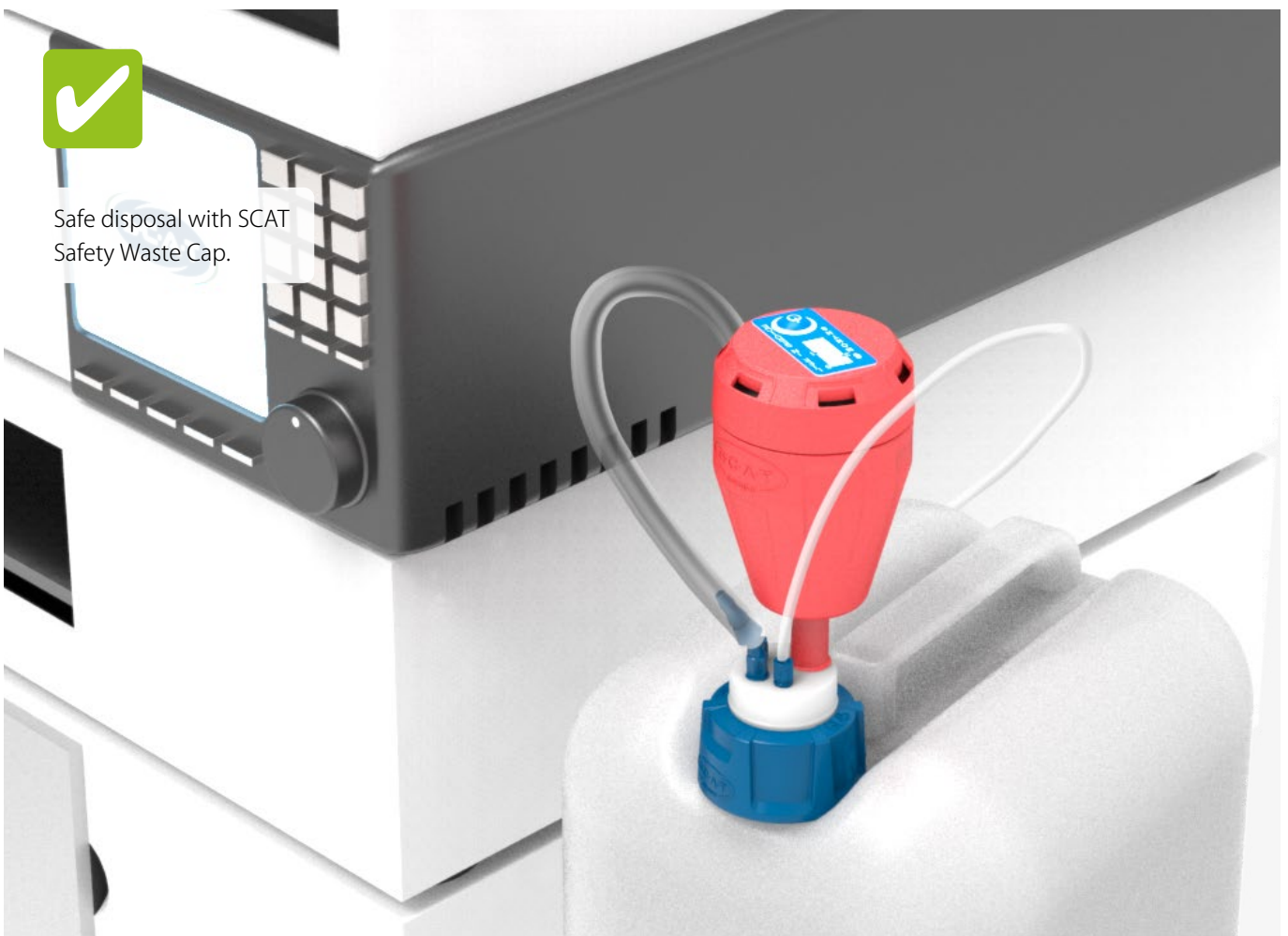
## You know This? Comparison



Improper disposal of laboratory waste.



Safe disposal with SCAT Safety Waste Cap.



# Activated Carbon: What is Important?

SCAT activated carbon protects against solvent, acid and alkali vapours.

## History

The beginnings of activated charcoal lie in the use of one of its predecessors in the production chain: charcoal! The first evidence that charcoal was used to purify water dates back to 200 BC. Chr.

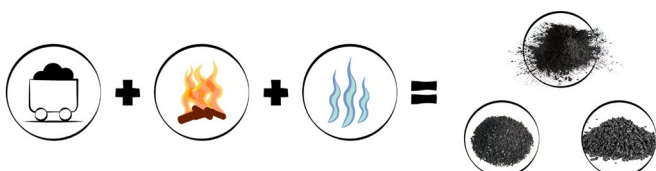
Columbus charred the insides of wooden barrels to increase the durability of the water being transported. The first industrial use of charcoal was in 1794 in an English sugar refinery.

## What is activated carbon?

Activated carbons are industrially (-> artificially) manufactured products from carbonaceous materials such as hard coal, lignite, wood, peat with a high internal, adsorptive surface. Activated carbon consists mainly of carbon (usually > 90%) with a highly porous structure. The pores are interconnected like a sponge.

## Manufacturing process

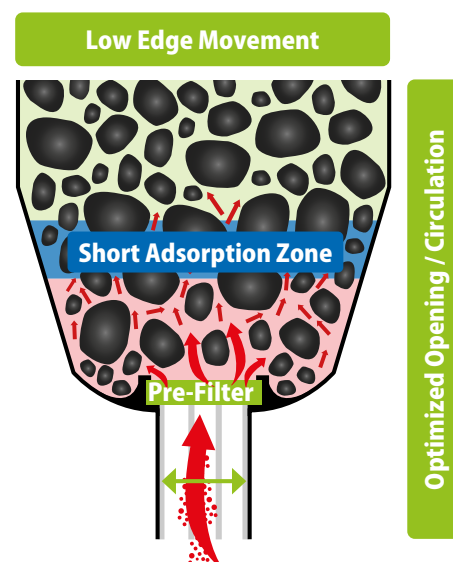
The starting material (hard coal, lignite, wood, peat,.. -> the primary coal) is charred, i.e. burned without oxygen supply. Almost everything that is not carbon is burned, resulting in a winding tunnel system with only very small pores. The raw activated carbon produced in this way is then activated. The active pore system is created by removing volatile components (hydrogen, oxygen, nitrogen, sulfur, etc.).



## Basic functionality

The fluid loaded with the pollutant flows through a layer of activated carbon at a certain speed, and releases the pollutant to the activated carbon. Any decrease in concentration of the fluid leads to an increase in the loading on the activated carbon. The activated carbon basically retains vaporous or dissolved substances only. Any dust or suspended matter must first be separated out by other filters (-> SCAT uses a pre-filter -> PE frit), otherwise they would contaminate the activated carbon.

Appropriate conductive devices inside the exhaust air filter housing must ensure that the fluid does not preferentially flow along the housing wall (-> flow resistance, problem of edge movement), but rather passes the activated carbon in the full cross-section.





## The SCAT specifications

No.	Attribute	Value	Test Method
1.	<b>Ball-Pan-Hardness</b> (% of weight)	96 %	ASTM D 3802
2.	<b>Inner Spec. Surface</b>	1,500 m <sup>2</sup> /g	DIN ISO 9277
3.	<b>Bulk Density</b>	415 ± 30 kg/m <sup>3</sup>	ASTM D 2854
4.	<b>CTC-Adsorption</b> (% of weight)	> 90 %	ASTM D 3467
5.	<b>Particle Diameter</b>	1.4 - 3 mm	ASTM D 2862
6.	<b>Ash Content</b> (% of weight)	max. 5 %	ASTM D 2866
7.	<b>Specific Humidity</b> (% of weight)	max. 5 %	ASTM D 2867

### 1. Ball-Pan-Hardness

The abrasion number measures the resistance of the activated carbon to wear. It is measured in the so-called ball pan hardness, according to ASTM D3802, in percent by weight. The principle is as follows: the activated carbon is placed on a vibrating screen. After 30 minutes, it is determined how many particles have fallen through the sieve. The fewer fall through, the better. I.e. the abrasion / "impact strength" etc. is higher. With a ball pan hardness of 96%, only 4% have fallen through.

### 2. Inner Specific Surface

The inner surface of porous or granular solids includes all of the surfaces they contain, including those between the individual grains or through the edges of the pores. Since all chemical reactions essentially depend on the "size of the attack" surface compared to the volume, the inner surface is of great importance.

### 3. Bulk Density

Density is mass per unit volume ( $\rho = m/V$ ). The density of gold is: 19,300 kg/m<sup>3</sup>. The density of pure carbon is 2,250 kg/m<sup>3</sup>. The tapped density (synonym: tapped density) is obtained by mechanically shaking or tapping the sample in a measuring cylinder until it no longer shows a significant reduction in volume. Basically, it can be said that the lower the fill density, the higher the porosity, and the higher the activation and quality of the activated carbon.

### 4. Adsorption

Adsorption refers to the absorption capacity (saturation) of the carbon. The adsorbed mass of pollutants is related to the mass of the fresh activated carbon and is called the loading. It is given in percent. With our activated carbon, the adsorption of CCl<sub>4</sub> (= carbon tetrachloride activity) is 90%. CCl<sub>4</sub> was defined by the activated carbon industry as a standard reference value with a net weight of 100 grams, the activated carbon weighs 190 grams when fully loaded - unique performance value!

### 5. Particle Diameter

The particle diameter describes the size of individual particles (also called grains) in a mixture. Depending on the application, a certain grain diameter is required. If the grain diameter is too small / powdery for our application, then sticking occurs that can only be overcome by high flow pressure.

### 6. Ash Content

In addition to carbon, activated carbon also contains inorganic components of the raw material that have not evaporated during production. Calcium, iron, zinc, copper, lead, chlorine, sulfate, phosphate, HCl-soluble substances and ash should be named here. Apart from the HCl-soluble substances (approx. 5%) and ash (approx. 10%), all other substances are below 0.5%. Since ash makes up the largest proportion, ash is often given as a reference value (the smaller the better). The ash consists mainly of silicon dioxide and aluminum. The amount depends on the base raw material used to produce the activated carbon. This means that the lower the ash content, the less ineffective minerals are in it and the more effective carbon.

### 7. Specific Humidity

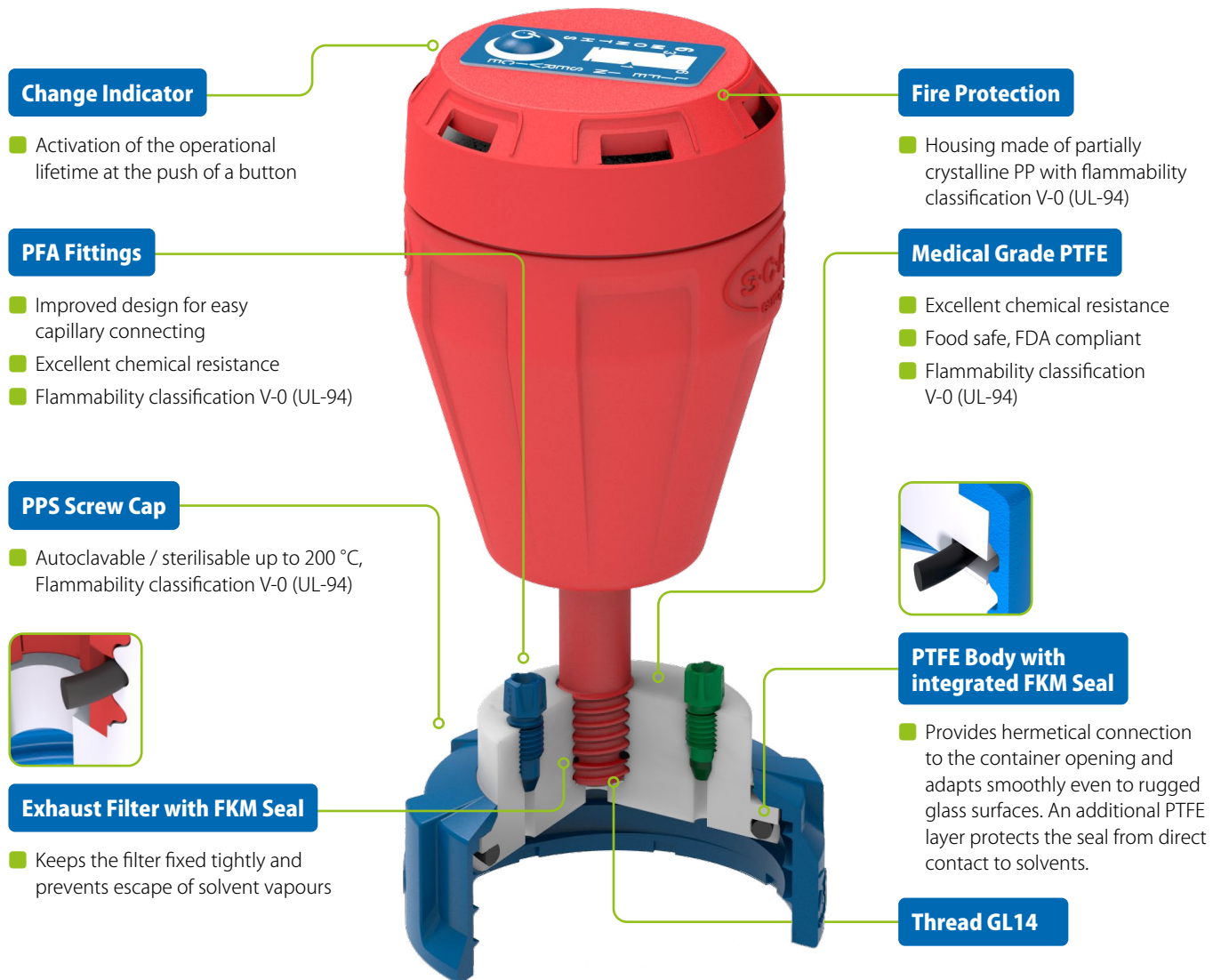
Specific humidity is measured as a percentage by weight. The lower the water content the better. You don't want water because it's ineffective. The ash content and the water content must be considered together. This means that a low ash content and low water content ensure that the activated carbon contains as much carbon as possible and a high level of effective activated carbon.

## Safety Waste Caps

### Functional Principle

#### ✓ Resistant to Aggressive Chemicals

Through the use of pure PTFE and PE-HD Safety Waste Caps are resistant to organic solvents, acids and alkalis.



#### Change Indicator

- Activation of the operational lifetime at the push of a button

#### PFA Fittings

- Improved design for easy capillary connecting
- Excellent chemical resistance
- Flammability classification V-0 (UL-94)

#### PPS Screw Cap

- Autoclavable / sterilisable up to 200 °C, Flammability classification V-0 (UL-94)



#### Exhaust Filter with FKM Seal

- Keeps the filter fixed tightly and prevents escape of solvent vapours

#### Fire Protection

- Housing made of partially crystalline PP with flammability classification V-0 (UL-94)

#### Medical Grade PTFE

- Excellent chemical resistance
- Food safe, FDA compliant
- Flammability classification V-0 (UL-94)



#### PTFE Body with integrated FKM Seal

- Provides hermetical connection to the container opening and adapts smoothly even to rugged glass surfaces. An additional PTFE layer protects the seal from direct contact to solvents.

#### Thread GL14



#### Consistent with Safety Waste Caps

Exhaust Filter.....	on page 71
Accessories for the exhaust filter conn. ....	on page 154
Accessories for the capillary connection ...	on page 156
Accessories for the tube connection .....	from page 158
Canisters.....	from page 136



#### What means fire protection according to UL-94?

In case of fire, each second counts. Flame resistant materials can save lives and provide rescue teams with more time to react in case of an emergency. UL-94 is an international standard to classify the flammability of plastics. UL-94 can also be found in IEC/DIN EN 60695-11-10 and -20. V-0 is the highest classification with the following requirements to the plastic material:

- Burning stops within 10 seconds on a vertically fixed specimen
- No drips of inflamed particles allowed
- Maximum afterglow of 30 seconds



# Safety Waste Caps Technical Details

## Functional Layers

- For yet more safety, there are three different types of active carbon (layered), offering a broad spectrum of capabilities, as well as more functions, e.g. HPLC buffer solutions are now also bound:
- Layer 3: binds acids
- Layer 2: binds alkalis
- Layer 1: adsorbs solvent vapours

## > 90% CTC-Adsorption

- The ability to bind has been increased by 20%!

## 1,500 m<sup>2</sup>/g

- The inner adsorption surface area has been increased by 25%!



## PE-Pre-Filter

- Protects the active carbon and provides optimal flow conditions for solvent vapours

## Signal Cable

- For the electronic level control a corresponding signal cable is already pre-installed

## PE-Filter Membrane

- Stabilizes the active carbon and provides proper air permeability

## Filtered Exhaust Air

## Grounding Connection

- A grounding cable with a banana plug can be easily connected to this grounding connection

## Liquid Waste

## Vapours/Gases

## Level Control

- Floater and sight glass. Mechanical or electronic, shows the filling level of the used container.



### Filter system against harmful vapours.

Exhaust filters in different sizes and with various operational lifetimes can be found on **page 71**.



### Do you already have the right container?

Use Safety Waste Caps on your existing containers, or order matching canisters! From **page 136**.



# The SCAT Exhaust Filter for Safety Waste Caps

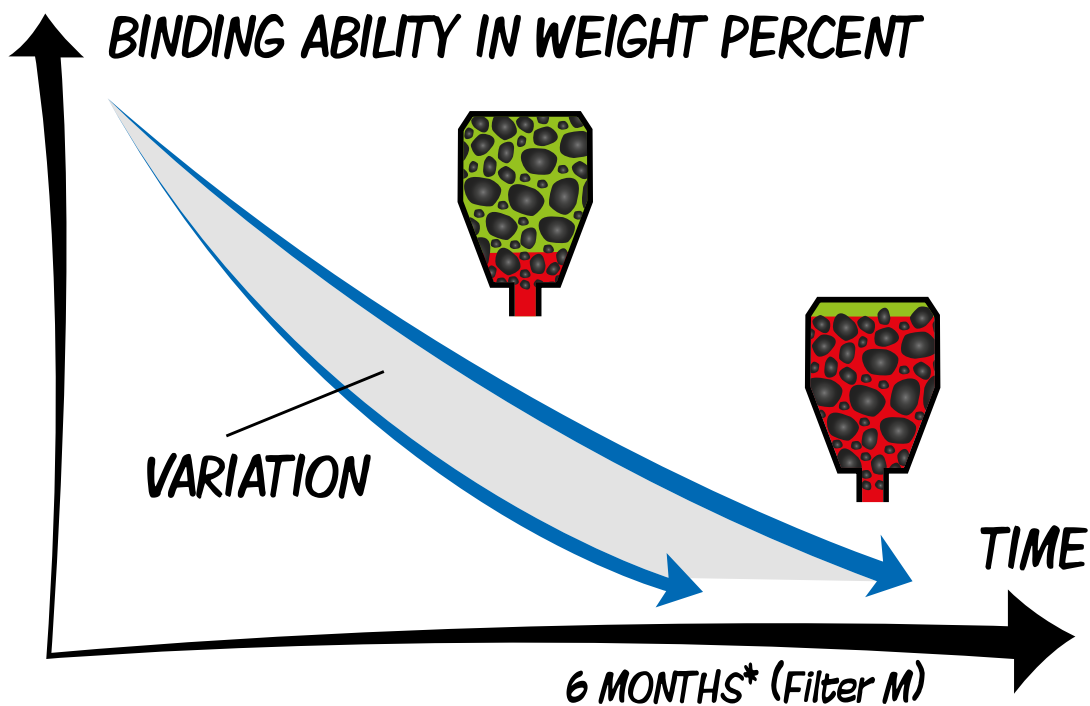
## Expended filters? - Exchange regularly!

The exhaust filter is optimized for the adsorption of solvent vapours from eluents, as typically used for HPLC. The actual lifetime of the filter is also dependent upon the composition of the waste material being produced, its temperature and flowrate. These factors can vary considerably from customer to customer, and/or according to the nature of the application. In order to be on the safe side, we recommend an exchange every 3 (Filter S); 6 (Filter M); 12 (Filter L) months\*, for optimum protection.



### Change indicator


Easy activation at the touch of a button!



\*Operational lifetime with typical HPLC flowrates of 1.5 - 4.0 ml per minute.

## The SCAT Exhaust Filter 12 Months of Safety


**A** 490 335



4x Exchange / Year

**Operational  
Lifetime**  
12  
**MONTHS**


**B** 490 336 - 19% \*\*



2x Exchange / Year

**Operational  
Lifetime**  
12  
**MONTHS**

**C** 407 986 - 33% \*\*



1x Exchange / Year

**Operational  
Lifetime**  
12  
**MONTHS**

\*\*As compared to the exchange pack, Size S.

Fig.	Part No.	Description	Thread	Lifetime per Unit	Unit
	<b>410 534</b>	Exhaust Filter S, V3.0, with splash protection and change indicator	GL 14	3 Months	1
<b>A</b>	<b>490 335</b>	Exhaust Filter S, V3.0, with splash protection and change indicator	GL 14	3 Months	4
	<b>407 982</b>	Exhaust Filter M, V3.0, with splash protection and change label	GL 14	6 Months	1
	<b>410 535</b>	Exhaust Filter M, V3.0, with splash protection and change indicator	GL 14	6 Months	1
<b>B</b>	<b>490 336</b>	Exhaust Filter M, V3.0, with splash protection and change indicator	GL 14	6 Months	2
	<b>490 914</b>	Exhaust Filter M, V3.0, with splash protection and change label	GL 14	6 Months	2
<b>C</b>	<b>407 986</b>	Exhaust Filter L, V3.0, with splash protection and change indicator	GL 14	12 Months	1
	<b>490 986</b>	Exhaust Filter L, V3.0, with splash protection and change indicator	GL 14	12 Months	2
	<b>407 983</b>	Exhaust Filter L, V3.0, with splash protection and change label	GL 14	12 Months	1
	<b>490 915</b>	Exhaust Filter L, V3.0, with splash protection and change label	GL 14	12 Months	2

HPLC-Supply

HPLC-Disposal

Safety Funnels

Level Control

Containers

Accessory

Addendum

# Safety Waste Caps

## State of the Art - Disposal

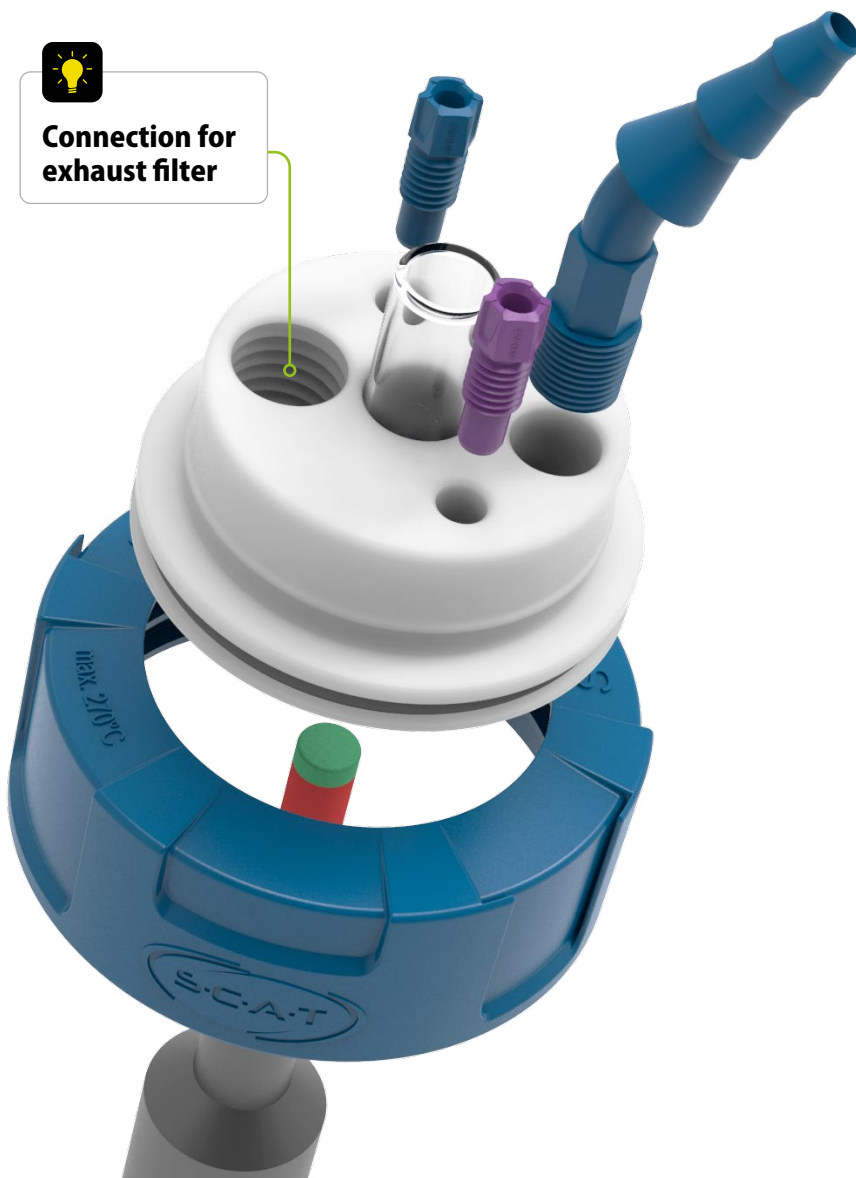


### Laboratory waste under lock.

With SCAT Safety Waste Caps you collect HPLC waste in the safest way possible. Suitable for many different containers, tube and capillary sizes, the SCAT Safety Waste Caps can be individually adapted to your laboratory equipment. With a mechanical or electronic level control you always have the best overview. The world's safest state-of-the-art system.

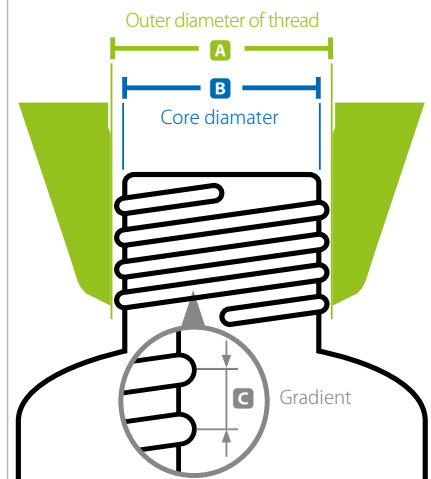


Connection for exhaust filter



### Thread informations

Container threads can be roughly determined based on their diameter. Information on the exact determination of the thread can be found under "Thread determination" from **page 172**.



Thread	A Ø (mm)	B Ø (mm)	C (mm)
GL 45	45.00	42.30	4.00
S 50	50.00	46.00	4.00
S 51	51.00	47.00	4.00
B 53	54.00	47.50	6.35
S 55	53.80	49.50	5.00
S 60	60.00	54.00	6.00
B 63	62.51	60.12	4.23
S 65	65.00	59.00	6.00
S 70	71.00	65.00	6.00
GLS 80	80.00	77.00	15P5
B 83	89.18	79.00	12.70
S 90	90.00	84.00	6.00
S 95	95.00	89.00	7.00

# Safety Waste Caps State of the Art - Disposal

## GL/S 40 - GL 45

**A** 307 108



**B** 307 109



**Don't forget - exhaust filter!**

Suitable exhaust filters with various operational lifetimes for SCAT Safety Waste Caps you will find on **page 71**.



**C** 307 912



**D** 307 923



**E** 308 921



Fig.	Part No.	Description	Thread	Capillary Connections	Tube Connections	Exhaust Filter Connection
<b>A</b>	<b>307 108</b>	Safety Waste Cap	GL/S 40	3	-	●
<b>B</b>	<b>307 109</b>	Safety Waste Cap	GL/S 40	2	1	●
<b>C</b>	<b>307 912</b>	Safety Waste Cap	GL 45	3	-	●
<b>D</b>	<b>307 923</b>	Safety Waste Cap	GL 45	2	1	●
<b>E</b>	<b>308 921</b>	Safety Waste Cap	GL 45	4	1	●

HPLC-Supply

HPLC-Disposal

Safety Funnels

Level Control

Containers

Accessory

Addendum

## Safety Waste Caps State of the Art - Disposal


**A** 108 023**B** 108 024**C** 108 025**D** 108 026**E** 108 113**F** 502 031

Fig.	Part No.	Description	Thread	Level Control	Capillary Connections	Tube Connections	Exhaust Filter Connection	Grounding Connection
<b>A</b>	<b>108 023</b>	Safety Waste Cap	S 50	-	3	-	●	-
<b>B</b>	<b>108 024</b>	Safety Waste Cap	S 50	-	3	-	●	●
<b>C</b>	<b>108 025</b>	Safety Waste Cap	S 50	-	2	1	●	-
<b>D</b>	<b>108 026</b>	Safety Waste Cap	S 50	-	2	1	●	●
<b>E</b>	<b>108 113</b>	Safety Waste Cap	S 50	-	3	1	●	-
<b>F</b>	<b>502 031</b>	Safety Waste Cap	S 50	-	5	-	●	-



# Safety Waste Caps State of the Art - Disposal

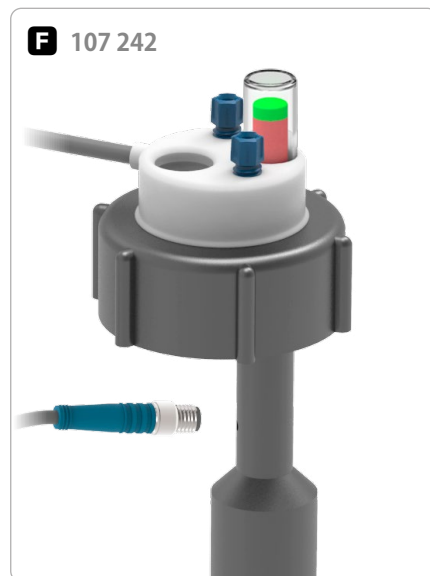
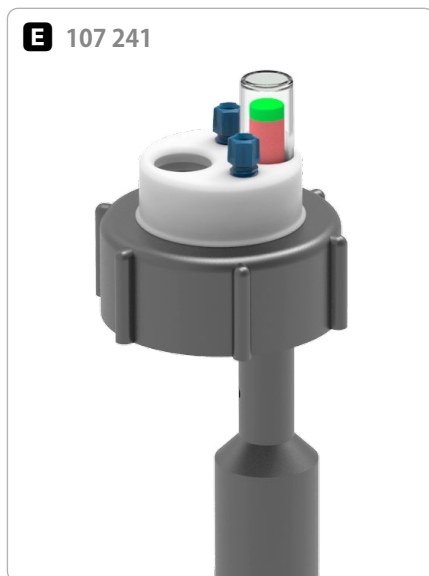
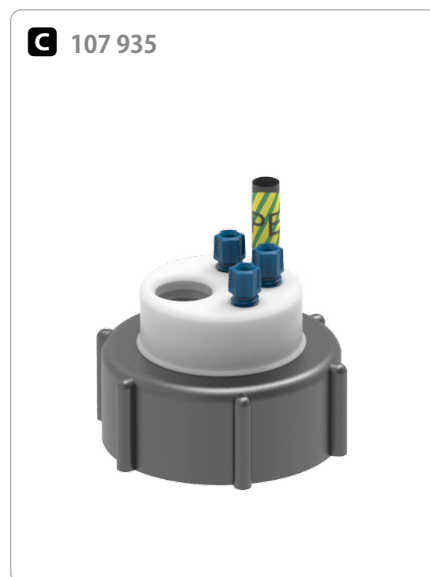
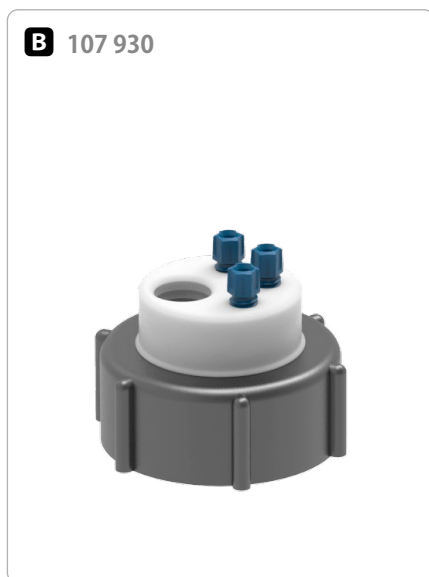


Fig.	Part No.	Description	Thread	Level Control	Capillary Connections	Tube Connections	Exhaust Filter Connection	Grounding Connection
<b>A</b>	<b>107 922</b>	Safety Waste Cap	S 51	-	2	1	●	-
<b>B</b>	<b>107 930</b>	Safety Waste Cap	S 51	-	3	-	●	-
<b>C</b>	<b>107 935</b>	Safety Waste Cap	S 51	-	3	-	●	●
<b>D</b>	<b>107 942</b>	Safety Waste Cap	S 51	-	2	1	●	●
<b>E</b>	<b>107 241</b>	Safety Waste Cap	S 51	Mechanical	2	-	●	-
<b>F</b>	<b>107 242</b>	Safety Waste Cap	S 51	Electronically	2	-	●	-

HPLC-Supply

HPLC-Disposal

Safety Funnels

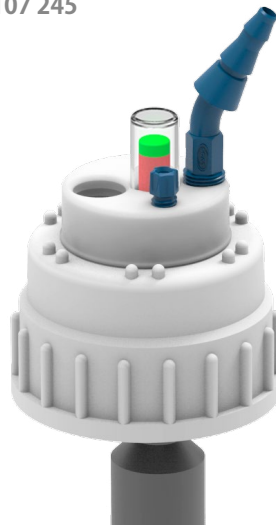
Level Control

Containers

Accessory

Addendum

## Safety Waste Caps State of the Art - Disposal

 **B 53**
**A** 107 037**B** 107 054**C** 107 120**D** 107 122**E** 107 245**F** 107 246

### Looking for the right container?

Canisters, bottles and other containers, suitable with the SCAT Safety Waste Caps starting from **page 130**.



Fig.	Part No.	Description	Thread	Level Control	Capillary Connections	Tube Connections	Exhaust Filter Connection	Grounding Connection
<b>A</b>	<b>107 037</b>	Safety Waste Cap	B 53	-	4	1	●	-
<b>B</b>	<b>107 054</b>	Safety Waste Cap	B 53	-	3	1	●	●
<b>C</b>	<b>107 120</b>	Safety Waste Cap	B 53	-	-	2	●	-
<b>D</b>	<b>107 122</b>	Safety Waste Cap	B 53	-	1	2	●	-
<b>E</b>	<b>107 245</b>	Safety Waste Cap	B 53	Mechanical	1	1	●	-
<b>F</b>	<b>107 246</b>	Safety Waste Cap	B 53	Electronically	1	1	●	-

# Safety Waste Caps State of the Art - Disposal



Fig.	Part No.	Description	Thread	Level Control	Capillary Connections	Tube Connections	Exhaust Filter Connection	Grounding Connection
<b>A</b>	107 121	Safety Waste Cap	S 55	-	-	2	●	-
	107 917	Safety Waste Cap	S 55	-	3	-	●	-
<b>B</b>	107 924	Safety Waste Cap	S 55	-	2	1	●	-
	107 936	Safety Waste Cap	S 55	-	3	-	●	●
<b>C</b>	107 943	Safety Waste Cap	S 55	-	2	1	●	●
	108 142	Safety Waste Cap	S 55	-	4	2	●	-
	108 143	Safety Waste Cap	S 55	-	1	2	●	-
<b>D</b>	108 177	Safety Waste Cap	S 55	-	4	1	●	-
	107 960	Safety Waste Cap	S 55	Mechanical	3	-	●	-
	107 963	Safety Waste Cap	S 55	Mechanical	2	1	●	-
<b>E</b>	108 030	Safety Waste Cap	S 55	Mechanical	3	-	●	●
	108 200	Safety Waste Cap	S 55	Electronically	3	-	●	-
<b>F</b>	108 201	Safety Waste Cap	S 55	Electronically	2	1	●	-

HPLC-Supply

HPLC-Disposal

Safety Funnels

Level Control

Containers

Accessory

Addendum

## Safety Waste Caps State of the Art - Disposal

 **S 60/61**
**A** 307 916**B** 307 925**C** 307 931**D** 307 500**E** 307 964**F** 308 403

Fig.	Part No.	Description	Thread	Level Control	Capillary Connections	Tube Connections	Exhaust Filter Connection	Grounding Connection
<b>A</b>	<b>307 916</b>	Safety Waste Cap	S 60/61	-	3	-	●	●
	<b>307 918</b>	Safety Waste Cap	S 60/61	-	3	-	●	-
<b>B</b>	<b>307 925</b>	Safety Waste Cap	S 60/61	-	2	1	●	-
<b>C</b>	<b>307 931</b>	Safety Waste Cap	S 60/61	-	4	1	●	-
	<b>307 944</b>	Safety Waste Cap	S 60/61	-	2	1	●	●
	<b>307 961</b>	Safety Waste Cap	S 60/61	Mechanical	3	-	●	-
<b>D</b>	<b>307 500</b>	Safety Waste Cap	S 60/61	-	3	3	●	-
<b>E</b>	<b>307 964</b>	Safety Waste Cap	S 60/61	Mechanical	2	1	●	-
	<b>308 961</b>	Safety Waste Cap	S 60/61	Mechanical	3	-	●	●
	<b>308 964</b>	Safety Waste Cap	S 60/61	Mechanical	2	1	●	●
	<b>308 402</b>	Safety Waste Cap	S 60/61	Electronically	3	-	●	●
<b>F</b>	<b>308 403</b>	Safety Waste Cap	S 60/61	Electronically	2	1	●	-

# Safety Waste Caps State of the Art - Disposal



### Don't forget - exhaust filter!

Suitable exhaust filters with various operational lifetimes for SCAT Safety Waste Caps you will find on **page 71**.



Fig.	Part No.	Description	Thread	Level Control	Capillary Connections	Tube Connections	Exhaust Filter Connection	Grounding Connection
<b>A</b>	<b>107 038</b>	Safety Waste Cap	B 63	-	1	3	●	-
<b>B</b>	<b>107 050</b>	Safety Waste Cap	B 63	-	2	1	●	-
<b>C</b>	<b>107 051</b>	Safety Waste Cap	B 63	-	3	-	●	-
<b>D</b>	<b>107 247</b>	Safety Waste Cap	B 63	Mechanical	2	1	●	-
<b>E</b>	<b>107 248</b>	Safety Waste Cap	B 63	Electronically	2	1	●	-

HPLC-Supply

HPLC-Disposal

Safety Funnels

Level Control

Containers

Accessory

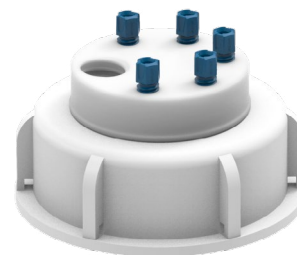
Addendum



## Safety Waste Caps State of the Art - Disposal


**A** 108 047

**B** 108 055

**C** 108 046

**D** 107 968

**E** 107 969

**F** 108 203


### Signalboxes for electronic level control.

Catch the signal from your Safety Waste Cap with electronic level control. Signalboxes you will find on **page 125**.



Fig.	Part No.	Description	Thread	Level Control	Capillary Connections	Tube Connections	Exhaust Filter Connection	Grounding Connection
<b>A</b>	<b>108 047</b>	Safety Waste Cap	S 65	-	4	1	●	-
<b>B</b>	<b>108 055</b>	Safety Waste Cap	S 65	-	4	1	●	●
<b>C</b>	<b>108 046</b>	Safety Waste Cap	S 65	-	5	-	●	-
<b>D</b>	<b>107 968</b>	Safety Waste Cap	S 65	Mechanical	4	-	●	-
<b>E</b>	<b>107 969</b>	Safety Waste Cap	S 65	Mechanical	4	1	●	-
<b>F</b>	<b>108 203</b>	Safety Waste Cap	S 65	Electronically	2	1	●	-

# Safety Waste Caps State of the Art - Disposal



### Looking for the right container?

Canisters, bottles and other containers, suitable with the SCAT Safety Waste Caps starting from **page 130**.



Fig.	Part No.	Description	Thread	Level Control	Capillary Connections	Tube Connections	Exhaust Filter Connection	Grounding Connection
	<b>107 913</b>	Safety Waste Cap	S 70/71	-	3	-	●	-
<b>A</b>	<b>107 915</b>	Safety Waste Cap	S 70/71	-	3	-	●	●
<b>B</b>	<b>107 926</b>	Safety Waste Cap	S 70/71	-	2	1	●	-
<b>C</b>	<b>107 945</b>	Safety Waste Cap	S 70/71	-	2	1	●	●
<b>D</b>	<b>107 962</b>	Safety Waste Cap	S 70/71	Mechanical	3	-	●	-
<b>E</b>	<b>107 965</b>	Safety Waste Cap	S 70/71	Mechanical	2	1	●	-
<b>F</b>	<b>108 407</b>	Safety Waste Cap	S 70/71	Electronically	2	1	●	-

HPLC-Supply

HPLC-Disposal

Safety Funnels

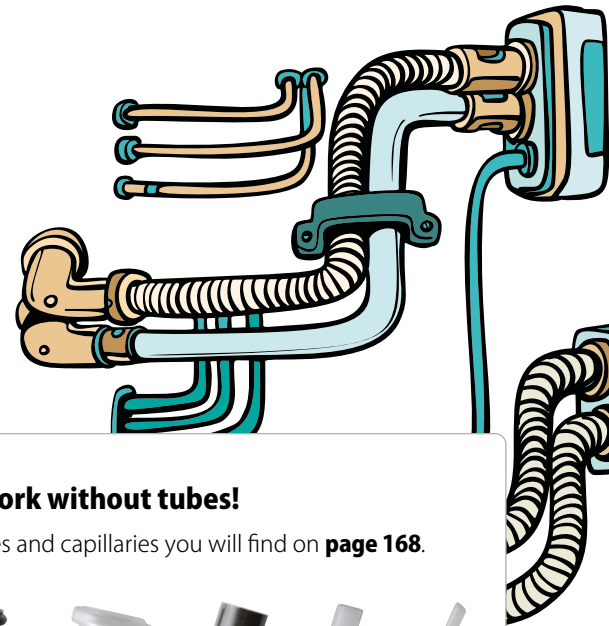
Level Control

Containers

Accessory

Addendum

## Safety Waste Caps State of the Art - Disposal


**GLS 80**
**A** 107 029

**It won't work without tubes!**

 Suitable tubes and capillaries you will find on **page 168**.

**B** 107 033

**C** 108 206


Fig.	Part No.	Description	Thread	Level Control	Capillary Connections	Tube Connections	Exhaust Filter Connection	Grounding Connection
<b>A</b>	<b>107 029</b>	Safety Waste Cap	GLS 80	-	4	-	●	-
<b>B</b>	<b>107 033</b>	Safety Waste Cap	GLS 80	-	4	1	●	-
<b>C</b>	<b>108 206</b>	Safety Waste Cap	GLS 80	Electronically	-	1	●	-

# Safety Waste Caps State of the Art - Disposal



### Looking for the right container?

Canisters, bottles and other containers, suitable with the SCAT Safety Waste Caps starting from **page 130**.



Fig.	Part No.	Description	Thread	Level Control	Capillary Connections	Tube Connections	Exhaust Filter Connection	Grounding Connection
<b>A</b>	<b>107 034</b>	Safety Waste Cap	B 83	-	4	1	●	-
	<b>107 036</b>	Safety Waste Cap	B 83		4	-	●	-
<b>B</b>	<b>107 052</b>	Safety Waste Cap	B 83	-	4	-	●	●
<b>C</b>	<b>107 053</b>	Safety Waste Cap	B 83	-	4	1	●	●
<b>D</b>	<b>108 156</b>	Safety Waste Cap	B 83	Mechanical	4	1	●	-
<b>E</b>	<b>108 302</b>	Safety Waste Cap	B 83	Mechanical	8	2	●	-
<b>F</b>	<b>108 205</b>	Safety Waste Cap	B 83	Electronically	4	1	●	-

HPLC-Supply

HPLC-Disposal

Safety Funnels

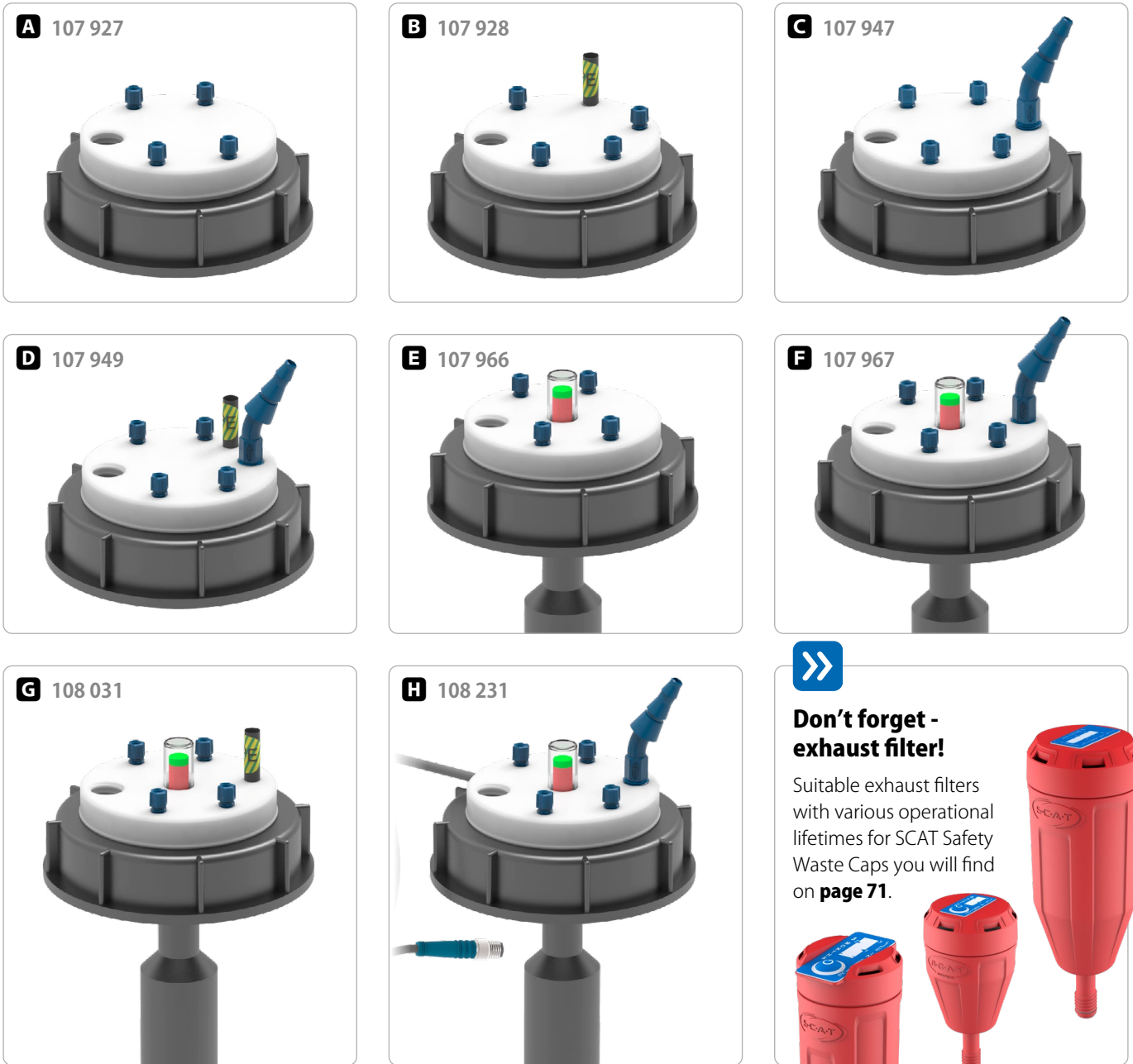
Level Control

Containers

Accessory

Addendum

## Safety Waste Caps State of the Art - Disposal

 **S 90**


### Don't forget - exhaust filter!

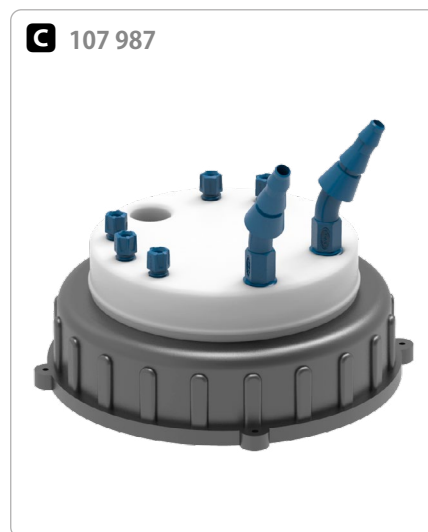
Suitable exhaust filters with various operational lifetimes for SCAT Safety Waste Caps you will find on **page 71**.



Fig.	Part No.	Description	Thread	Level Control	Capillary Connections	Tube Connections	Exhaust Filter Connection	Grounding Connection
<b>A</b>	<b>107 927</b>	Safety Waste Cap	S 90	-	4	-	●	-
<b>B</b>	<b>107 928</b>	Safety Waste Cap	S 90	-	4	-	●	●
<b>C</b>	<b>107 947</b>	Safety Waste Cap	S 90	-	4	1	●	-
<b>D</b>	<b>107 949</b>	Safety Waste Cap	S 90	-	4	1	●	●
<b>E</b>	<b>107 966</b>	Safety Waste Cap	S 90	Mechanical	4	-	●	-
<b>F</b>	<b>107 967</b>	Safety Waste Cap	S 90	Mechanical	4	1	●	-
<b>G</b>	<b>108 031</b>	Safety Waste Cap	S 90	Mechanical	4	-	●	●
<b>H</b>	<b>108 231</b>	Safety Waste Cap	S 90	Electronically	4	1	●	-



# Safety Waste Caps State of the Art - Disposal



### Signalboxes for electronic level control.

Catch the signal from your Safety Waste Cap with electronic level control. Signalboxes you will find on **page 125**.



Fig.	Part No.	Description	Thread	Level Control	Capillary Connections	Tube Connections	Exhaust Filter Connection	Grounding Connection
<b>A</b>	<b>107 256</b>	Safety Waste Cap	S 95	-	4	-	●	-
<b>B</b>	<b>107 257</b>	Safety Waste Cap	S 95	-	4	1	●	-
<b>C</b>	<b>107 987</b>	Safety Waste Cap	S 95	-	5	2	●	-
<b>D</b>	<b>117 987</b>	Safety Waste Cap	S 95	-	12	-	●	-
<b>E</b>	<b>107 258</b>	Safety Waste Cap	S 95	Mechanical	4	1	●	-
<b>F</b>	<b>107 259</b>	Safety Waste Cap	S 95	Electronically	4	1	●	-

# HPLC Disposal Sets

## The Plug-and-Play Solution

Safety Waste Cap, canister, exhaust air filter and comprehensive accessories combined in a HPLC disposal set for direct start-up of your disposal.

### HPLC Disposal Set

#### Scope of Delivery (307 307)

##### Waste canister

- GL 45 Thread
- 5 Litres
- PE-HD



1x

##### Safety Waste Cap

- GL 45 Thread
- 2x Capillary connection
- 1x Tube connection
- 1x Exhaust filter connection



1x

##### Exhaust filter

- Size M
- Operational lifetime: 6 months



1x

##### Tube connector, stepped, curved

- Ø 5 - 11.5 mm OD
- PP, blue



1x

##### Fitting for capillaries

- Ø 2.3 mm ID
- PFA, violet



2x

##### Fitting for capillaries

- Ø 3.2 mm ID
- PFA, blue



2x

##### Blind plug for capillary connection

- PFA, colourless



2x

# HPLC Disposal Sets

**A** 307 307



Fig.	Part No.	Description	Contents		
<b>A</b>	<b>307 307</b>	HPLC Disposal Set 1	<b>Quantity</b>	<b>Description</b>	<b>See also</b>
			1x	Safety Waste Cap, GL 45 (307 923)	► Page 73
			1x	5 Litre canister, PE-HD (107 951)	► Page 136
	<b>307 310</b>	HPLC Disposal Set 2	<b>Quantity</b>	<b>Description</b>	<b>See also</b>
			1x	Safety Waste Cap, GL 45 (307 923)	► Page 73
			1x	10 Litre canister, PE-HD (107 952)	► Page 136
	<b>307 328</b>	HPLC Disposal Set 3	<b>Quantity</b>	<b>Description</b>	<b>See also</b>
			1x	Safety Waste Cap, S 50 (108 025)	► Page 74
			1x	5 Litre space-saving canister, PP (107 998)	► Page 136
	<b>307 355</b>	HPLC Disposal Set 4	<b>Quantity</b>	<b>Description</b>	<b>See also</b>
			1x	Safety Waste Cap, S 60/61 (307 925)	► Page 78
			1x	12 Litres canister, PE-HD (107 731)	► Page 138
			1x	Exhaust filter M (410 535)	► Page 71

HPLC-Supply

HPLC-Disposal

Safety Funnels

Level Control

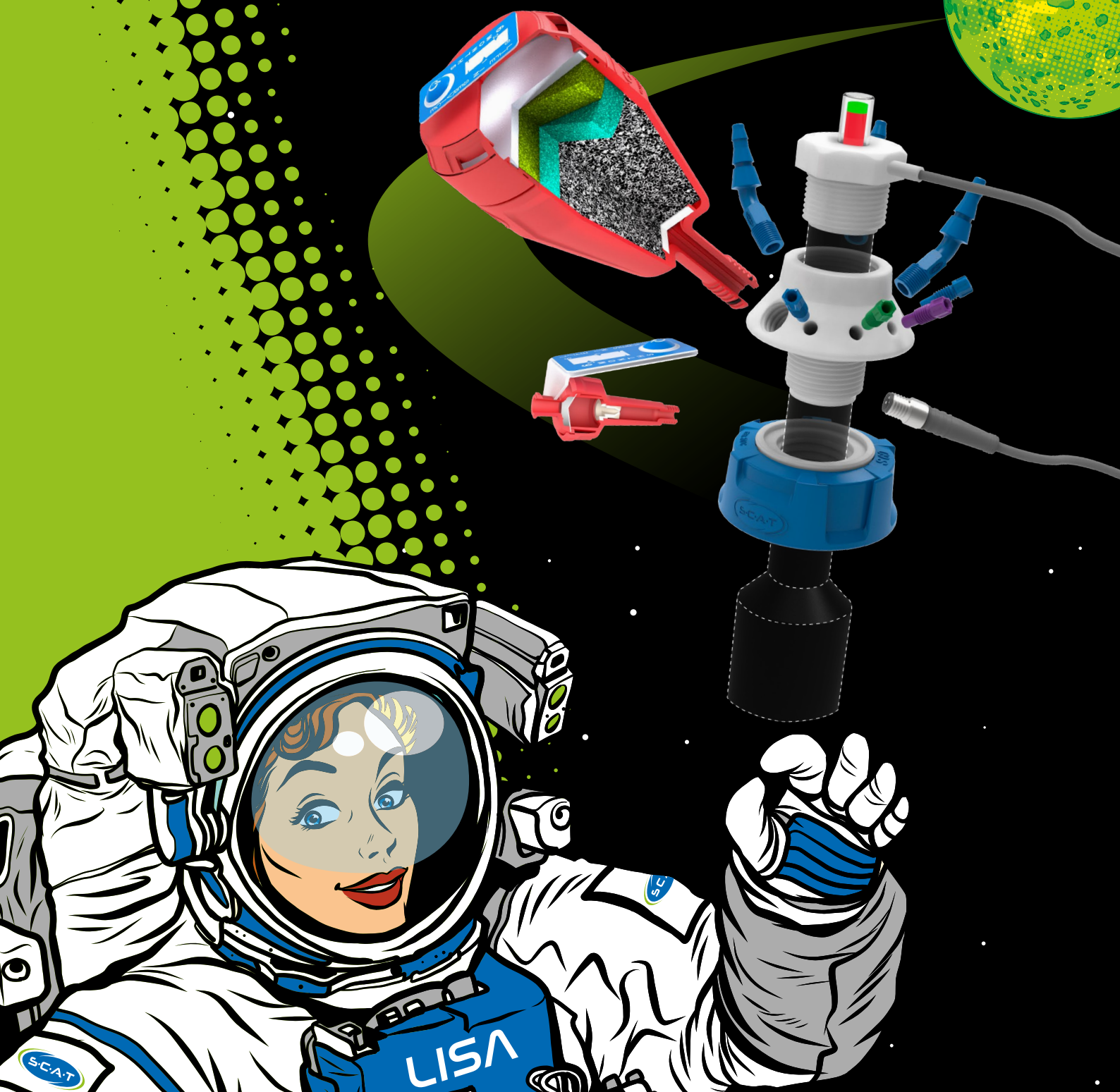
Containers

Accessory

Addendum

# LISA Safety Waste Cap

Collect HPLC / UHPLC waste safely.





# LISA Technical Details

### Blind Plug

- In addition to blind plugs, various different components from our product range can be connected to the M 30 x 35 thread

### Modular Concept

- The „satellite“ module is extendible with additional features, e.g. level controls, funnels, lab stirrers or...

### Convertible

- Thanks to the exhaust filter blind plug, the "Waste Cap" (disposal) be converted into a "Safety Cap" (supply)
- The air valve fits into the capillary connection

### PP Tube Connectors

- Connections for larger tubes, having an inner diameter of 5.0 - 11.5 mm. Within the scope of delivery of LISA: 3 tube connectors, with an NPT 1/8" thread.

### Satellite made of PTFE

- Our satellite is made of (pure) PTFE, for optimal chemical resistance
- The cap can be rotated through 360°, in order to allow for simple exchange of the container, without any resultant twisting of tubing

### PFA Fittings

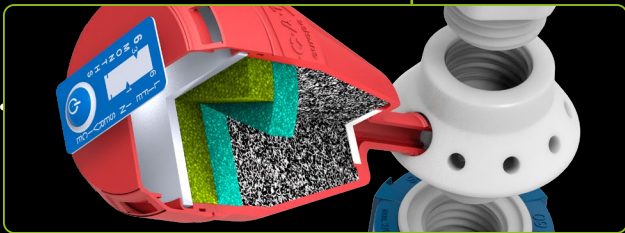
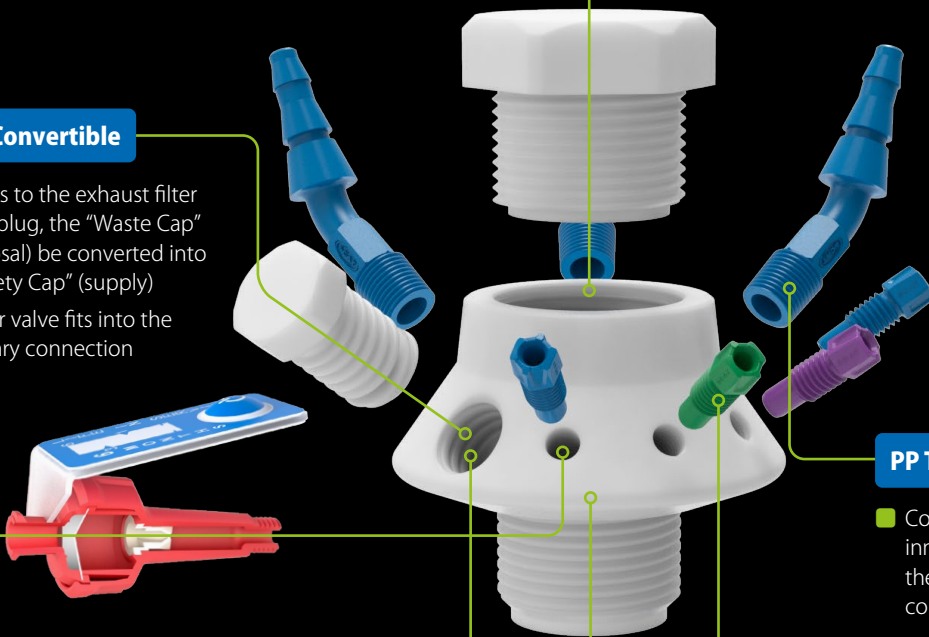
- Improved design, for even easier connection of capillaries. Excellent chemical resistance. Flammability Classification V-0, as per UL-94.
- Has standard connections for HPLC capillaries of outer diameter 1.6 mm, 2.3 mm or 3.2 mm. The scope of delivery of the LISA includes 12 fittings with a UNF 1/4" thread.

### Screw Cap made of PPS (GL 45 & S 60)

- Suitable for various collecting containers
- Simple installation and easy exchange
- Autoclavable / sterilizable, up to 200°C, Flammability Classification V-0, as per UL-94
- Stable Construction
- Improved handling

### GL 14 Connection for Exhaust Filter

- The Safety Waste Cap LISA has a connection for all exhaust filters from our product range. With the aid of optimized active carbon, SCAT exhaust filters block harmful vapours, thereby ensuring for safe pressure equalization in the waste containers of your HPLC systems.



HPLC-Supply

HPLC-Disposal

Safety Funnels

Level Control

Containers

Accessory

Addendum

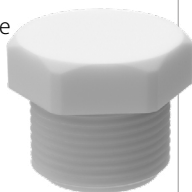


## Safety Waste Cap LISA

### Scope of Delivery **A**

#### Blind plug satellite LISA

■ PTFE, white



1x

#### Safety Waste Cap LISA satellite with screw cap

■ PTFE, white



1x

#### Blind plug for exhaust filter connection

■ PTFE, white



1x

#### Tube connector, stepped, curved

■ Ø 5 - 11.5 mm OD

■ PP, blue



3x

#### Blind plug for tube connection

■ PTFE, white



3x

#### Fitting for capillaries

■ Ø 1.6 mm ID

■ PFA, green



4x

#### Fitting for capillaries

■ Ø 2.2 mm ID

■ PFA, violet



4x

#### Fitting for capillaries

■ Ø 3.2 mm ID

■ PFA, blue



4x

#### Blind plug for capillary connection

■ PFA, colourless



4x



Also available as electrostatic conductive version.

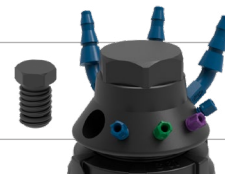


Fig.	Part No.	Description	Thread	Capillary Connections	Tube Connections	Blind Plugs	Exhaust Filter Connection	Electrostatic conductive
<b>A</b>	<b>350 045</b>	Safety Waste Cap LISA	GL 45	4x	3x	9x	●	-
	<b>450 045</b>	Safety Waste Cap LISA	GL 45	4x	3x	9x	●	●
	<b>350 050</b>	Safety Waste Cap LISA	S 50	4x	3x	9x	●	-
	<b>450 050</b>	Safety Waste Cap LISA	S 50	4x	3x	9x	●	●
	<b>350 051</b>	Safety Waste Cap LISA	S 51	4x	3x	9x	●	-
	<b>350 053</b>	Safety Waste Cap LISA	B 53	4x	3x	9x	●	-
	<b>350 055</b>	Safety Waste Cap LISA	S 55	4x	3x	9x	●	-
	<b>350 060</b>	Safety Waste Cap LISA	S 60/61	4x	3x	9x	●	-
	<b>450 060</b>	Safety Waste Cap LISA	S 60/61	4x	3x	9x	●	●
	<b>350 063</b>	Safety Waste Cap LISA	B 63	4x	3x	9x	●	-
	<b>350 065</b>	Safety Waste Cap LISA	S 65	4x	3x	9x	●	-
	<b>350 070</b>	Safety Waste Cap LISA	S 70/71	4x	3x	9x	●	-
	<b>350 083</b>	Safety Waste Cap LISA	B 83	4x	3x	9x	●	-
	<b>350 090</b>	Safety Waste Cap LISA	S 90	4x	3x	9x	●	-
	<b>350 095</b>	Safety Waste Cap LISA	S 95	4x	3x	9x	●	-

# Safety Waste Cap LISA Extensions and Accessories

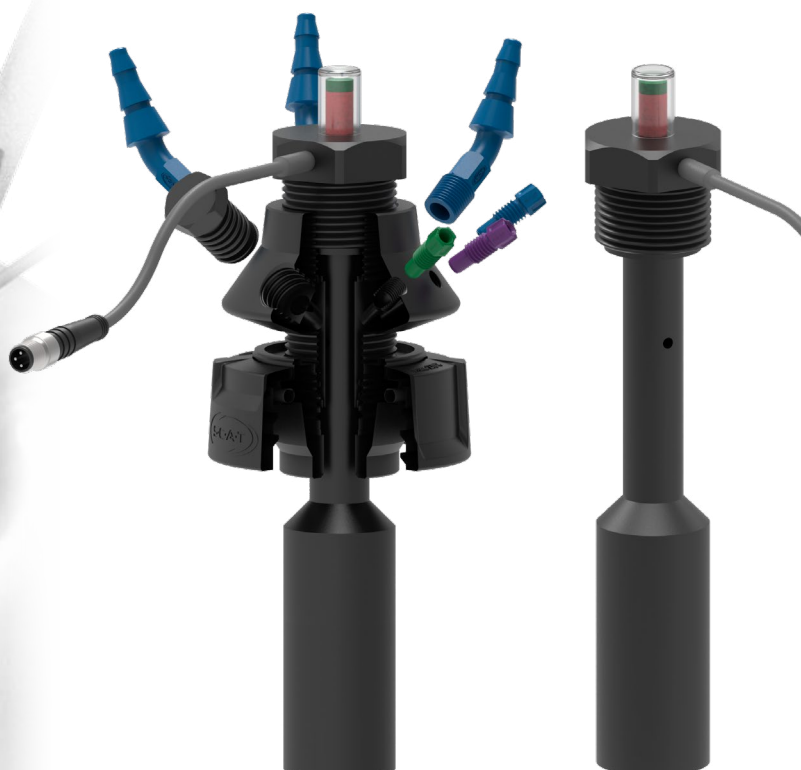
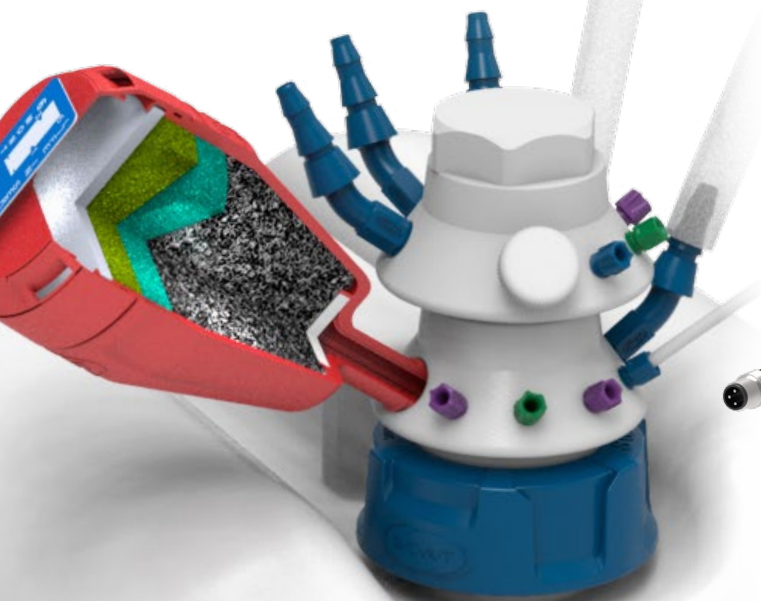
## Expandable

- The modular concept of LISA makes it easy to expand the number of connections. Extensions and accessories can be found on the next page.



## Modular Concept

- The "satellite" module is extendible with additional features, e.g. funnels, level control and tube adapters



HPLC-Supply

HPLC-Disposal

Safety Funnels

Level Control

Containers

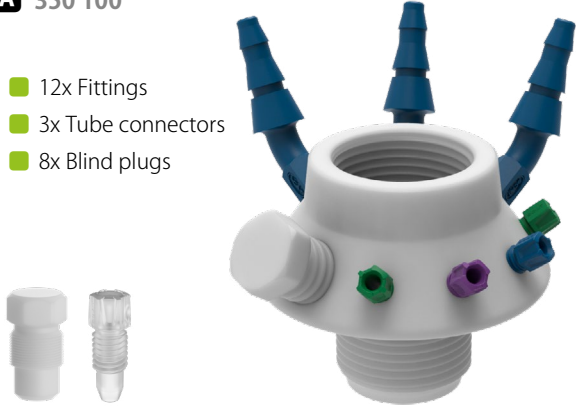
Accessory

Addendum

## Safety Waste Cap LISA Extensions and Accessories

**A** 350 100

- 12x Fittings
- 3x Tube connectors
- 8x Blind plugs

**C** 350 120**E** 350 121**B** 450 100

- 12x Fittings
- 3x Tube connectors
- 8x Blind plugs

**D** 450 120**F** 450 121**G** 350 110**H** 450 110**I** 410 534**J** 410 535**K** 407 986**L** 117 808

Fig.	Art. Nr.	Description	Thread	Electrostatic conductive	Unit
<b>A</b>	<b>350 100</b>	Extension satellite LISA, PTFE	M 30 x 35	-	1
<b>B</b>	<b>450 100</b>	Extension satellite LISA, PTFE-EL	M 30 x 35	●	1

## Safety Waste Cap LISA Extensions and Accessories



Fig.	Fig.	Description	Thread	Electrostatic conductive	Unit
<b>C</b>	350 120	Funnel with lid MARCO for LISA, PE-HD, removable sieve	M 30 x 35	-	1
<b>D</b>	450 120	Funnel with lid MARCO for LISA, PE-HD-EL, removable sieve	M 30 x 35	●	1
<b>E</b>	350 121	Level Control for LISA	M 30 x 35	-	1
<b>F</b>	450 121	Level Control for LISA	M 30 x 35	●	1
<b>G</b>	350 110	Blind plug satellite LISA, PTFE	M 30 x 35	-	1
<b>H</b>	450 110	Blind plug satellite LISA, PTFE-EL	M 30 x 35	●	1
<b>I</b>	410 534	Exhaust filter S, V3.0, with change indicator	GL 14	-	1
	490 335	Reserve pack exhaust filter S, V3.0, with change indicator	GL 14	-	4
<b>J</b>	410 535	Exhaust filter M, V3.0, with change indicator	GL 14	-	1
	490 336	Reserve pack exhaust filter M, V3.0, with change indicator	GL 14	-	2
<b>K</b>	407 986	Exhaust filter L, V3.0, with change indicator	GL 14	-	1
	490 986	Reserve pack exhaust filter L, V3.0, with change indicator	GL 14	-	2
<b>L</b>	117 808	Tube connector, stepped, curved, 5.0 - 11.5 mm OD	NPT 1/8"	-	1
<b>M</b>	160 506	Blind plug for tube connection, PTFE	NPT 1/8"	-	1
<b>N</b>	160 523	Blind plug for tube connection, PTFE-EL	NPT 1/8"	●	1
<b>O</b>	107 620	Blind plug, PTFE, for exhaust filter connection	GL 14	-	1
<b>P</b>	107 680	Blind plug, PTFE-EL, for exhaust filter connection	GL 14	●	1
<b>Q</b>	107 061	PFA Fitting with integrated ferrule, 1.6 mm ID, green	UNF 1/4"	-	5
<b>R</b>	107 059	PFA Fitting with integrated ferrule, 2.3 mm ID, violet	UNF 1/4"	-	5
<b>S</b>	107 063	PFA Fitting with integrated ferrule, 3.2 mm ID, blue	UNF 1/4"	-	5
<b>T</b>	160 502	Blind plug for capillary connection, PFA, colourless	UNF 1/4"	-	5
	160 501	Blind plug for capillary connection, PFA, colourless	UNF 1/4"	-	10



# JAN Universal Waste Hub

The clever all-rounder for liquid waste disposal.





## JAN Benefits

### ✓ The Universal Solution for Liquid Waste!

The new Universal Waste Hub JAN is not only equipped to deal with solvent waste from HPLC units, it is also able to handle other waste liquids, both safely and without smelling.

### ✓ State-of -the-Art Safety and Environmental Protection

The integrated exhaust filter prevents the exit of damaging vapours and ensures for a safe pressure equalization within the container. With Fire Protection V-0 as per UL 94!

### ✓ The All-in-One Solution for Liquid Waste in the Laboratory!

A complete spectrum of supply (24 components) is always available, for all eventualities and all connection possibilities.

### ✓ DIN- / ISO- / ASTM-tested Material

The materials used are tested per official DIN/ISO/ASTM Standards, for optimum durability and safety, also w.r.t. aggressive chemicals.



#### JAN = LISA with MARCO and exhaust filter.

The Universal Waste Hub JAN uses the "satellite" based on the Safety Waste Cap LISA and is standardly equipped with safety funnel MARCO and including an exhaust filter.

## Universal Waste Hub JAN Technical Details



# Universal Waste Hub JAN Technical Details



### Stable Hinge

- Double-screw hinge made of rust-free stainless steel: for high durability and stability

### Fire Protection (V-0)

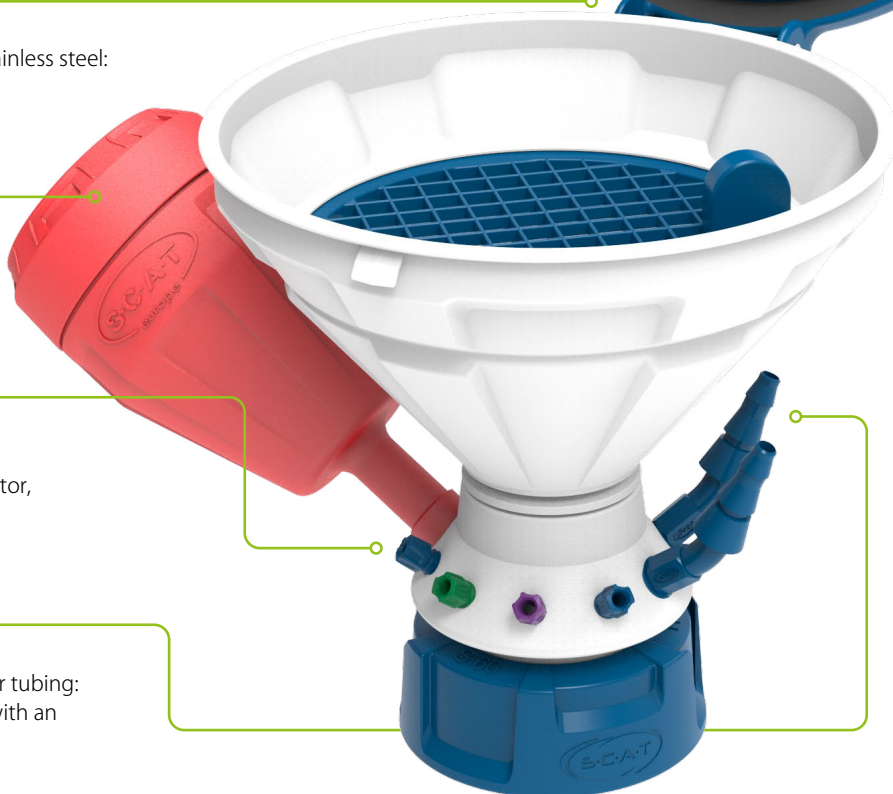
- Filter housing constructed of partially crystalline PP, certified according to Fire Protection Class V-0 as per UL-94

### 4 HPLC Connections (PFA)

- Always fits: fittings for capillaries of sizes 1.6, 2.3 and 3.2 mm, and for every connector, are within the scope of delivery

### 3 Tube Connectors (PP)

- For more flexibility when connecting your tubing: the tube connector is suitable for tubes with an inner diameter of 5 to 11.5 mm



### Accessories supplied!

Fittings, tube connectors and blind plugs are included in every size.

ID 1.6 mm 2.3 mm 3.2 mm -





## Universal Waste Hub JAN Standard: Fully-Equipped (25 Parts)



### Universal Waste Hub JAN

- S 60/61 Thread
- 4 HPLC connections
- 3 Tube connections
- 1 Connection for exhaust filter
- Safety funnel
- Removable sieve
- With lid



1x

#### Fitting for capillaries

- Ø 1.6 mm ID
- PFA, green



4x

#### Fitting for capillaries

- Ø 2.3 mm ID
- PFA, violet



4x

#### Fitting for capillaries

- Ø 3.2 mm ID
- PFA, blue



4x

#### Blind plug for capillary connection

- PFA, colourless



4x

#### Tube connector, stepped, curved

- Ø 5 - 11.5 mm OD
- PP, blue



3x

#### Blind plug for tube connection

- PTFE, white



3x

#### Exhaust filter

- Size M
- Lifetime: 6 month



1x

#### Blind plug for exhaust filter connection

- PTFE, white



1x

Fig.	Part No.	Description	Contents		
A	320 060	Universal Waste Hub JAN	<b>Quantity</b>	<b>Description</b>	<b>See also</b>
			1x	Universal Waste Hub JAN	► Page 98
			4x	PFA Fitting, 1.6 mm ID, green	► Page 156
			4x	PFA Fitting, 2.3 mm ID, violet	► Page 156
			4x	PFA Fitting, 3.2 mm ID, blue	► Page 156
			4x	Blind plug for capillary connection, PFA, colourless	► Page 156
			3x	Tube connector, stepped, curved, Ø 5 - 11.5 mm OD	► Page 158
			3x	Blind plug for tube connection, PTFE, white	► Page 159
			1x	Exhaust filter M, V3.0, with splash protection and change indicator	► Page 71
1x	Blind plug for exhaust filter connection, PTFE, white	► Page 154			

## Universal Waste Hub JAN Ordering Information

**A** 320 060



**B** 420 060



### Information about “delivery with adapter”:

The Universal Waste Hub JAN is available for various container threads. In order to manufacture, both ecologically and economically, we can deliver some variants together with a thread adapter.



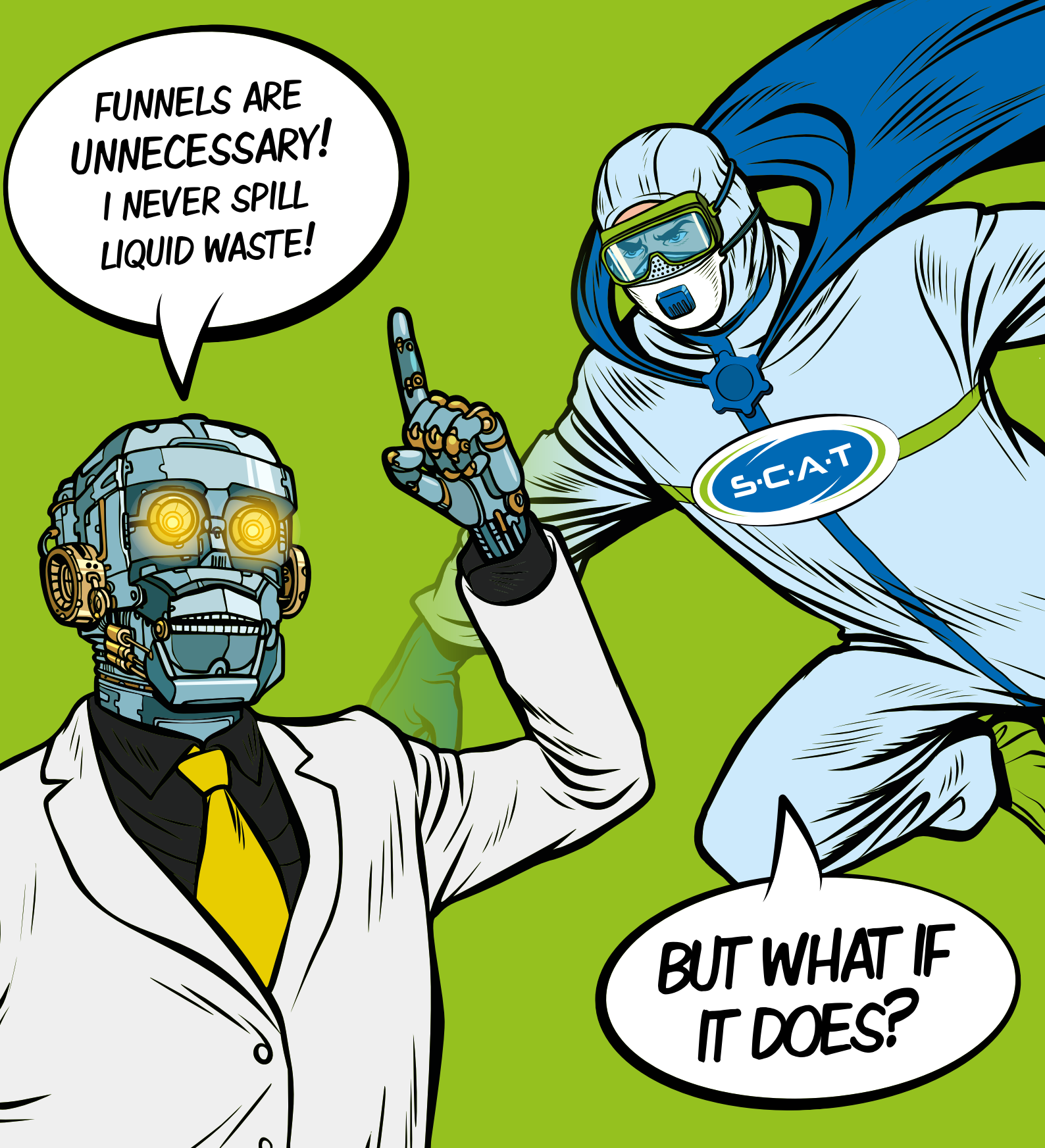
### Electrostatic conductive

Models in black are made of electrostatic conductive PE-HD and are additionally supplied with a grounding cable and clamp.



Fig.	Part No.	Description	Thread	Electrostatic conductive	Delivery with Adapter
	320 045	Universal Waste Hub JAN	GL 45	-	-
	420 045	Universal Waste Hub JAN	GL 45	●	-
	320 050	Universal Waste Hub JAN	S 50	-	●
	320 051	Universal Waste Hub JAN	S 51	-	●
	320 053	Universal Waste Hub JAN	B 53	-	●
	320 055	Universal Waste Hub JAN	S 55	-	-
<b>A</b>	320 060	Universal Waste Hub JAN	S 60/61	-	-
<b>B</b>	420 060	Universal Waste Hub JAN	S 60/61	●	-
	320 063	Universal Waste Hub JAN	B 63	-	●
	320 065	Universal Waste Hub JAN	S 65	-	●
	320 070	Universal Waste Hub JAN	S 70/71	-	●
	320 083	Universal Waste Hub JAN	B 83	-	●
	320 090	Universal Waste Hub JAN	S 90	-	●
	320 095	Universal Waste Hub JAN	S 95	-	●





## **Optimum Protection when collecting Liquid Waste.**

[www.scatt-europe.com](http://www.scatt-europe.com)

In the hectic daily routine of a laboratory, things can easily go wrong. Open containers become a danger to people and the environment. Anyone who wants to get their waste disposal under control therefore needs a coherent concept. Our safety funnels are a one-time investment for many years of health and safety.

# Safety Funnels

- ✓ Collect Liquid Waste Safely
- ✓ High-Quality Materials
- ✓ Robust and Durable
- ✓ Suitable for Organic Solvents



# Harmful Liquids Ever Spilled?

Open containers quickly create fire and health hazards. SCAT safety funnels can be safely closed and prevent ignition hazards. Also available in electrostatic conductive plastic!





## You know This? Comparison



Canister without funnel. The contents steam out and are not protected against overflowing. Spills are inevitable.



Double safety due to hinged lid and ball-valve.



# MARCO

## Safety Funnel with Hinged Lid

Smart protection when collecting liquid waste!





# Safety Funnel MARCO Technical Details



### Safe Closure

- Comfortable handling: easy, quick opening and closing with "click"-closure

### Hinged Lid with Sealing Ring

- For secure closure, when the funnel is not in use

### Stable Hinge

- A double-screw hinge, constructed of rust-free stainless steel: for long life and stability

140 mm

### Dirt Sieve

- For collecting mixing magnets or large dirt particles. Laboratory bottles can also be placed here to dry off. The hole size has been optimized, in order to improve the running-off of chemicals. **Both sieve and splash protection can be removed for cleaning.**



### Too coarse-meshed?

- Optionally available: Fine-mesh stainless steel sieve

### Various Screw-Threads

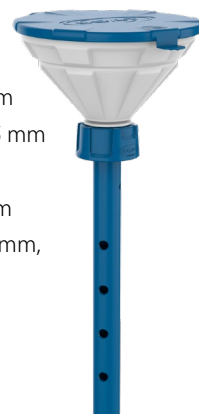
- Suitable for different sizes of collecting canister

### Safety Lance

- Ensures for safe and good flowing of sensitive chemicals, without any "stuttering"

### Dimensions:

- Height with lance: 345 mm
- Height without lance: 125 mm
- Max. width: 185 mm
- Inner diameter: Ø 140 mm
- Installation height: + 105 mm, with vertically opened lid: + 270 mm



HPLC-Supply

HPLC-Disposal

Safety Funnels

Level Control

Containers

Accessory

Addendum

## Safety Funnel MARCO Ordering Information

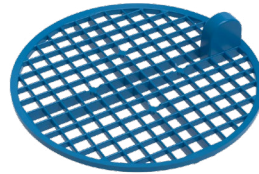
**A** 318 952



**B** 318 992



**F** 318 999



**G** 318 998



**H** 319 000



**Too coarse-meshed?**

- Optionally available: Fine-mesh stainless steel sieve

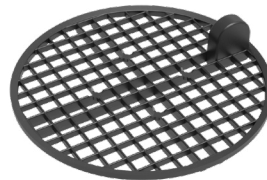
**C** 318 960



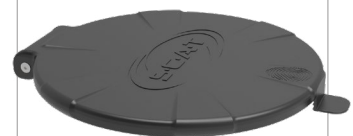
**D** 318 980



**I** 318 989



**J** 318 988



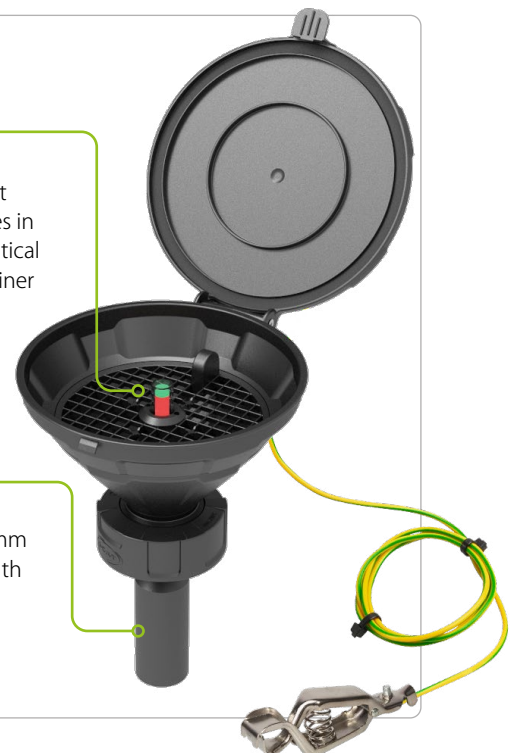
**E** 317 637

**Level Control**

- Protection against overflow. Indicates in time when the critical level of the container has reached.

**Floater**

- Available in 150 mm and 190 mm length



**Might interest you**

When our lid funnel MARCO is combined with the LISA, this combination goes by the name of JAN, see **page 94**.



## Safety Funnel MARCO

### Ordering Information



**K** 318 994



#### Informations about "delivery with adapter":

The safety funnel MARCO is available in various container screw-thread sizes. In order that we may produce in an environmentally-friendly and economic manner, certain variants are delivered together with a screw-thread adapter. Those to which this applies can be seen in the column "Delivery with Adapter".

Fig.	Part No.	Description	Screw-Thread of Container	Lance (220 mm)	Electrostatic conductive	Material	Level Control	Delivery with Adapter
<b>A</b>	318 952	Hinged lid Funnel MARCO	GL 45	-	-	PE-HD	-	-
	318 962	Hinged lid Funnel MARCO	GL 45	-	●	PE-HD-EL	-	-
<b>B</b>	318 992	Hinged lid Funnel MARCO	GL 45	●	-	PE-HD	-	-
	318 955	Hinged lid Funnel MARCO	S 50	-	-	PE-HD	-	●
	318 985	Hinged lid Funnel MARCO	S 50	●	●	PE-HD-EL	-	●
	318 995	Hinged lid Funnel MARCO	S 50	●	-	PE-HD	-	●
	318 953	Hinged lid Funnel MARCO	S 51	-	-	PE-HD	-	●
	318 983	Hinged lid Funnel MARCO	S 51	●	●	PE-HD-EL	-	●
	318 993	Hinged lid Funnel MARCO	S 51	●	-	PE-HD	-	●
	318 951	Hinged lid Funnel MARCO	S 55	-	-	PE-HD	-	-
	318 961	Hinged lid Funnel MARCO	S 55	-	●	PE-HD-EL	-	-
	318 981	Hinged lid Funnel MARCO	S 55	●	●	PE-HD-EL	-	-
	318 991	Hinged lid Funnel MARCO	S 55	●	-	PE-HD	-	-
	318 950	Hinged lid Funnel MARCO	S 60/61	-	-	PE-HD	-	-
<b>C</b>	318 960	Hinged lid Funnel MARCO	S 60/61	-	●	PE-HD-EL	-	-
<b>D</b>	318 980	Hinged lid Funnel MARCO	S 60/61	●	●	PE-HD-EL	-	-
	318 990	Hinged lid Funnel MARCO	S 60/61	●	-	PE-HD	-	-
<b>E</b>	317 637	Hinged lid Funnel MARCO	S 60/61	-	●	PE-HD-EL	● 150 mm	-
	317 651	Hinged lid Funnel MARCO	S 60/61	-	●	PE-HD-EL	● 190 mm	-
	318 954	Hinged lid Funnel MARCO	S 65	-	-	PE-HD	-	●
	318 964	Hinged lid Funnel MARCO	S 65	-	●	PE-HD-EL	-	●
	318 984	Hinged lid Funnel MARCO	S 65	●	●	PE-HD-EL	-	●
<b>K</b>	318 994	Hinged lid Funnel MARCO	S 65	●	-	PE-HD	-	●
<b>F</b>	318 999	Dirt sieve for hinged lid MARCO, PE-HD, blue						
<b>G</b>	318 998	Replacement lid for hinged lid funnel MARCO, PE-HD, blue						
<b>H</b>	319 000	Dirt sieve for hinged lid MARCO, stainless steel, 105 mm, fine-mesh						
<b>I</b>	318 989	Dirt sieve for hinged lid MARCO, PE-HD-EL, black						
<b>J</b>	318 988	Replacement lid for hinged lid funnel MARCO, PE-HD-EL, black						

# Safety Funnel MARCO Disposal-Sets

Collect liquid HPLC waste safely: Sets including container and funnel, ready for immediate use - without time-consuming assembling of a configuration.

START  
IMMEDIATELY  
WITHOUT  
HESITATION!



## Even more selection

Further disposal sets, including electrostatic conductive versions, can be found in the "funnel sets" section of our website: [www.scat-europe.com](http://www.scat-europe.com)

Scan the **QR code** to go directly to the funnel sets section of our website.





## Safety Funnel MARCO Disposal-Sets

**A** 307 316

### Hinged lid funnel MARCO

- GL 45 Thread
- Removable sieve
- PE-HD



### Waste canister

- GL 45 Thread
- 2,5 Litre
- PE-HD

Fig.	Part No.	Description	Contents		
<b>A</b>	<b>307 316</b>	Funnel Disposal-Set	<b>Quantity</b>	<b>Description</b>	<b>See also</b>
			1x	Hinged lid funnel MARCO, GL 45, PE-HD, with removable sieve	▶ Page 106
			1x	2,5 Litre canister, GL 45, PE-HD	▶ Page 136
	<b>307 317</b>	Funnel Disposal-Set	<b>Quantity</b>	<b>Description</b>	<b>See also</b>
			1x	Hinged lid funnel MARCO, GL 45, PE-HD, with removable sieve	▶ Page 106
			1x	5 Litre canister, GL 45, PE-HD	▶ Page 136
	<b>307 318</b>	Funnel Disposal-Set	<b>Quantity</b>	<b>Description</b>	<b>See also</b>
			1x	Hinged lid funnel MARCO, GL 45, PE-HD, with removable sieve	▶ Page 106
			1x	10 Litre canister, GL 45, PE-HD	▶ Page 136

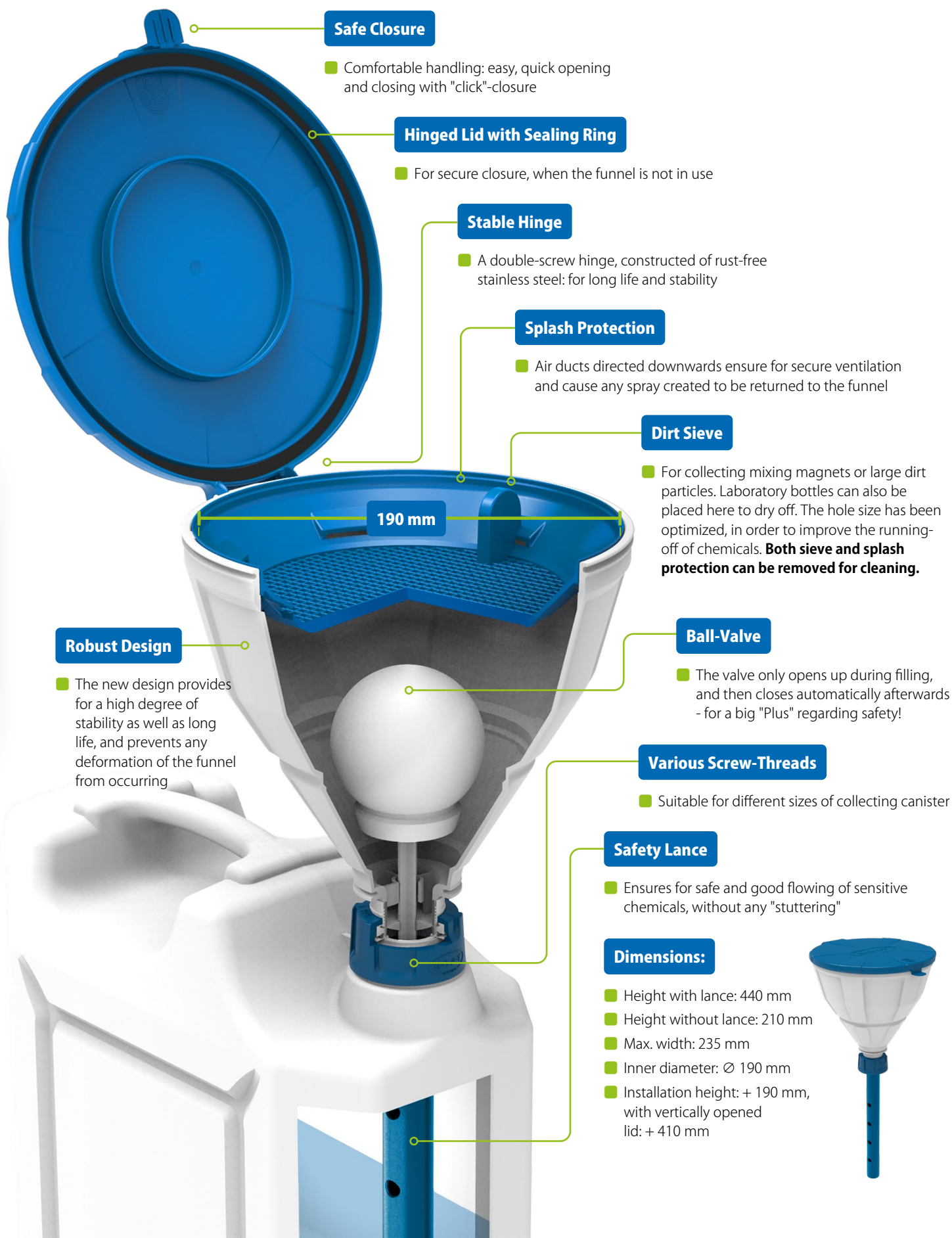


# ARNOLD Ball-Valve Funnel with Hinged Lid

Strong protection when collecting liquid waste!



## Safety Funnel ARNOLD Technical Details



### Safe Closure

- Comfortable handling: easy, quick opening and closing with "click"-closure

### Hinged Lid with Sealing Ring

- For secure closure, when the funnel is not in use

### Stable Hinge

- A double-screw hinge, constructed of rust-free stainless steel: for long life and stability

### Splash Protection

- Air ducts directed downwards ensure for secure ventilation and cause any spray created to be returned to the funnel

### Dirt Sieve

- For collecting mixing magnets or large dirt particles. Laboratory bottles can also be placed here to dry off. The hole size has been optimized, in order to improve the running-off of chemicals. **Both sieve and splash protection can be removed for cleaning.**

190 mm

### Robust Design

- The new design provides for a high degree of stability as well as long life, and prevents any deformation of the funnel from occurring

### Ball-Valve

- The valve only opens up during filling, and then closes automatically afterwards - for a big "Plus" regarding safety!

### Various Screw-Threads

- Suitable for different sizes of collecting canister

### Safety Lance

- Ensures for safe and good flowing of sensitive chemicals, without any "stuttering"

### Dimensions:

- Height with lance: 440 mm
- Height without lance: 210 mm
- Max. width: 235 mm
- Inner diameter:  $\varnothing$  190 mm
- Installation height: + 190 mm, with vertically opened lid: + 410 mm

## Safety Funnel ARNOLD Ordering Information

**A** 317 642



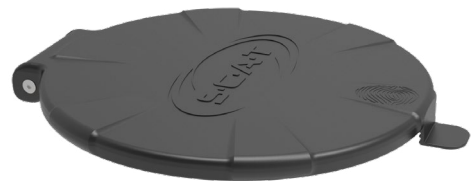
**B** 317 622



**D** 319 001



**F** 319 002



**E** 317 640



**G** 317 620



## Safety Funnel ARNOLD

### Ordering Information



#### Informations about "delivery with adapter":

The safety funnel ARNOLD is available in various container screw-thread sizes. In order that we may produce in an environmentally-friendly and economic manner, certain variants are delivered together with a screw-thread adapter. Those to which this applies can be seen in the column "delivery with adapter".

Fig.	Part No.	Description	Screw-Thread of Container	Lance (220 mm)	Electrostatic conductive	Material	Delivery with Adapter
<b>A</b>	<b>317 642</b>	Ball-valve funnel ARNOLD	<b>GL 45</b>	●	-	PE-HD	-
<b>B</b>	<b>317 622</b>	Ball-valve funnel ARNOLD	<b>GL 45</b>	●	●	PE-HD-EL	-
	<b>317 638</b>	Ball-valve funnel ARNOLD	<b>GL 45</b>	-	●	PE-HD-EL	-
	<b>317 649</b>	Ball-valve funnel ARNOLD	<b>S 50</b>	●	-	PE-HD	●
	<b>317 629</b>	Ball-valve funnel ARNOLD	<b>S 50</b>	●	●	PE-HD-EL	●
	<b>317 644</b>	Ball-valve funnel ARNOLD	<b>S 51</b>	●	-	PE-HD	●
	<b>317 624</b>	Ball-valve funnel ARNOLD	<b>S 51</b>	●	●	PE-HD-EL	●
	<b>317 632</b>	Ball-valve funnel ARNOLD	<b>B 53</b>	●	-	PE-HD	●
	<b>317 645</b>	Ball-valve funnel ARNOLD	<b>S 55</b>	●	-	PE-HD	-
	<b>317 625</b>	Ball-valve funnel ARNOLD	<b>S 55</b>	●	●	PE-HD-EL	-
	<b>317 641</b>	Ball-valve funnel ARNOLD	<b>S 60/61</b>	●	-	PE-HD	-
	<b>317 621</b>	Ball-valve funnel ARNOLD	<b>S 60/61</b>	●	●	PE-HD-EL	-
	<b>317 646</b>	Ball-valve funnel ARNOLD	<b>S 65</b>	●	-	PE-HD	●
	<b>317 626</b>	Ball-valve funnel ARNOLD	<b>S 65</b>	●	●	PE-HD-EL	●
	<b>317 648</b>	Ball-valve funnel ARNOLD	<b>S 70/71</b>	●	-	PE-HD	●
	<b>317 628</b>	Ball-valve funnel ARNOLD	<b>S 70/71</b>	●	●	PE-HD-EL	●
	<b>317 647</b>	Ball-valve funnel ARNOLD	<b>B 83</b>	●	-	PE-HD	●
	<b>317 627</b>	Ball-valve funnel ARNOLD	<b>B 83</b>	●	●	PE-HD-EL	●
	<b>317 643</b>	Ball-valve funnel ARNOLD	<b>S 90</b>	●	-	PE-HD	●
	<b>317 623</b>	Ball-valve funnel ARNOLD	<b>S 90</b>	●	●	PE-HD-EL	●
<b>C</b>	<b>317 635</b>	Ball-valve funnel ARNOLD	<b>S 95</b>	●	●	PE-HD-EL	●
	<b>317 630</b>	Ball-valve funnel ARNOLD	<b>Double thread R2" BSP/G2" + 2" TriSure</b>	-	●	PE-HD-EL	-
<b>D</b>	<b>319 001</b>	Replacement lid for ball-valve funnel ARNOLD, PE-HD, blue					
<b>E</b>	<b>317 640</b>	Replacement sieve incl. splash protection for ball-valve funnel ARNOLD, PE-HD, blue					
<b>F</b>	<b>319 002</b>	Replacement lid for ball-valve funnel ARNOLD, PE-HD-EL, black					
<b>G</b>	<b>317 620</b>	Replacement sieve incl. splash protection for ball-valve funnel ARNOLD, PE-HD-EL, black					



# Safety Funnel ARNOLD Disposal-Set

Collect liquid HPLC waste safely: Sets including container and funnel, ready for immediate use - without time-consuming assembling of a configuration.

START  
IMMEDIATELY  
WITHOUT  
HESITATION!



## Even more selection

Further disposal sets, including electrostatic conductive versions, can be found in the "funnel sets" section of our website: [www.scat-europe.com](http://www.scat-europe.com)

Scan the **QR code** to go directly to the funnel sets section of our website.





## Safety Funnel ARNOLD Disposal-Set

**A** 307 450



**Ball-valve funnel ARNOLD**

- S 55 Thread
- Removable sieve
- PE-HD

**Waste canister**

- S 55 Thread
- 10 Litre
- PE-HD

Fig.	Part No.	Description	Contents		
<b>A</b>	307 450	Funnel Disposal-Set	<b>Quantity</b>	<b>Description</b>	<b>See also</b>
			1x	Safety Funnel with ball-valve ARNOLD, S 55, PE-HD, sieve & splash protection	► Page 113
			1x	10 Litre canister S 55, PE-HD	► Page 137

HPLC-Supply

HPLC-Disposal

Safety Funnels

Level Control

Containers

Accessory

Addendum

# Funnel ARNOLD for Barrels

Double thread R2" BSP/G2" (m) + BCS 56x4 (m)

## Version without Ball-Valve

- ARNOLD funnels without ball valve are adapted for high flow rates or highly viscous liquids
- Equipped with an additional, removable dirt sieve (instead of ball-valve)

**A** 317 631



## Double Thread

- R2" BSP/G2" (m) + BCS 56x4 (m)



Fig.	Part No.	Description	Material
<b>A</b>	<b>317 631</b>	Barrel-Funnel ARNOLD with lid, double thread R2" BSP/G2" (m) + BCS 56x4 (m), with splash protection, removable sieve and grounding cable, 2 sieves	PE-HD-EL
	<b>317 630</b>	Barrel-Funnel ARNOLD <b>with ball-valve</b> and lid, double thread R2" BSP/G2" (m) + BCS 56x4 (m), with splash protection, removable sieve and grounding cable	PE-HD-EL

# Funnel ARNOLD with Level Control

For safe filling of barrels and large containers

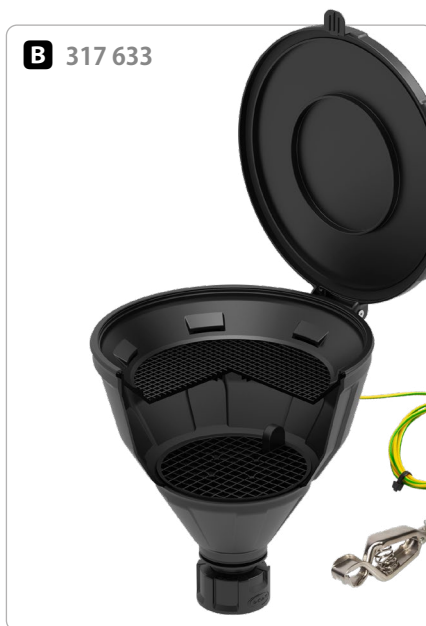


Fig.	Part No.	Description	Material
<b>A</b>	<b>317 636</b>	Funnel ARNOLD GL 45 with lid, 2 sieves	PE-HD
<b>B</b>	<b>317 633</b>	Funnel ARNOLD GL 45 with lid, 2 sieves	PE-HD-EL
<b>C</b>	<b>107 892</b>	Adapter for funnels with mechanical level control, barrel double thread R2" BSP/G2" (m) to GL 45 (m)	PP
<b>D</b>	<b>107 885</b>	Adapter for funnels with mechanical level control, barrel double thread R2" BSP/G2" (m) to GL 45 (m)	PE-HD-EL
	<b>317 660</b>	Set consisting of <b>A</b> and <b>C</b>	-
	<b>317 650</b>	Set consisting of <b>B</b> and <b>D</b>	-



**>>**  
**You might also be interested in**  
 Further adapters and mechanical level control on **page 129**.

- HP-L-Supply
- HP-L-Disposal
- Safety Funnels
- Level Control
- Containers
- Accessory
- Addendum



I'VE GOT THIS  
UNDER CONTROL

...OK SURE!  
I'M OFF THEN.

**Overflowing Containers -  
Harmful and Dangerous!  
The Solution: SCAT Europe  
Level Control Systems.**

SCAT level controls warn of overflowing or empty containers with a visual and acoustic signal. In addition, peripheral devices such as pumps and valves can be controlled via contact switches.

# Level Control

- ✓ Safe Monitoring of Fill and Empty Levels
- ✓ Electronic or Mechanical
- ✓ Manually Calibratable Alarms





# Level Control against Overflow and Emptiness

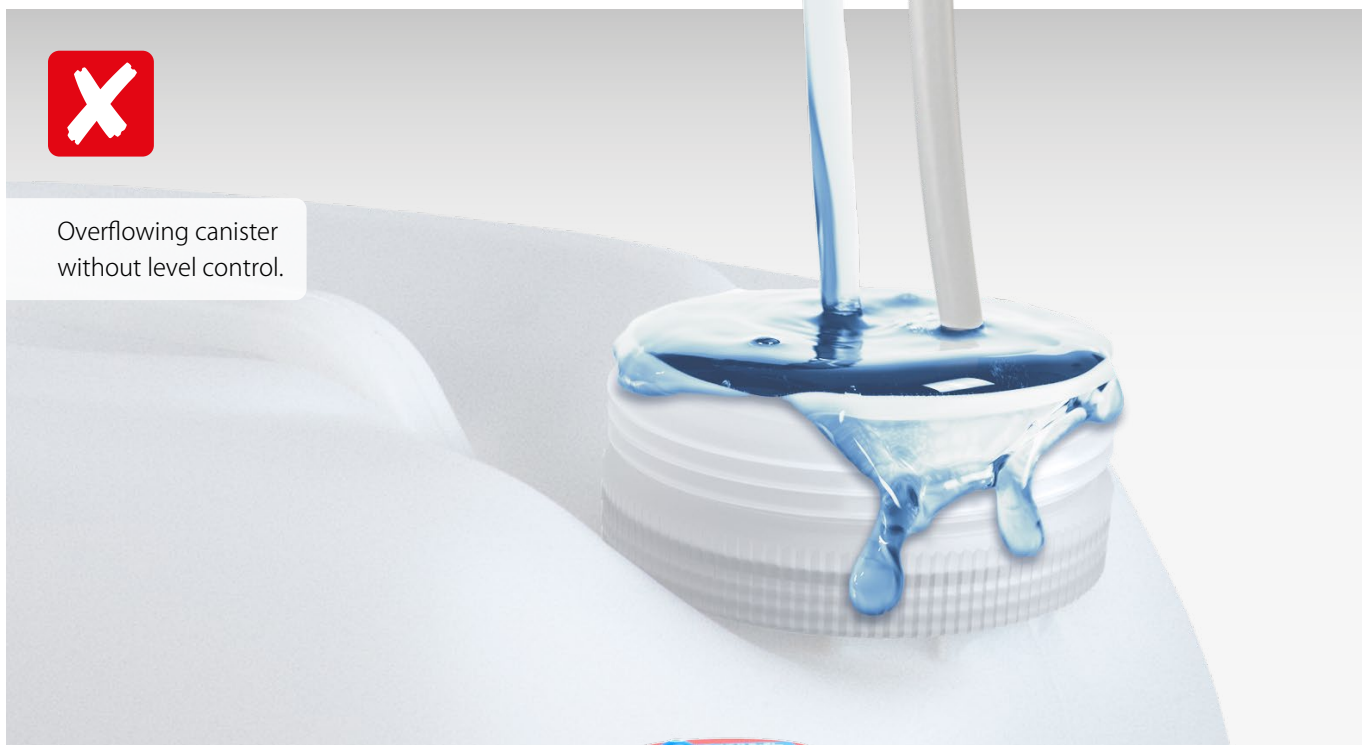
Whether overfilling or emptiness - both do harm and disrupt the processes in everyday laboratory work. The level control developed by SCAT warns of critical fill levels with an optical and acoustic signal. In addition, peripheral devices such as pumps and valves can be controlled via contact switches.



## You know This? Comparison



Overflowing canister  
without level control.



Hermetically sealed containers  
with fill or empty sensors.



# Sensors for Fill Level States

SCAT sensors detect liquids through glass or plastic, without contact with the contents of the container. Simply attach at the desired height - In conjunction with a SCAT signal box, you receive an optical and acoustic warning when a critical fill level is reached. Available as a fill level or empty level sensor.



## Fill or empty state

Sensors for fill and empty level state available.

## Easy Mounting

- Suitable for all commercially available containers made of glass or non-conductive plastic

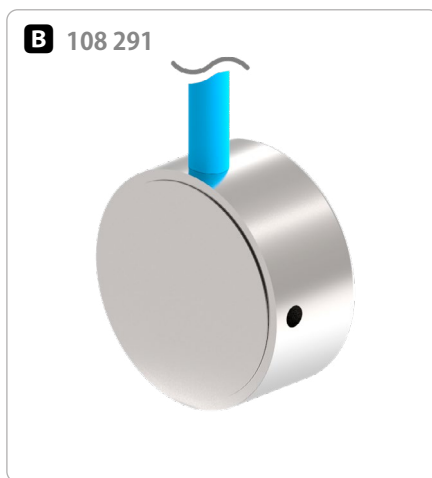
## Alarm

- Transmits signal to electronic signal boxes, see **page 124**

## Sensitivity

- The sensitivity is adjustable according to wall thickness

## Sensors for Fill Level States



**Looking for the right container?**

Canisters, bottles and other containers, suitable with the SCAT Level Control Sensors starting from **page 130**.



Fig.	Part No.	Description	Thread	Material	ATEX compliant
<b>A</b>	<b>108 048</b>	Disc sensor, alarm at full state	-	-	-
	<b>108 045</b>	Disc sensor, alarm at empty state	-	-	-
<b>B</b>	<b>108 291</b>	Capacitive disc sensor Output function: NAMUR, operating distance 1 - 10 mm adjustable Switch amplifier necessary (108 278)	-	Stainless steel Active: PTFE	●
<b>C</b>	<b>108 301</b>	Capacitive sensor for leakage control Output function: NAMUR, operating distance 0.5 - 3 mm adjustable Switch amplifier necessary (108 278)	-	PTFE	●
<b>D</b>	<b>108 277</b>	Capacitive rod sensor with LED indicator Sensor length: 70 mm, cable length: 2 m Output signal: NAMUR, operating distance 1 - 6 mm adjustable Switch amplifier necessary (108 278)	M12x1	PTFE	●
	<b>108 303</b>	Capacitive rod sensor with LED indicator Sensor length: 70 mm, cable length: 5 m Output signal: NAMUR, operating distance 1 - 6 mm adjustable Switch amplifier necessary (108 278)	M12x1	PTFE	●
<b>E</b>	<b>108 178</b>	Capacitive rod sensor for canister 108 042-S1 (page 144)	M18x1	Brass Active: PTFE	●
	<b>900 108</b>	Hook and loop fastener tape for disc sensor, length = 2 m	-	-	-
	<b>900 107</b>	Dual Lock, reclosable fastening system for disc sensor, 10 pieces	-	-	-

HPLC-Supply

HPLC-Disposal

Safety Funnels

Level Control

Containers

Accessory

Addendum

# Signal Boxes for Level Control

Our signal boxes always warn you in time with visual and acoustic signals before the determined fill level of your collection containers reaches the critical level. This prevents from unseen overflowing of your containers. Compatible with all SCAT level control sensors. The alarm can be silenced during the exchange of the container.

## Electronic Signal Boxes T1 and T5

- For disc sensors and Safety Waste Caps with electronic level control
- External devices such as pumps or valves can be controlled via potential-free outputs



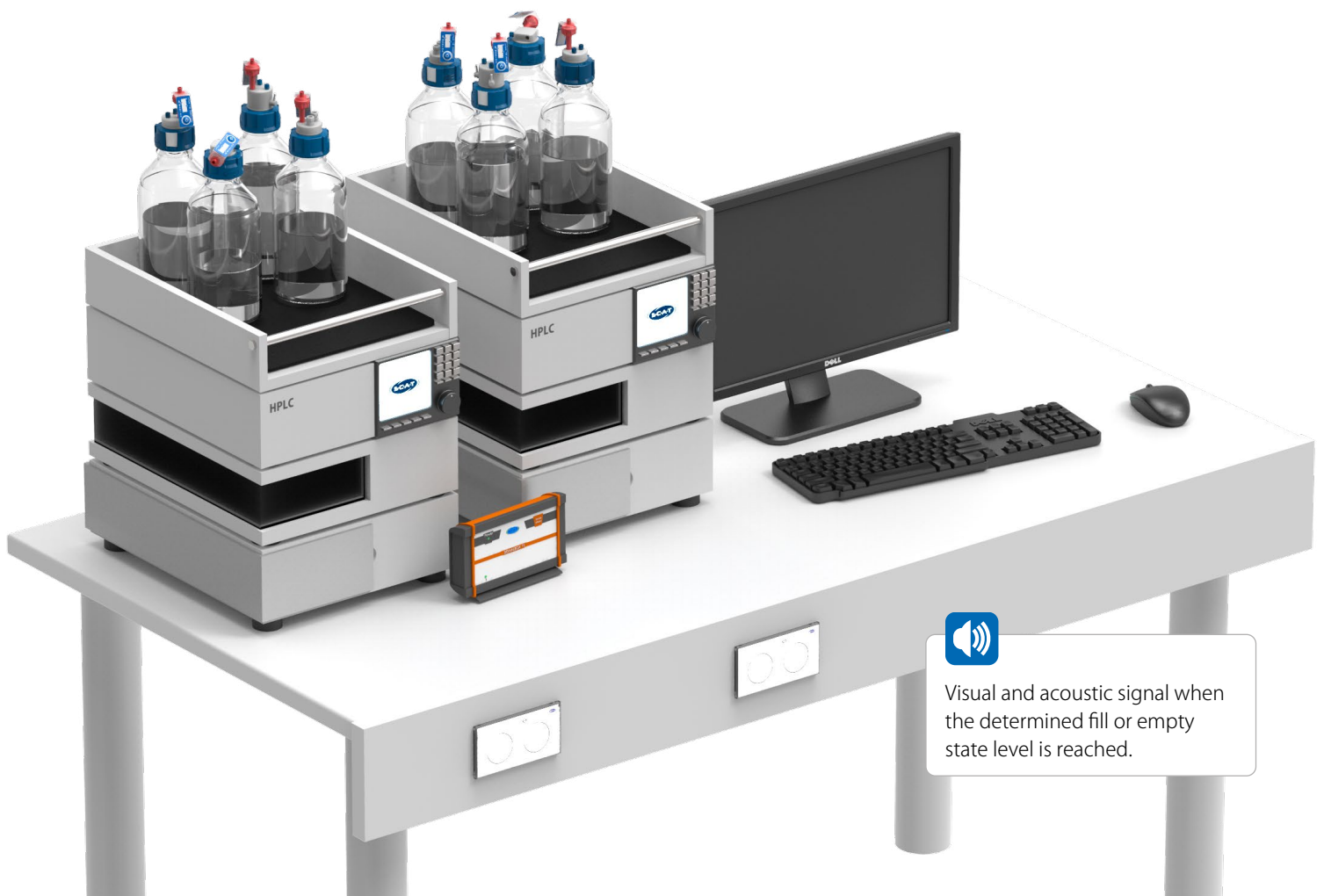
### Further informations

More informations about signal boxes can be found in our SymLine® system catalogue.

Visit our website [www.symline.de](http://www.symline.de) and go to the downloads section.

You can find an extract of the chapter "Level Control" with the following QR code.

**SymLine**<sup>®</sup>  
Chemical Waste Systems



Visual and acoustic signal when the determined fill or empty state level is reached.



# Signal Boxes for Level Control

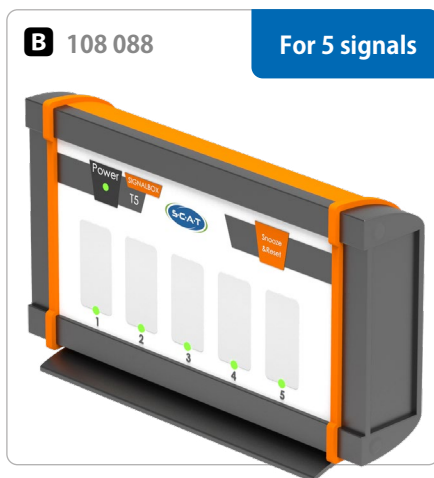
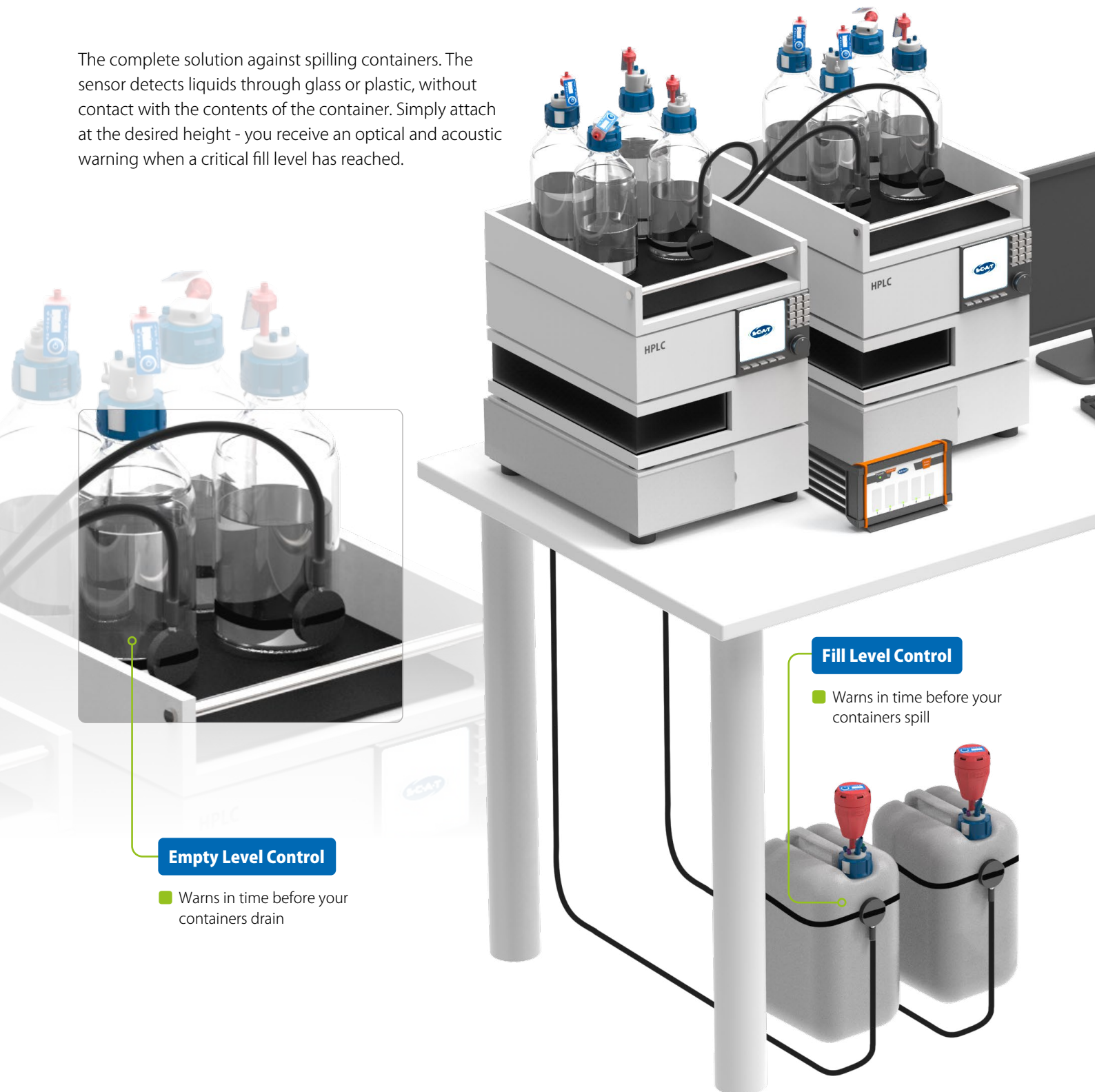


Fig.	Part No.	Description	Connections for Sensors	Material
<b>A</b>	108 087	Signalbox T1 (EU)	1	-
	108 122	Signalbox T1 (UK)	1	-
	108 119	Signalbox T1 (US)	1	-
<b>B</b>	108 088	Signalbox (EU)	5	-
	108 124	Signalbox T5 (UK)	5	-
	108 121	Signalbox T5 (US)	5	-
<b>C</b>	106 548	Built-in Signalbox² (EU)	2	-
	106 582	Built-in Signalbox² (UK)	2	-
	106 583	Built-in Signalbox² (US)	2	-
<b>D</b>	106 698	Table display for Built-in Signalbox², wall thickness: 2 mm	-	Stainless steel, brushed
<b>E</b>	106 658	Mount for Built-in Signalbox², wall thickness: 2 mm	-	Stainless steel, brushed
<b>F</b>	106 703	Front panel for Built-in Signalbox², wall thickness: 2 mm	-	Stainless steel, brushed
	108 304	Signal cable 1.5 m	-	-
	108 050	Signal cable 3 m	-	-
	108 037	Signal cable 5 m	-	-
	108 038	Signal cable 10 m	-	-

# Level Control Disc Sensor Sets

The complete solution against spilling containers. The sensor detects liquids through glass or plastic, without contact with the contents of the container. Simply attach at the desired height - you receive an optical and acoustic warning when a critical fill level has reached.



## Empty Level Control

- Warns in time before your containers drain

## Fill Level Control

- Warns in time before your containers spill

## Level Control Disc Sensor Sets



Fig.	Part No.	Description
<b>A</b>	<b>117 988</b>	Signalbox <b>T5</b> - <b>EU</b> , 5x disc sensor <b>fill state</b> , 5x 3 m signal cable, 5x 2 m hook and loop fastener for disc sensor incl. 220/230V EU power supply
	<b>108 125</b>	Signalbox <b>T1</b> - <b>EU</b> , with disc sensor, alarm at <b>fill state</b> , 3 m signal cable, 2 m hook and loop fastener for disc sensor, 220/230V EU power supply
	<b>108 157</b>	Signalbox <b>T1</b> - <b>EU</b> , with disc sensor, alarm at <b>empty state</b> , 3 m signal cable, 2 m hook and loop fastener for disc sensor, 220/230V EU power supply
	<b>108 158</b>	Signalbox <b>T1</b> - <b>USA</b> , with disc sensor, alarm at <b>fill state</b> , 3 m signal cable, 2 m hook and loop fastener for disc sensor, 110V USA power supply
	<b>108 159</b>	Signalbox <b>T1</b> - <b>USA</b> , with disc sensor, alarm at <b>empty state</b> , 3 m signal cable, 2 m hook and loop fastener for disc sensor, 110V USA power supply
	<b>108 160</b>	Signalbox <b>T1</b> - <b>UK</b> , with disc sensor, alarm at <b>fill state</b> , 3 m signal cable, 2 m hook and loop fastener for disc sensor, 220/230V UK power supply
	<b>108 161</b>	Signalbox <b>T1</b> - <b>UK</b> , with disc sensor, alarm at <b>empty state</b> , 3 m signal cable, 2 m hook and loop fastener for disc sensor, 220/230V UK power supply

# Level Control Mechanical

Reliable protection against spilling during the filling of barrels.



## Might interest you

SCAT Safety Waste Caps are also available with a mechanical level control.

More on this topic from **page 75**.



## Funnel for barrel

ARNOLD funnels without ball-valve are suitable for high flow rates or highly viscous liquids.

More on this topic from **page 110**.

## Adapter with Level Control for Funnel

- R2" BSP/G2" (m) to GL45 (m)

## Level Indicator for Barrels

- G3/4" (m)

## Level Control Mechanical



Fig.	Part No.	Description	Material	Thread	Electrostatic conductive
<b>A</b>	<b>107 883</b>	Level indicator, mechanical, for barrels, for containers up to 200 litre, Length of floater = 86 mm, diameter = 18 mm	PE-HD-EL	G3/4" (m)	●
<b>B</b>	<b>107 884</b>	Level indicator, mechanical, for barrels, for containers up to 200 litre, Length of floater = 150 mm, diameter = 18 mm	PTFE	G3/4" (m)	-
<b>C</b>	<b>107 885</b>	Adapter for funnels with mechanical level control, barrel double thread R2" BSP/G2" (m) to GL 45 (m)	PE-HD-EL	R2" BSP/G2" (m) to GL 45 (m)	●
<b>D</b>	<b>107 892</b>	Adapter for funnels with mechanical level control, barrel double thread R2" BSP/G2" (m) to GL 45 (m)	PP	R2" BSP/G2" (m) to GL 45 (m)	-
<b>E</b>	<b>107 886</b>	Adapter for funnels with mechanical level control, barrel thread BCS 70x6 (m) to GL 45 (m)	PE-HD-EL	R2" BSP/G2" (m) to GL 45 (m)	●
<b>F</b>	<b>107 889</b>	Adapter for funnels with mechanical level control, S 60 (f) to GL 45 (m)	PE-HD-EL	S 60 (f) to GL 45 (m)	●
<b>G</b>	<b>160 121</b>	Floater for mechanical / electronic level control, length 120 mm, PE-EL/PP	PE-HD-EL PE-HD	-	●
	<b>160 125</b>	Floater for mechanical / electronic level control, length 150 mm, PE-EL/PP	PE-HD-EL PE-HD	-	●
	<b>160 206</b>	Floater for mechanical / electronic level control, length 190 mm, PE-EL/PP	PE-HD-EL PE-HD	-	●
	<b>502 021</b>	Floater for mechanical / electronic level control, length 91.5 mm, PE-EL/PP	PE-HD-EL PE-HD	-	●

HPLC-Supply

HPLC-Disposal

Safety Funnels

Level Control

Containers

Accessory

Addendum



**WE DELIVER CONTAINERS. SAFE!**



## **Perfect Protection when Handling Liquids.**

From bottles made of break-proof glass, for safe extraction of solvents to supply the HPLC, to electrostatic conductive, 60 litre canisters with level control for disposal, SCAT offers a wide range of safety containers for all common requirements in your everyday laboratory work.

# Containers

Store and collect chemicals  
and liquid waste safely.



Scan the QR code and download a practical PDF  
overview of the laboratory glass range!



Scan the QR code and download a practical PDF  
overview of the canister range!

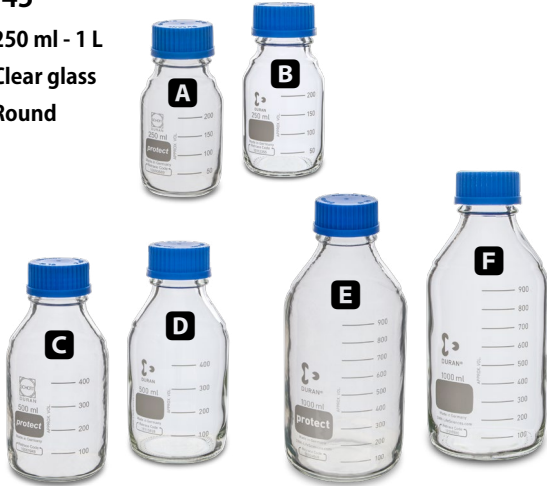


# Laboratory Glass Bottles Clear Glass



## GL 45

- 250 ml - 1 L
- Clear glass
- Round



**Clear Glass, Round**

- Storage capacity from 250 ml up to 10 L

**Break-Proof**

- Safe from glass breakage due to protective coating, see table

## GL 45

- 2 L - 10 L
- Clear glass
- Round



Fig.	Part No.	Description	Thread	Content	Glass Type	Form	Protective Coating
<b>A</b>	101 994	Laboratory bottle DURAN®, GL 45, 250 ml	GL 45	250 ml	Clear glass	Round	Yes
<b>B</b>	501 117	Laboratory bottle DURAN®, GL 45, 250 ml	GL 45	250 ml	Clear glass	Round	-
<b>C</b>	101 995	Laboratory bottle DURAN®, GL 45, 500 ml	GL 45	500 ml	Clear glass	Round	Yes
<b>D</b>	501 116	Laboratory bottle DURAN®, GL 45, 500 ml	GL 45	500 ml	Clear glass	Round	-
<b>E</b>	101 996	Laboratory bottle DURAN®, GL 45, 1 L	GL 45	1 Litre	Clear glass	Round	Yes
<b>F</b>	501 113	Laboratory bottle DURAN®, GL 45, 1 L	GL 45	1 Litre	Clear glass	Round	-
<b>G</b>	101 997	Laboratory bottle DURAN®, GL 45, 2 L	GL 45	2 Litre	Clear glass	Round	Yes
<b>H</b>	501 118	Laboratory bottle DURAN®, GL 45, 2 L	GL 45	2 Litre	Clear glass	Round	-
<b>I</b>	101 998	Laboratory bottle DURAN®, GL 45, 5 L	GL 45	5 Litre	Clear glass	Round	Yes
	501 125	Laboratory bottle DURAN®, GL 45, 5 L	GL 45	5 Litre	Clear glass	Round	-
<b>J</b>	501 126	Laboratory bottle DURAN®, GL 45, 10 L	GL 45	10 Litre	Clear glass	Round	-

# Laboratory Glass Bottles

## Clear Glass, Brown Glass

# GL 45, GL 28

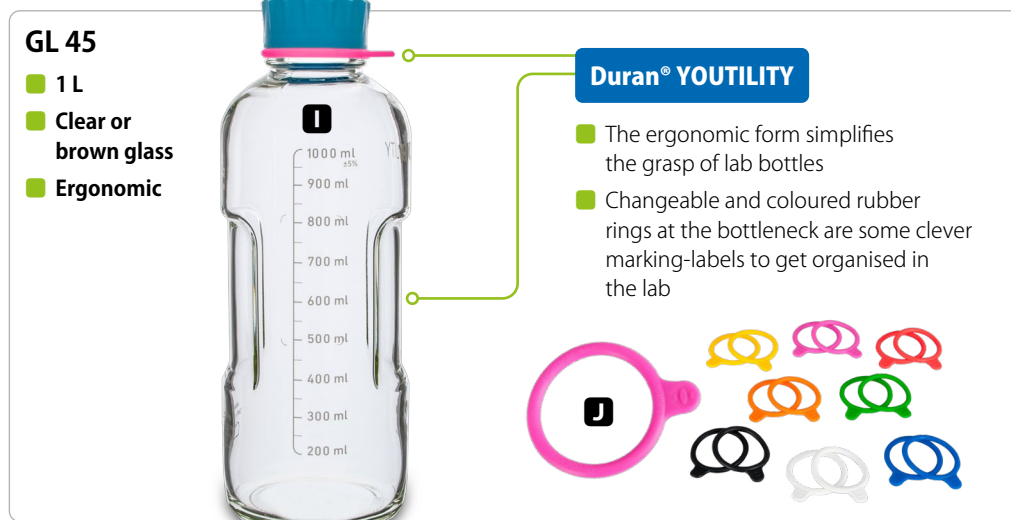
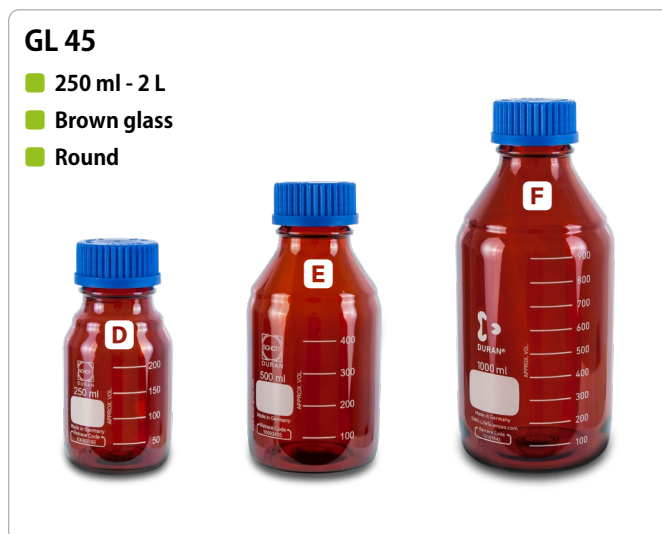
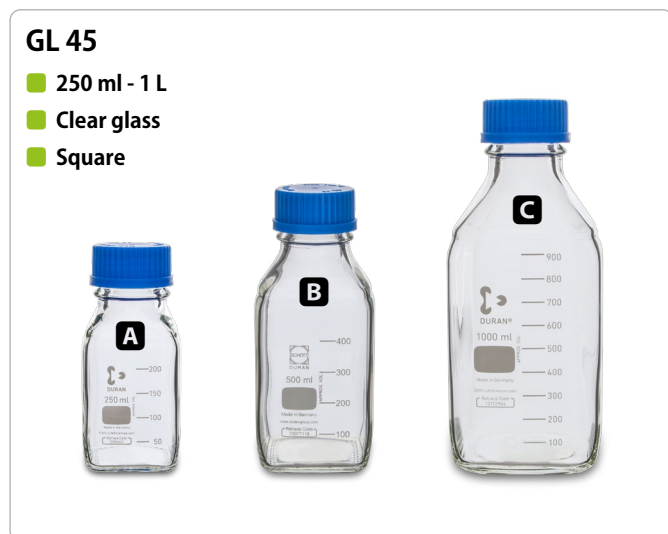


Fig.	Part No.	Description	Thread	Content	Glass Type	Form	Protective Coating
<b>A</b>	501 112	Laboratory bottle DURAN®, GL 45, 250 ml	GL 45	250 ml	Clear glass	Square	-
<b>B</b>	501 115	Laboratory bottle DURAN®, GL 45, 500 ml	GL 45	500 ml	Clear glass	Square	-
<b>C</b>	501 110	Laboratory bottle DURAN®, GL 45, 1 L	GL 45	1 Litre	Clear glass	Square	-
<b>D</b>	501 121	Laboratory bottle DURAN®, GL 45, 250 ml	GL 45	250 ml	Brown glass	Round	-
<b>E</b>	501 120	Laboratory bottle DURAN®, GL 45, 500 ml	GL 45	500 ml	Brown glass	Round	-
<b>F</b>	501 119	Laboratory bottle DURAN®, GL 45, 1 L	GL 45	1 Litre	Brown glass	Round	-
	501 123	Laboratory bottle DURAN®, GL 45, 2 L	GL 45	2 Litre	Brown glass	Round	-
<b>G</b>	199 011	Screw cap DURAN®	GL 45	-	-	-	-
<b>H</b>	501 127	Laboratory bottle, GL 28, 100 ml	GL 28	100 ml	Brown glass	Round	-
<b>I</b>	501 131	Laboratory bottle DURAN® YOUTILITY, GL 45, 1 L	GL 45	1 Litre	Clear glass	Ergon.	-
	501 130	Laboratory bottle DURAN® YOUTILITY, GL 45, 1 L	GL 45	1 Litre	Brown glass	Ergon.	-
<b>J</b>	501 154	Bottle Tag, GL 45, Multipack, 2x Blue, 2x Purple, 2x Green, 2x Red, 2x Orange, 2x Yellow, 2x Black, 2x White					

HPLC-Supply

HPLC-Disposal

Safety Funnels

Level Control

Containers

Accessory

Addendum

# Laboratory Glass Bottles Wide Mouth



## GLS 80

- 500 ml - 2 L
- Clear glass
- Round
- Wide mouth



### Clear Glass

- Storage capacity from 500 ml up to 2 L
- GLS 80, wide diameter of bottle neck

## GLS 80

- 500 ml - 2 L
- Brown glass
- Round
- Wide mouth



### Brown Glass

- Storage capacity from 500 ml up to 2 L
- GLS 80, wide diameter of bottle neck

Fig.	Part No.	Description	Thread	Content	Glass Type	Form	Protective Coating
<b>A</b>	<b>501 150</b>	Laboratory bottle DURAN®, GLS 80, 500 ml	GLS 80	500 ml	Clear glass	Round	-
<b>B</b>	<b>501 156</b>	Laboratory bottle DURAN®, GLS 80, 500 ml	GLS 80	500 ml	Brown glass	Round	-
<b>C</b>	<b>501 151</b>	Laboratory bottle DURAN®, GLS 80, 1 L	GLS 80	1 Litre	Clear glass	Round	-
<b>D</b>	<b>501 157</b>	Laboratory bottle DURAN®, GLS 80, 1 L	GLS 80	1 Litre	Brown glass	Round	-
<b>E</b>	<b>501 152</b>	Laboratory bottle DURAN®, GLS 80, 2 L	GLS 80	2 Litre	Clear glass	Round	-
<b>F</b>	<b>501 158</b>	Laboratory bottle DURAN®, GLS 80, 2 L	GLS 80	2 Litre	Brown glass	Round	-



# Laboratory Glass Bottles Purging Manifold

## **X** Negative Example

Open purging bottle

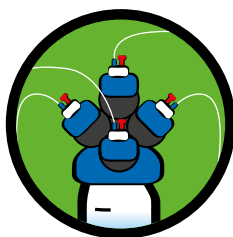


### Common purging process:

- When purging a HPLC system, Safety Caps with capillaries are hung loosely in the purging bottle
- Thus interrupt the SCAT system
- As a result, harmful vapours get into the laboratory ambient air and endanger work safety

## **✓** Positive Example

Hermetically sealed purging bottle



### Purging process with the SCAT purging manifold:

- Install up to 4 Safety Caps on your purging bottle for safe and easy handling. Capillaries are reliably fixed and solvent filters have enough space due to the wide GLS 80 opening.
- The SCAT system for solvent safety stays permanently closed, the "safety chain" remains intact during the purging process
- No dangers, no contamination - protects people, environment and HPLC system

## GLS 80, GL 45



**A** 106 660



**B** 306 509



### Flexible

- Simply close unused connections with the standard screw cap. (Not included in the scope of delivery).

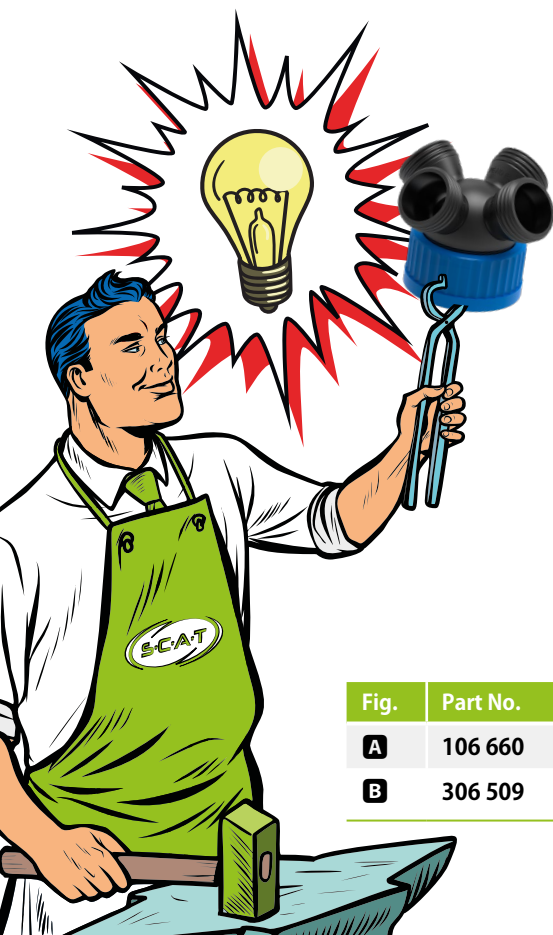


Fig.	Part No.	Description
<b>A</b>	106 660	Purging manifold WERNER, GLS 80 (f), 4x GL 45 (m), PE-HD-EL
<b>B</b>	306 509	Purging manifold NICOLE, GL 45 (f), 4x GL 45 (m), PE-HD-EL

HPLC-Supply

HPLC-Disposal

Safety Funnels

Level Control

Containers

Accessory

Addendum

# Canisters PE-HD

## GL 45, S 50

### GL 45

- 2.5 - 10 L
- PE-HD
- UN-Y

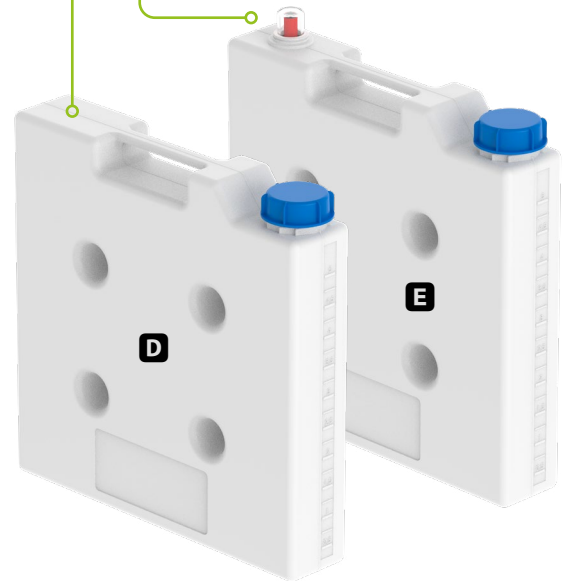


### S 50

- 5 L
- PP

#### Space-saving Canisters

- Only 65 mm wide!
- Optional with level control



#### Order also

- Base for 2 space-saving canisters



### Consistent with canisters

- Electrostatic conductive Canistes ..... from **page 142**
- Safety Waste Caps ..... from **page 68**
- Safety Funnels ..... from **page 94**
- Thread Adapters ..... from **page 164**
- Collecting Trays and Stirrers ..... from **page 148**

Fig.	Part No.	Thread	Content L	Material	Colour	UN Approval	Specific Feature	Dimensions in mm W x H x D
<b>A</b>	<b>107 950</b>	GL 45	2.5	PE-HD	Nature	Yes	UN-Y approval	115 x 210 x 150
<b>B</b>	<b>107 951</b>	GL 45	5	PE-HD	Nature	Yes	UN-Y approval	150 x 250 x 195
<b>C</b>	<b>107 952</b>	GL 45	10	PE-HD	Nature	Yes	UN-Y approval	190 x 305 x 230
<b>D</b>	<b>107 998</b>	S 50	5	PP	Nature	No	Space-saving	65 x 335 x 335
<b>E</b>	<b>108 945</b>	S 50	5	PP	Nature	No	With floater	65 x 405 x 335
<b>F</b>	<b>199 050</b>			Stainless steel	Steel			141 x 130 x 200

# Canisters PE-HD

## S 51, B 53, S 55

### S 51

- 5 L
- PE-HD
- UN-X



### B 53

- 2 L
- PE-HD



### S 55

- 5 - 10 L
- PE-HD
- UN-X
- UN-Y



### S 55

- 5 - 10 L
- F-PE-HD
- UN-X

#### Fluorinated Canister

- Against weight loss of content. Fluorination on both sides protect the canisters plastic walls from permeation of chemicals.



Fig.	Part No.	Thread	Content L	Material	Colour	UN Approval	Specific Feature	Dimensions in mm W x H x D
<b>A</b>	<b>107 958</b>	S 51	5	PE-HD	Nature	Yes	UN-X approval	145 x 250 x 190
<b>B</b>	<b>107 711</b>	B 53	2	PE-HD	Nature	No		119 x 260 x 119
<b>C</b>	<b>108 175</b>	S 55	5	PE-HD	Nature	Yes	UN-X approval	182 x 240 x 162
<b>D</b>	<b>107 957</b>	S 55	5	PE-HD	Nature	Yes	UN-Y approval	160 x 230 x 185
<b>E</b>	<b>107 955</b>	S 55	10	PE-HD	Nature	Yes	UN-Y approval	185 x 305 x 225
<b>F</b>	<b>107 933</b>	S 55	5	F-PE-HD	Nature	Yes	UN-X approval Fluorination on both sides	145 x 250 x 190
<b>G</b>	<b>108 189</b>	S 55	10	F-PE-HD	Nature	Yes	UN-X approval Fluorination on both sides	190 x 310 x 230

# Canisters PE-HD



## S 60/61

- 5-20 L
- PE-HD
- UN-X



## S 60/61

- 30 L
- PE-HD
- UN-Y



Fig.	Part No.	Thread	Content L	Material	Colour	UN Approval	Specific Feature	Dimensions in mm W x H x D
<b>A</b>	108 227	S 60/61	5	PE-HD	Nature	Yes	UN-X approval	164 x 235 x 185
<b>B</b>	107 731	S 60/61	12	PE-HD	Nature	Yes	UN-X approval	200 x 350 x 235
<b>C</b>	107 956	S 60/61	20	PE-HD	Nature	Yes	UN-X approval	260 x 390 x 289
<b>D</b>	108 056	S 60/61	20	PE-HD	Nature	No	With floater	260 x 455 x 285
<b>E</b>	107 959	S 60/61	30	PE-HD	Nature	Yes	UN-Y approval	290 x 400 x 380
<b>F</b>	108 115	S 60/61 & GL 45	30	PE-HD	Nature	No	Double closure	290 x 400 x 380

# Canisters PE-HD

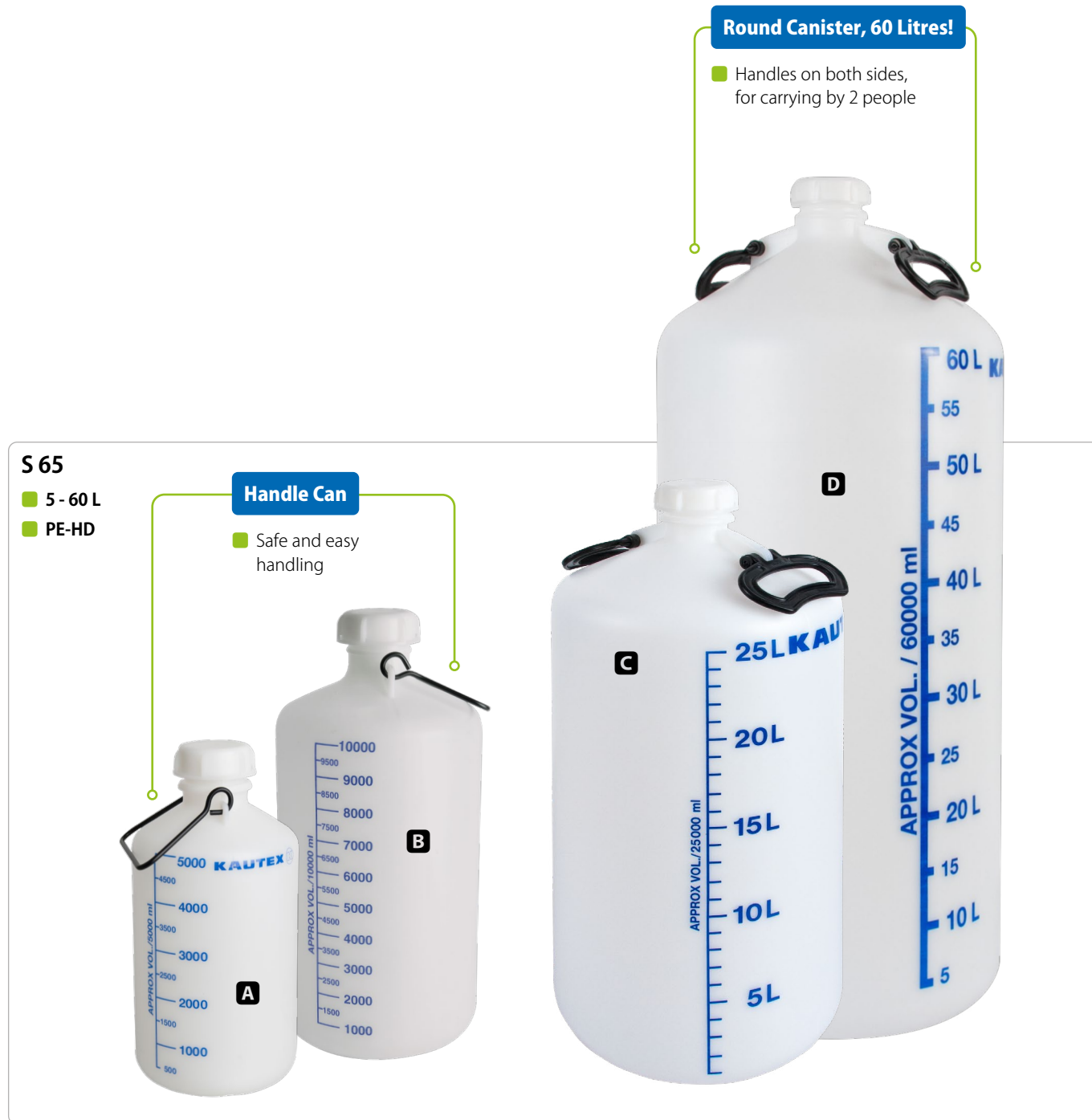


Fig.	Part No.	Thread	Content L	Material	Colour	UN Approval	Specific Feature	Dimensions in mm W x H x D
<b>A</b>	<b>107 722</b>	S 65	5	PE-HD	Nature	No	With handle and scale	167 x 330 x 167
<b>B</b>	<b>107 704</b>	S 65	10	PE-HD	Nature	No	With handle and scale	205 x 430 x 205
<b>C</b>	<b>107 720</b>	S 65	25	PE-HD	Nature	No	With carrying handles and scale	278 x 580 x 278
<b>D</b>	<b>107 721</b>	S 65	60	PE-HD	Nature	No	With carrying handles and scale	350 x 825 x 350

HPLC-Supply

HPLC-Disposal

Safety Funnels

Level Control

Containers

Accessory

Addendum



# Canisters PE-HD

## S 70/71, B 83

### S 70/71

- 20 - 60 L
- PE-HD
- UN-Y

#### Low Construction

- Space-saving

#### 60 Litres!

- Handles on both sides, for carrying by 2 people



### B 83

- 4 - 50 L
- PE-HD, PP
- UN-Y

#### Round Canister, 50 Litres!

- Handles on both sides, for carrying by 2 people



Fig.	Part No.	Thread	Content L	Material	Colour	UN Approval	Specific Feature	Dimensions in mm W x H x D
<b>A</b>	<b>107 713</b>	S 70/71	20	PE-HD	Nature	Yes	UN-Y approval	283 x 292 x 376
<b>B</b>	<b>107 710</b>	S 70/71	60	PE-HD	Nature	Yes	UN-Y approval	330 x 635 x 370
<b>C</b>	<b>107 712</b>	B 83	4	PE-HD	Nature	No		155 x 338 x 155
<b>D</b>	<b>107 706</b>	B 83	10	PP	Nature	No	With carrying handles	250 x 390 x 250
<b>E</b>	<b>107 730</b>	B 83	50	PP	Nature	No	With carrying handles	380 x 680 x 380

# Canisters PE-HD

## S 90, S 95

### S 90

- 10 L
- PE-HD
- UN-Y

#### Handle Can

- Safe and easy handling



**A**

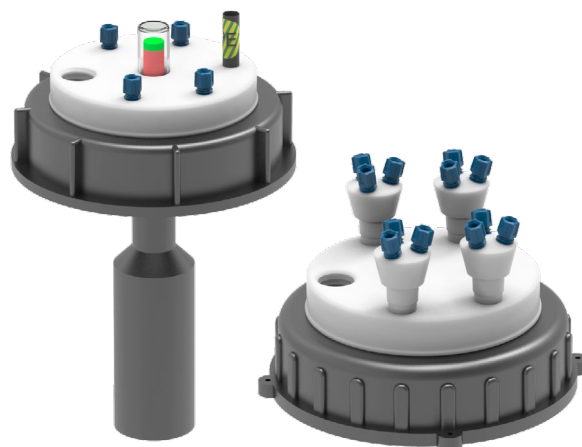


### XXL Safety Waste Caps

Safety Waste Caps in chapter HPLC-Disposal from **page 62**

Safety Waste Caps S 90 ..... on **page 84**

Safety Waste Caps S S 95 ..... on **page 85**



### S 95

- 5 - 20 L
- PE-HD
- UN-Y

#### Side-Handle

- Simplifies carrying or transposing



**B**



**C**

Fig.	Part No.	Thread	Content L	Material	Colour	UN Approval	Specific Feature	Dimensions in mm W x H x D
<b>A</b>	<b>108 020</b>	S 90	10	PE-HD	Nature	Yes	UN-Y approval	195 x 380 x 195
<b>B</b>	<b>107 707</b>	S 95	5	PE-HD	Nature	Yes	UN-Y approval	170 x 310 x 170
<b>C</b>	<b>107 733</b>	S 95	20	PE-HD	Nature	No		260 x 390 x 290

HPLC-Supply

HPLC-Disposal

Safety Funnels

Level Control

Containers

Accessory

Addendum

# Canisters

## Electrostatic conductive, PE-HD-EL



**S 50**

- 10 L
- PE-HD-EL
- UN-X

**Straight Opening**

- No angled thread adapters required

**Level Control**

- Integrated viewing strip shows the filling level

**S 50**

- 5 L
- PE-HD-EL

**Space-saving Canisters**

- Only 65 mm wide!
- Optional with level control

**Order also**

- Base for 2 space-saving canisters



### Consistent with canisters

- Do not forget grounding! Grounding cables on **page 166**
- Safety Waste Caps ..... from **page 62**
- Safety Funnels ..... from **page 100**
- Thread Adapters ..... from **page 164**
- Collecting Trays and Stirrers ..... from **page 148**

Fig.	Part No.	Thread	Content L	Material	Colour	UN Approval	Specific Feature	Dimensions in mm W x H x D
<b>A</b>	<b>108 421</b>	S 50	10	PE-HD-EL	Black	Yes	UN-X approval with viewing strip	190 x 315 x 230
<b>B</b>	<b>108 317</b>	S 50	5	PE-HD-EL	Black	No	Space-saving	65 x 335 x 335
<b>C</b>	<b>108 950</b>	S 50	5	PE-HD-EL	Black	No	With floater	65 x 405 x 335
<b>D</b>	<b>199 050</b>			Stainless steel	Steel			141 x 130 x 200

# Canisters

## Electrostatic conductive, PE-HD-EL



**S 60/61**

- 5 - 10 L
- PE-HD-EL
- UN-Y

**Straight Opening**

- No angled thread adapters required

**S 60/61**

- 10 L
- PE-HD-EL

**Colour Marking**

- Coloured marking at the grip surface
- Clearly separate different waste liquids from each other

**S 60/61**

- 10 L
- PE-HD-EL
- UN-Y

**Bestseller**

Fig.	Part No.	Thread	Content L	Material	Colour	UN Approval	Specific Feature	Dimensions in mm W x H x D
<b>A</b>	<b>108 329</b>	S 60/61	5	PE-HD-EL	Black	Yes	UN-Y approval, straight opening	165 x 241 x 195
<b>B</b>	<b>108 330</b>	S 60/61	10	PE-HD-EL	Black	Yes	UN-Y approval, straight opening	192 x 311 x 232
<b>C</b>	<b>107 953</b>	S 60/61	10	PE-HD-EL	Black	Yes	UN-Y approval	185 x 265 x 290
<b>D</b>	<b>108 216</b>	S 60/61	10	PE-HD-EL	Black	No	With red marking strip	185 x 265 x 290
<b>E</b>	<b>108 217</b>	S 60/61	10	PE-HD-EL	Black	No	With green marking strip	185 x 265 x 290
<b>F</b>	<b>108 215</b>	S 60/61	10	PE-HD-EL	Black	No	With yellow marking strip	185 x 265 x 290
<b>G</b>	<b>108 214</b>	S 60/61	10	PE-HD-EL	Black	No	With blue marking strip	185 x 265 x 290

- HP/LC-Supply
- HP/LC-Disposal
- Safety Funnels
- Level Control
- Containers
- Accessory
- Addendum

# Canisters

## Electrostatic conductive, PE-HD-EL



**S 60/61**

- 10 L
- PE-HD-EL

**Level Control**

- Integrated floater signalizes when the container is full




**S 60/61**

- 10 L
- PE-HD-EL

**Sleeve for Sensor**

- Removable sleeve
- Suitable rod sensor part no. 108 178 see **page 123**



**S 60/61**

- 20 L
- PE-HD-EL
- UN-Y

**Straight Opening**

- No angled thread adapters required

**Level Control**

- Integrated floater signalizes when the container is full






Fig.	Part No.	Thread	Content L	Material	Colour	UN Approval	Specific Feature	Dimensions in mm W x H x D
<b>A</b>	<b>108 042</b>	S 60/61	10	PE-HD-EL	Black	No	With floater	185 x 265 x 290
<b>B</b>	<b>108 042-S1</b>	S 60/61	10	PE-HD-EL	Black	No	With sleeve for sensor 108 178	185 x 265 x 290
<b>C</b>	<b>108 331</b>	S 60/61	20	PE-HD-EL	Black	Yes	UN-Y approval, straight opening	290 x 399 x 245
<b>D</b>	<b>108 027</b>	S 60/61	20	PE-HD-EL	Black	Yes	UN-Y approval	185 x 500 x 290
<b>E</b>	<b>108 043</b>	S 60/61	20	PE-HD-EL	Black	No	With floater	185 x 500 x 290



# Canisters

## Electrostatic conductive, PE-HD-EL

# S 60/61, S 70/71, S 90

### S 60/61

- 30 L
- PE-HD-EL
- UN-Y

#### Level Control

- Integrated floater signalizes when the container is full



Safety Note: As per TRGS 727, Para. 4.5.5, the largest container volume permitted within Zone 1, for non-conducting containers, is 5 litres. There may also be no deviation from this regulation when working with aqueous-based solutions that are highly conductive, as work involving exposed flammable liquids creates an explosive atmosphere close to the container, as is generally defined for Zone 1.

### S 90

- 10 L
- PE-HD-EL
- UN-Y

#### Handle Can

- Safe and easy handling

#### Level Control

- Integrated viewing strip shows the filling level



Handle of non-conductive plastic. The grounding strap is required to securely ground the canister. This can be found on **page 167**.

### S 70/71

- 60 L
- PE-HD-EL
- UN-Y

#### Level Control

- Integrated floater signalizes when the container is full

#### Handles

- Handles on both sides, for carrying by 2 people



Fig.	Part No.	Thread	Content L	Material	Colour	UN Approval	Specific Feature	Dimensions in mm W x H x D
A	108 192	S 60/61	30	PE-HD-EL	Black	Yes	UN-Y approval	240 x 455 x 364
B	108 193	S 60/61	30	PE-HD-EL	Black	No	With floater	240 x 455 x 364
C	107 940	S 70/71	60	PE-HD-EL	Black	Yes	UN-Y approval	330 x 625 x 396
D	107 740	S 70/71	60	PE-HD-EL	Black	No	With floater	330 x 690 x 395
E	108 420	S 90	10	PE-HD-EL	Black	Yes	UN-Y approval With viewing strip	195 x 380 x 195



# Politainer

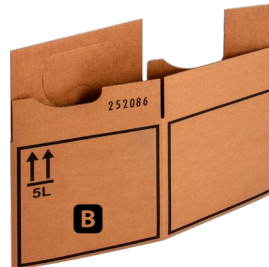
## Space-saving foldable Canisters

### Good for the laboratory - good for the climate!

The Politainer can ideally be stored space-saving prior to filling and it is stackable when filled. The Politainer unfolds automatically during filling – the integrated handle ensures a safe transport and emptying free of danger. Through the small volume in its original condition you save shipping costs. The carton can be used several times and that increases cost effectiveness. The combi-packaging uses 50 % – 75 % less material than rigid container and is therefore environmentally friendly. When using the strong covering box the Politainer is UN approved.

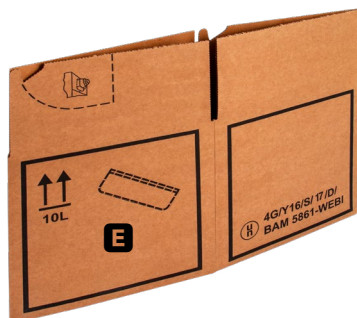
#### GL 38

- 5 L
- PE-LD / EVA Copolymer
- UN-Y



#### GL 38

- 10 L
- PE-LD / EVA Copolymer
- UN-Y



#### Clever & Smart

- Space-saving storage
- Quickly ready for use



# Politainer Space-saving foldable Canisters

## S 60/61



### Safety Waste Caps

S 60/61 on **page 78**.



Fig.	Part No.	Description	Thread	Content L	Material	Colour	UN-Y Approval	Dimensions in mm W x H x D
<b>A</b>	107 330	Politainer	GL 38	5	PE-LD / EVA Copolymer	Nature	Yes, but only with Box 107 334	178 x 178 x 178
<b>B</b>	107 334	Box for Politainer		5	Carton	Nature	Yes	189 x 186 x 190
<b>C</b>	107 331	Politainer	GL 38	10	PE-LD / EVA Copolymer	Nature	Yes, but only with Box 107 335	228 x 228 x 228
<b>D</b>	107 332	Politainer	S 60/61	10	PE-LD / EVA Copolymer	Nature	Yes, but only with Box 107 335	228 x 228 x 228
<b>E</b>	107 335	Box for Politainer		10	Carton	Nature	Yes	236 x 236 x 236
<b>F</b>	107 333	Politainer	S 60/61	20	PE-LD / EVA Copolymer	Nature	Yes, but only with Box 107 336	285 x 285 x 285
<b>G</b>	107 336	Box for Politainer		20	Carton	Nature	Yes	290 x 290 x 306

HP LC-Supply

HP LC-Disposal

Safety Funnels

Level Control

Containers

Accessory

Addendum

## Collecting Trays The Safety Waste Assurance!

**A** 117 983



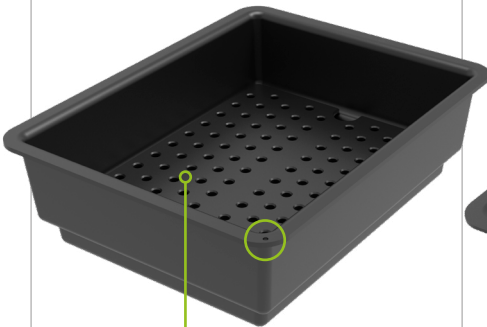
**B** 117 984



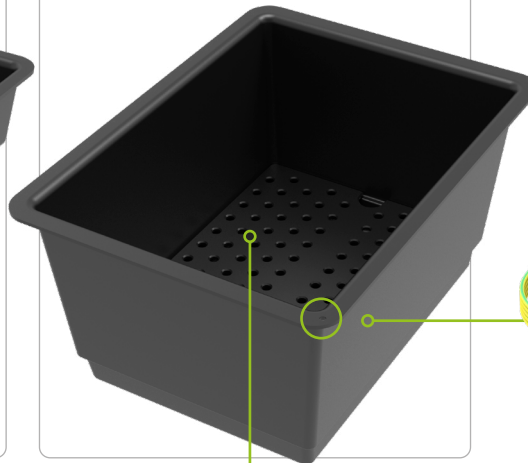
**C** 108 981



**D** 117 985



**E** 117 986



**PE-HD-EL**

- Connection for grounding cables
- Grounding cables can be found on **page 166**

**Base Insert**

- Waste canisters stay dry
- Removable for cleaning

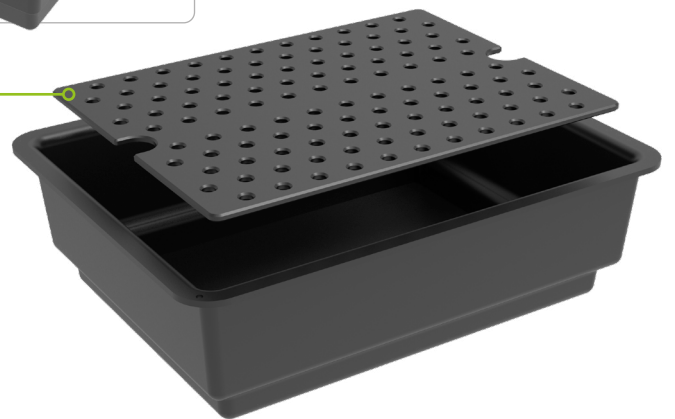


Fig.	Part No.	Description	Material	Colour	Inner Dimensions in mm W x H x D	Outer Dimensions in mm W x H x D
<b>A</b>	<b>117 983</b>	Collecting tray	PE-HD	White	235 x 160 x 335	300 x 170 x 400
<b>B</b>	<b>117 984</b>	Collecting tray	PE-HD	White	290 x 200 x 385	340 x 210 x 465
<b>C</b>	<b>108 981</b>	Collecting tray	PE-HD-EL	Black	200 x 200 x 300	225 x 215 x 325
<b>D</b>	<b>117 985</b>	Collecting tray with base insert	PE-HD-EL	Black	285 x 95 x 385	355 x 135 x 445
<b>E</b>	<b>117 986</b>	Collecting tray with base insert	PE-HD-EL	Black	295 x 200 x 415	365 x 240 x 490

# Containers Spouts

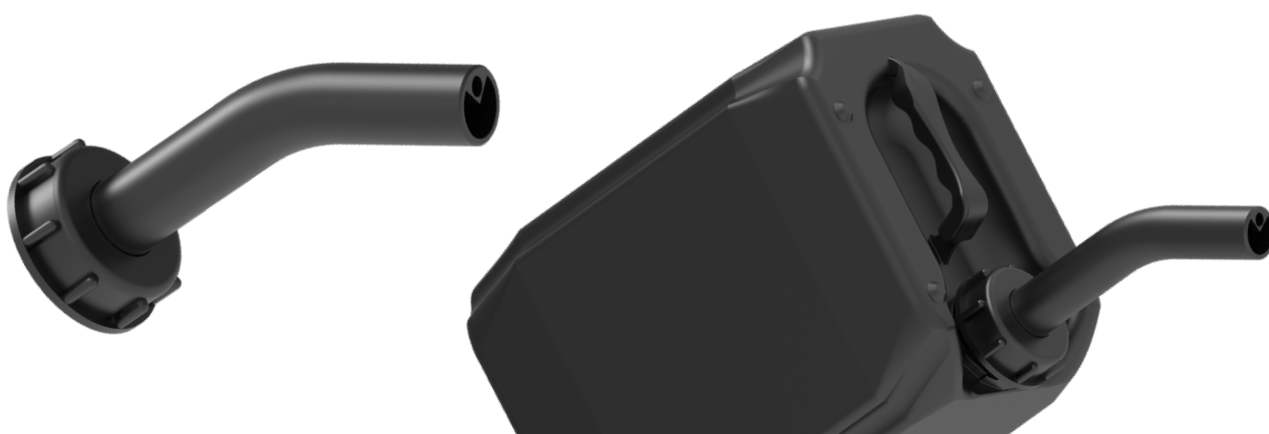


Fig.	Part No.	Description	Thread	Material	Colour
<b>A</b>	<b>610 499</b>	Flexible spout, with safety vent	S 55	PE-HD	White/Red
<b>B</b>	<b>610 500</b>	Rigid spout, with safety vent	S 55	PE-HD	White/Red
<b>C</b>	<b>610 501</b>	Flexible spout, with safety vent	S 60/61	PE-HD	White/Red
<b>D</b>	<b>610 502</b>	Rigid spout	S 60/61	PE-HD	Blue
<b>E</b>	<b>610 504</b>	Rigid spout, <b>electrostatic conductive</b> , with safety vent	S 60/61	PE-HD-EL	Black
<b>F</b>	<b>610 503</b>	Flexible spout, with safety vent	S 70/71	PE-HD	Black

HPLC-Supply

HPLC-Disposal

Safety Funnels

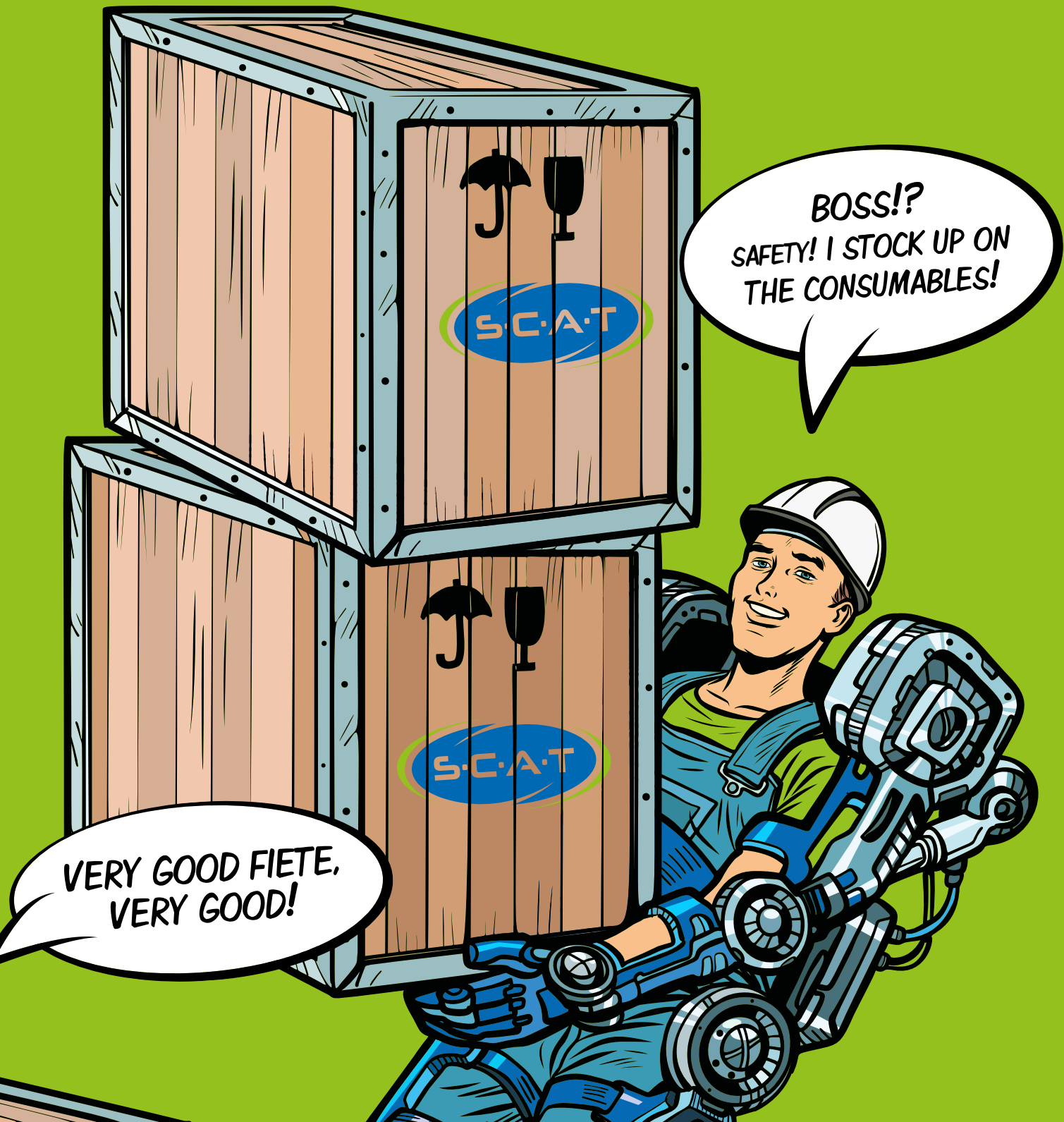
Level Control

Containers

Accessory

Addendum





BOSS!?  
SAFETY! I STOCK UP ON  
THE CONSUMABLES!

VERY GOOD FIETE,  
VERY GOOD!

## Safety can be reordered!

We have developed a lot of accessories which help you to work quickly, safely and economically. All products are specially modulated to the SCAT safety system. Our accessories are of high quality and proven in practice.

# Accessory

Adapt the system to your requirements!

- ✓ All suitable with the SCAT System
- ✓ Consumables as Reserve Packs
- ✓ Adapter for all purposes
- ✓ Special Tools



# Expendable Valves and Filters must be Exchanged in Time!

Never miss an exchange again with the practical exchange indicators.

The SCAT System protects you from solvent vapours and keeps your HPLC System clean. Air valves and exhaust filters continually block the passage of vapour and dirt. When a filter becomes saturated, it can no longer adsorb further particles. So regularly exchange filters and valves - for optimum safety!

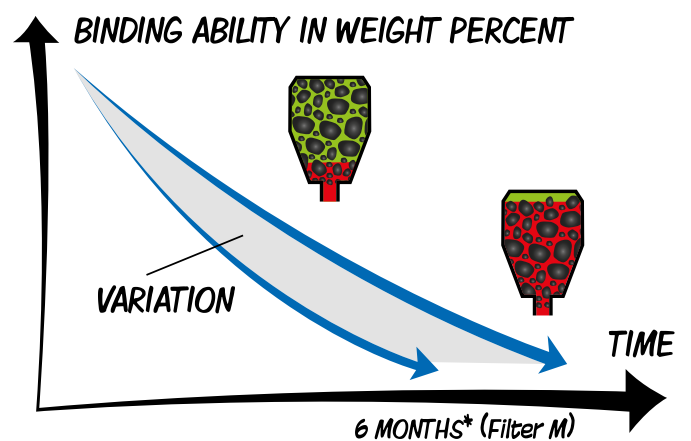
## Valve exchange for trouble-free HPLC operation!

The air ventilation valve is constructed for a maximum lifetime, when used with HPLC. The actual lifetime achieved is also dependent upon the nature of the solvents used, the surrounding air, the temperature and flowrate. As these factors can vary considerably, we recommend an exchange every 6 Months, in order to ensure for problem-free operation.



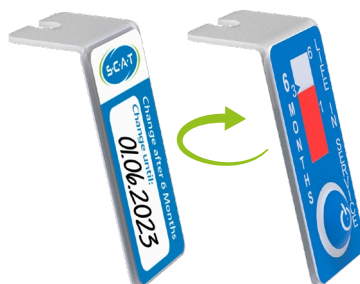
## Expendable filters.

The exhaust filter is optimized for the adsorption of solvent vapours from eluents, as typically used for HPLC. The actual lifetime of the filter is also dependent upon the composition of the waste material being produced, its temperature and flowrate. These factors can vary considerably from customer to customer, and/or according to the nature of the application. In order to be on the safe side, we recommend an exchange every 3 (S); 6 (M); 12 (L) Months\*, for optimum protection.



\*Operational lifetime with typical HPLC flowrates of 1.5 - 4.0 ml per minute.

## Consumables Ordering Informations



**Clever! Simply turn it around and use the Labeling Field.**

Would you like to note down the expiry date of your valve? No problem - simply turn the clip around and use the labeling field.

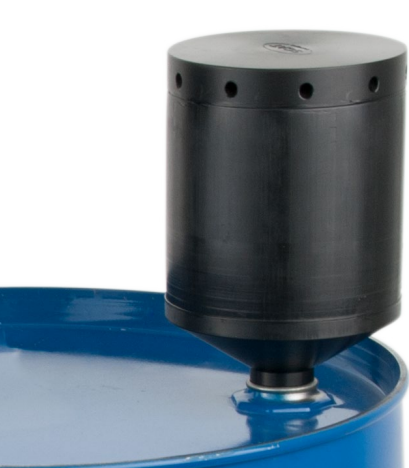
Fig.	Part No.	Description	Thread	Unit	Operational Lifetime
<b>A</b>	<b>317 010</b>	Air ventilation valve, for Safety Caps, with exchange clip	UNF 1/4" 28G	1	6 Months
	<b>397 008</b>	Air ventilation valves, Reserve Pack (8 pcs.)	UNF 1/4" 28G	8	8x 6 Months
	<b>397 010</b>	Air ventilation valves, Reserve Pack (10 pcs.)	UNF 1/4" 28G	10	10x 6 Months
	<b>397 050</b>	Air ventilation valves, Reserve Pack (50 pcs.)	UNF 1/4" 28G	50	50x 6 Months
	<b>397 100</b>	Air ventilation valves, Reserve Pack (100 pcs.)	UNF 1/4" 28G	100	100x 6 Months



Fig.	Part No.	Description	Thread	Unit	Operational Lifetime
	<b>410 534</b>	Exhaust Filter S, V3.0, with splash protection and change indicator	GL 14	1	3 Months
<b>B</b>	<b>490 335</b>	Exhaust Filter S, V3.0, with splash protection and change indicator	GL 14	4	4x 3 Months
	<b>407 982</b>	Exhaust Filter M, V3.0, with splash protection and change label	GL 14	1	6 Months
	<b>410 535</b>	Exhaust Filter M, V3.0, with splash protection and change indicator	GL 14	1	6 Months
<b>C</b>	<b>490 336</b>	Exhaust Filter M, V3.0, with splash protection and change indicator	GL 14	2	2x 6 Months
	<b>490 914</b>	Exhaust Filter M, V3.0, with splash protection and change label	GL 14	2	2x 6 Months
<b>D</b>	<b>407 986</b>	Exhaust Filter L, V3.0, with splash protection and change indicator	GL 14	1	12 Months
	<b>490 986</b>	Exhaust Filter L, V3.0, with splash protection and change indicator	GL 14	2	2x 12 Months
	<b>407 983</b>	Exhaust Filter L, V3.0, with splash protection and change label	GL 14	1	12 Months
	<b>490 915</b>	Exhaust Filter L, V3.0, with splash protection and change label	GL 14	2	2x 12 Months



Fig.	Part No.	Size	Thread	Unit	Op. Lifetime
<b>E</b>	<b>108 985</b>	XL	G 3/4"	1	6 Months
<b>F</b>	<b>108 986</b>	XXL	BCS 70x6	1	12 Months
	<b>108 987</b>	XXL	R2" BSP/G2" (m) + BCS 56x4 (m)	1	12 Months



## Adapters for Exhaust Filter Connections

### Space problems? Offset adapter!

Space problem in the lab or on small Safety Waste Caps? Not an issue – attach the exhaust air filter to the waste containers in any position. Practical, space-saving and flexible. With the extension **A**, you can create more freedom of movement when attaching tubes. The adapters **A B C D** can be combined with each other.



### Usage with other systems!

You are already using a system e.g. from VICI or Phenomenex? This adapter allows you to use SCAT exhaust filters.



**G**

**A** 107 621



**B** 107 624



**C** 107 627



**D** 107 622



Adapter UNF 1/4"-28G to GL 14

Blind plug

**E** 107 620

- Simply closes the exhaust air connection when not in use



**F** 107 632

- Connectivity for HPLC capillaries to the exhaust air connection



Fig.	Part No.	Description	Thread 1	Thread 2	Material
<b>A</b>	107 621	Offset adapter, extension for exhaust filter, GL 14 (f) to GL 14 (m)	GL 14 (f)	GL 14 (m)	PE-HD-EL
<b>B</b>	107 624	Offset adapter 90°, for exhaust filter, GL 14 (f) to GL14 (m)	GL 14 (f)	GL 14 (m)	PE-HD-EL
<b>C</b>	107 627	Offset adapter 45°, for exhaust filter, GL 14 (f) to GL14 (m)	GL 14 (f)	GL 14 (m)	PE-HD-EL
<b>D</b>	107 622	Offset adapter 90°, long, for exhaust filter, GL 14 (f) to GL 14 (m)	GL 14 (f)	GL 14 (m)	PE-HD-EL
<b>E</b>	107 620	Blind plug for the exhaust filter connection	GL 14 (m)	-	PTFE
<b>F</b>	107 632	Adapter capillary connection to exhaust filter connection	GL 14 (m)	UNF 1/4" 28G (f)	PTFE
<b>G</b>	108 181	Exhaust filter adapter, suitable for connecting a SCAT exhaust filter on a Waste Cap of third party manufacturers (e.g. Vici)	GL 14 (f)	UNF 1/4" 28G (m)	PE-HD

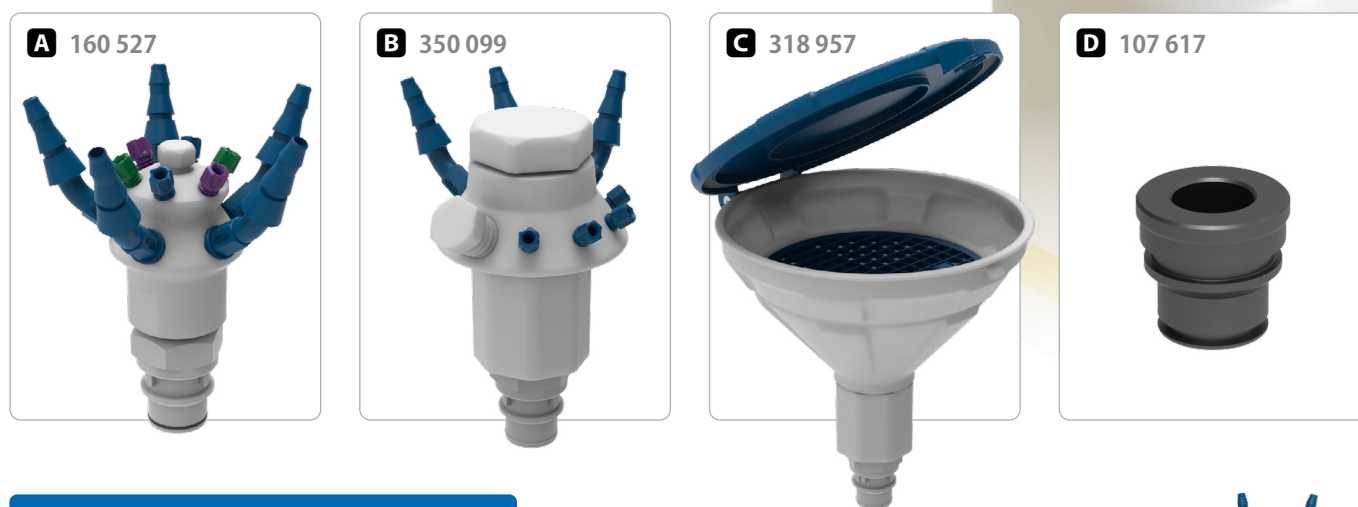


## Adapter for JUSTRITE® Containers

### SCAT Europe Waste Systems fit on Containers of JUSTRITE®

Proven SCAT Europe safety at JUSTRITE® containers. Suitable adapters and CPC®- couplings.

#### For quick couplings made of plastic



#### For quick couplings made of stainless steel



Fig.	Part No.	Description	Capillary connections	Tube connections	Connection for Exhaust Filter	Material	Unit
	107 628	4-way-collector for plastic coupling	3x	1x	-	PTFE / PFA /PP	1
<b>A</b>	160 527	12-way-collector for plastic coupling	6x	6x	-	PP	1
<b>B</b>	350 099	LISA for plastic coupling	4x	3x	1x	PTFE	1
<b>C</b>	318 957	MARCO for plastic coupling	-	-	-	PE-HD	1
<b>D</b>	107 617	Adapter SCAT Exhaust Filter to plastic coupling	-	-	1x	PE-HD-EL	1
<b>E</b>	160 524	12-way-collector for steel coupling	6x	6x	-	PTFE-EL / stainless steel	1
<b>F</b>	107 631	4-way-collector for steel coupling	3x	1x	-	PTFE	1
<b>G</b>	107 610	Adapter SCAT Exhaust Filter to steel coupling	-	-	1x	PE-HD-EL	1

HPLC-Supply

HPLC-Disposal

Safety Funnels

Level Control

Containers

Accessory

Addendum

## Capillary Connection of Safety Caps and Safety Waste Caps Fittings, Blind Plugs, Connectors



Scope of delivery:  
 ■ 2x 1.6 mm, green  
 ■ 2x 2.3 mm, violet  
 ■ 2x 3.2 mm, blue

Fig.	Part No.	Description	Capillary Size Ø OD	Material	Colour	Unit
<b>A</b>	<b>107 061</b>	Fitting for capillary connection	1.6 mm	PFA	Green	5
<b>B</b>	<b>107 059</b>	Fitting for capillary connection	2.3 mm	PFA	Violet	5
<b>C</b>	<b>107 063</b>	Fitting for capillary connection	3.2 mm	PFA	Blue	5
<b>D</b>	<b>160 501</b>	Blind plug for capillary connection	-	PFA	Colourless	10
	<b>160 502</b>	Blind plug for capillary connection	-	PFA	Colourless	5
<b>E</b>	<b>107 041</b>	Fitting for capillary connection	1.6 mm	PTFE	White	10
<b>F</b>	<b>107 042</b>	Fitting for capillary connection	2.3 mm	PTFE	White	10
<b>G</b>	<b>107 043</b>	Fitting for capillary connection	3.2 mm	PTFE	White	10
<b>H</b>	<b>160 145</b>	Capillary connector	1.6 / 2.3 / 3.2 mm	PTFE/PFA	White/Blue	1
<b>I</b>	<b>160 134</b>	2-in-1 Connector for capillaries	3.2mm	PTFE/PFA	White/Blue	1

Fig.	Part No.	Description	For Tube Diameter Ø ID	Material	Colour	Unit
<b>J</b>	<b>117 816</b>	Tube Connector, straight	6 - 8 mm ID	PP	Colourless	1

# Capillary Connection - Safety Caps - Preparative HPLC Fittings, Blind Plugs

**A 107 045**



For Safety Cap:

- 308 032
- 309 032
- 310 032

■ Ø 4.76 mm (UNF 5/16")

**B 160 503**



For Safety Cap:

- 308 032
- 309 032
- 310 032

■ Blind plug (UNF 5/16")

**C 107 044**




For Safety Cap:

- 307 007
- 307 008
- 307 009

■ Ø 6.35 mm (NPT 1/8")

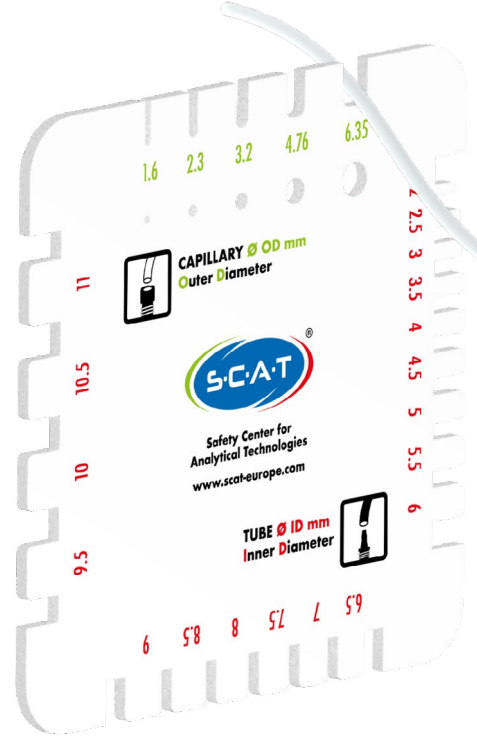
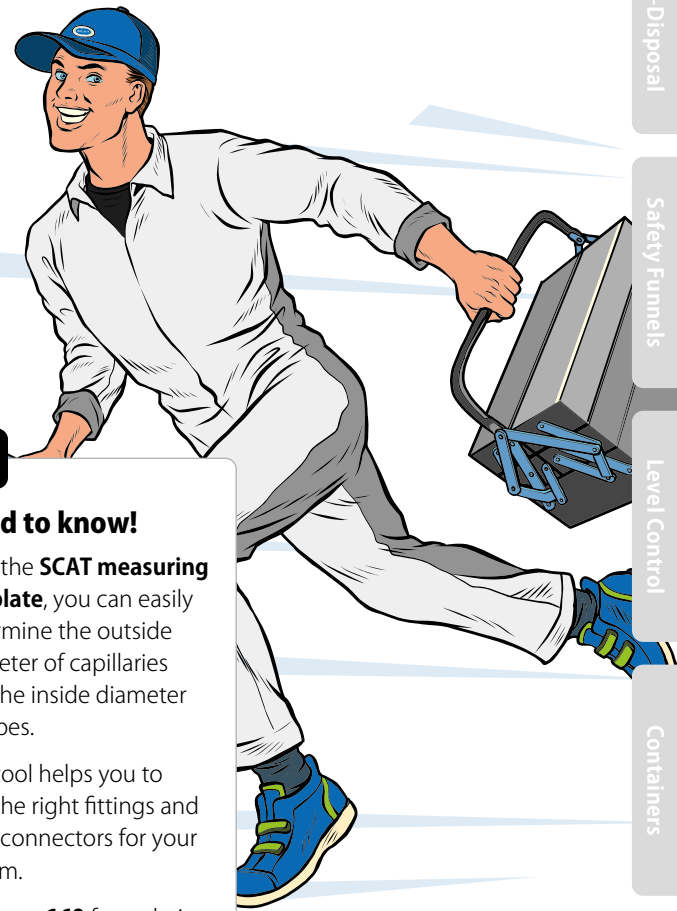
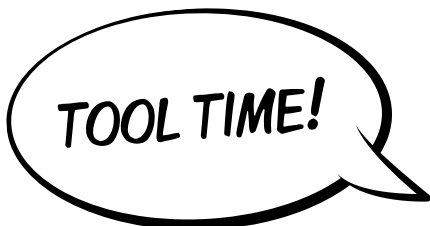
**D 160 506**



For Safety Cap:

- 307 007
- 307 008
- 307 009

■ Blind plug (NPT 1/8")



**Good to know!**

With the **SCAT measuring template**, you can easily determine the outside diameter of capillaries and the inside diameter of tubes.

This tool helps you to find the right fittings and tube connectors for your system.

See **page 169** for ordering information.

Fig.	Part No.	Description	Capillary Size Ø OD	Thread	Material	Colour	Unit
	<b>107 047</b>	Fitting for preparative HPLC	4.0 mm	UNF 5/16"	PTFE	White	1
<b>A</b>	<b>107 045</b>	Fitting for preparative HPLC	4.76 mm	UNF 5/16"	PTFE	White	1
<b>B</b>	<b>160 503</b>	Blind Plug for preparative HPLC	-	UNF 5/16"	PTFE	White	10
	<b>160 515</b>	Blind Plug for preparative HPLC	-	UNF 5/16"	PTFE	White	5
	<b>107 046</b>	Fitting for preparative HPLC	6.0 mm	NPT 1/8"	PTFE	White	1
<b>C</b>	<b>107 044</b>	Fitting for preparative HPLC	6.35 mm	NPT 1/8"	PTFE	White	1
<b>D</b>	<b>160 506</b>	Blind Plug for tube connection	-	NPT 1/8"	PTFE	White	1

HPLC-Supply

HPLC-Disposal

Safety Funnels

Level Control

Containers

Accessory

Addendum

## Accessory for the Tube Connection

### Tube Connectors



Images A - K are of scale 1:1.

Just add the tube and determine the suitable connector.

Fig.	Part No.	Description	For Tube Diameter	Material	Unit
<b>A</b>	<b>117 808</b>	Stepped Tube Connector, curved	5 - 11,5 mm ID	PP	1
<b>B</b>	<b>160 143</b>	Tube Connector, curved	6,4 - 8 mm ID	PTFE	1
<b>C</b>	<b>160 142</b>	Tube Connector, straight	6,4 - 8 mm ID	PTFE	1
<b>D</b>	<b>107 811</b>	Tube Connector, straight	2 - 3 mm ID	PP	1
<b>E</b>	<b>107 812</b>	Tube Connector, straight	3 - 4 mm ID	PP	1
<b>F</b>	<b>107 813</b>	Tube Connector, straight	4 - 6 mm ID	PP	1
<b>G</b>	<b>107 814</b>	Tube Connector, straight	5 - 7 mm ID	PP	1
<b>H</b>	<b>107 816</b>	Tube Connector, straight	6,2 - 7,5 mm ID	PP	1
<b>I</b>	<b>107 817</b>	Tube Connector, straight	9,5 - 10 mm ID	PP	1
<b>J</b>	<b>107 808</b>	Tube Connector, angled	6,4 - 8 mm ID	PP	1
<b>K</b>	<b>107 810</b>	Tube Connector, angled	9,5 - 10 mm ID	PP	1

Tube connector for the capillary connection, see page 156.

## Accessory for the Tube Connection Adapters

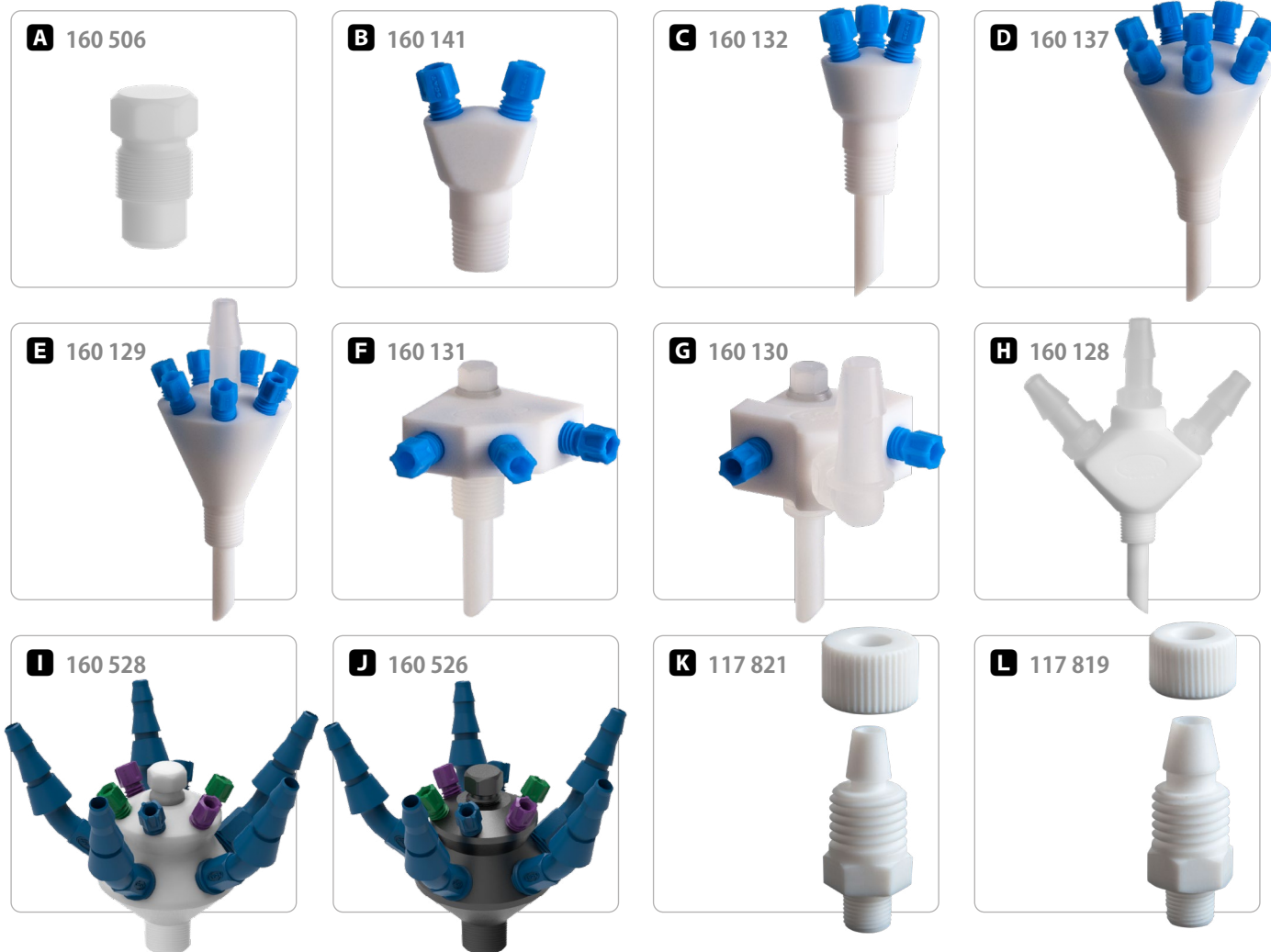


Fig.	Part No.	Description	For Tube Diameter (Scope of Delivery)		Material	Unit
<b>A</b>	<b>160 506</b>	Blind Plug for tube connection	-	-	PTFE	1
<b>B</b>	<b>160 141</b>	2-in-1 Collector	2.3 / 3.2 mm OD (2x)	-	PTFE / PFA	1
<b>C</b>	<b>160 132</b>	3-in-1 Collector	2.3 / 3.2 mm OD (3x)	-	PTFE / PFA	1
<b>D</b>	<b>160 137</b>	8-in-1 Collector	2.3 / 3.2 mm OD (8x)	-	PTFE / PFA	1
<b>E</b>	<b>160 129</b>	8-in-1 Collector	2.3 / 3.2 mm OD (7x)	6 - 8 mm ID (1x)	PTFE / PFA / PP	1
<b>F</b>	<b>160 131</b>	3-in-1 Collector, sideways	2.3 / 3.2 mm OD (3x)	-	PTFE / PFA / PP	1
<b>G</b>	<b>160 130</b>	3-in-1 Collector, sideways	2.3 / 3.2 mm OD (2x)	6,4 - 8 mm ID (1x)	PTFE / PFA / PP	1
	<b>160 139</b>	2-in-1 Collector, sideways	-	6,4 - 8 mm ID (2x)	PTFE / PP	1
	<b>160 138</b>	3-in-1 Collector, sideways	-	6,4 - 8 mm ID (3x)	PTFE / PP	1
<b>H</b>	<b>160 128</b>	3-in-1 Collector, straight	-	6,2 - 7,5 mm ID (3x)	PTFE / PP	1
<b>I</b>	<b>160 528</b>	12-in-1 Collector	1.6 / 2.3 / 3.2 mm OD (6x)	5,0 - 11,5 mm (6x)	PTFE	1
<b>J</b>	<b>160 526</b>	12-in-1 Collector	1.6 / 2.3 / 3.2 mm OD (6x)	5,0 - 11,5 mm (6x)	PTFE-EL	1
<b>K</b>	<b>117 821</b>	Tube Connector, straight, + sealing	-	6,5 mm ID	PTFE	1
<b>L</b>	<b>117 819</b>	Tube Connector, straight, + sealing	-	8 mm ID	PTFE	1



## Further Systems Collector

### 3-in-1 collector for t-piece

The collector locks the open T-piece of the HPLC system gastight and avoids the leakage of harmful vapours. Collector, tube-piece and 3x Fittings for capillaries with  $\varnothing$  1.6 mm outer diameter are included in the scope of delivery.



#### Capillaries and tools.

Suitable capillaries and tools you will find on **page 168**.



#### Good to know!

The "3-in-1 Collector for T-piece" is suitable for systems of the type: **VWR-Hitachi Chromaster**

Fig.	Part No.	Description	Unit
<b>A</b>	<b>199 010</b>	3-in-1 collector for t-piece incl. tube-piece and 3x fittings for capillaries with $\varnothing$ 1.6 mm OD	1

## Adapter Access to Containers during running Operation

### Direct access to your containers

With this adapter, connecting each ND9 short thread cap of your sample bottles with the SCAT safety system is easy. This way you have access to the contents of your supply and waste containers even during ongoing operations, without evaporation or contamination.



Fig.	Part No.	Description	Material	Unit
A	160 146	Adapter for septum caps with short thread ND9	PTFE	1



### Luer adapter

B 160 191



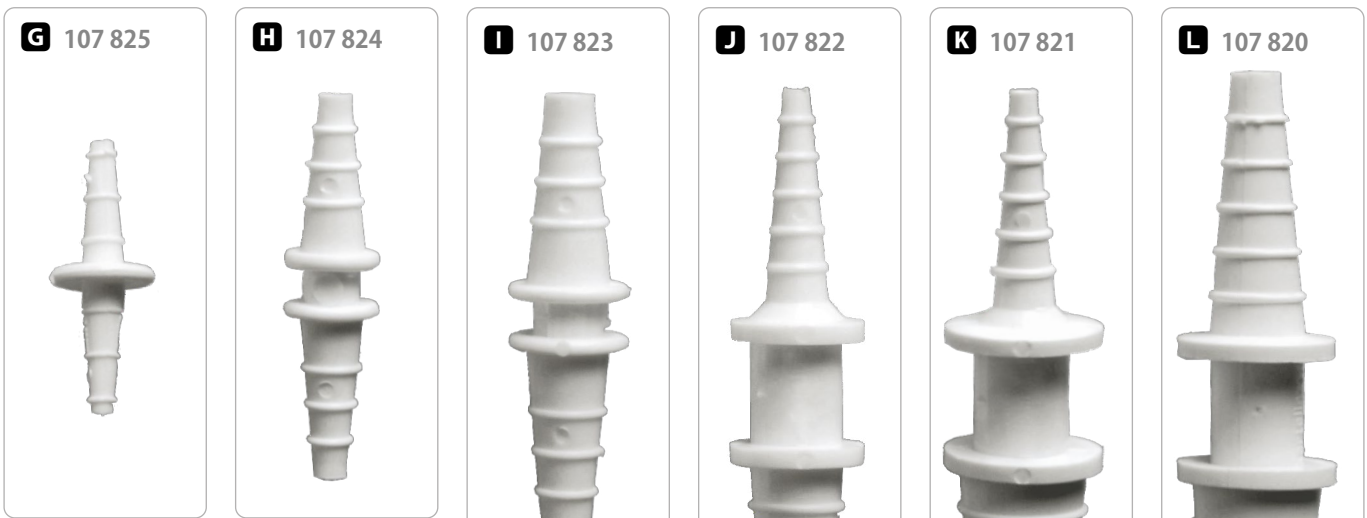
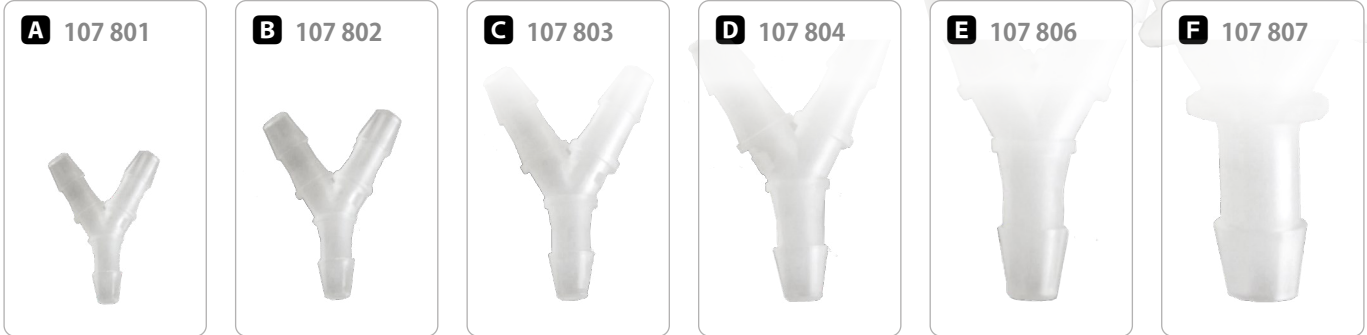
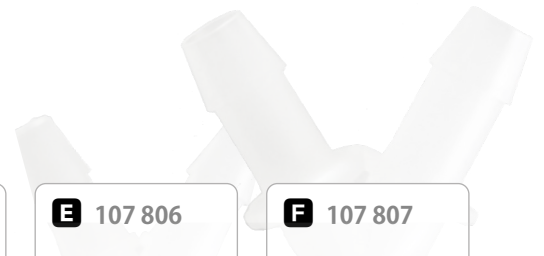
#### Good to know!

With the Luer Adapter, you can easily add or remove liquids without opening the cap. Suitable for the use of Safety Caps with a shut-off valve, see [page 47](#).



Abb.	Part No.	Description	Material	Unit
B	160 191	Luer adapter for the capillary connector	PP	1

## Tube Connectors To put On



### Good to know!

Illustrations  
**A - M**  
are of **scale 1:1**

Simply put on  
the tube and  
find the right  
connector.

Fig.	Part No.	Description	Diameter		Material	Unit
<b>A</b>	<b>107 801</b>	Y-connector	3 mm		PP	1
<b>B</b>	<b>107 802</b>	Y-connector	4 mm		PP	1
<b>C</b>	<b>107 803</b>	Y-connector	5 mm		PP	1
<b>D</b>	<b>107 804</b>	Y-connector	6 mm		PP	1
<b>E</b>	<b>107 806</b>	Y-connector	9 mm		PP	1
<b>F</b>	<b>107 807</b>	Y-connector	11 mm		PP	1
<b>G</b>	<b>107 825</b>	Conical connector	3 - 5 mm	3 - 5 mm	PP	1
<b>H</b>	<b>107 824</b>	Conical connector	4 - 8 mm	4 - 8 mm	PP	1
<b>I</b>	<b>107 823</b>	Conical connector	7 - 10 mm	7 - 10 mm	PP	1
<b>J</b>	<b>107 822</b>	Conical connector	4 - 8 mm	8 - 12 mm	PP	1
<b>K</b>	<b>107 821</b>	Conical connector	4 - 8 mm	12 - 16 mm	PP	1
<b>L</b>	<b>107 820</b>	Conical connector	8 - 12 mm	12 - 16 mm	PP	1
<b>M</b>	<b>107 826</b>	Connector, spherical	5 - 16 mm	7.5 - 16 mm	PP	1

## Tube Connectors Quick-Lock Connectors

### With one "click"!

The Quick-Lock Connectors allow safe and quick connection of tubing and make bottle changes even easier. The bottles are rapidly disconnected with a single "click" and can be refilled at a safe location.

Thanks to the integrated valve function, the closed safety system is maintained even when a tube is disconnected.

The practical CPC quick lock connectors can be used for all SCAT safety systems.



Fig.	Part No.	Description	Capillary Diameter	Material	Unit
<b>A</b>	<b>360 190</b>	Quick-Lock connector (m)	1.6 mm, 2.3 mm, 3.2 mm OD, works with 360 179	PP	1
<b>B</b>	<b>360 179</b>	Quick-Lock connector (f)	1.6 mm, 2.3 mm, 3.2 mm OD, works with 360 190 and 360 180	PP	1
<b>C</b>	<b>360 180</b>	Quick-Lock Connector (m) for screwing into the standard connectors of Safety Caps (UNF 1/4" 28G)	1.6 mm, 2.3 mm, 3.2 mm OD, works with 360 179	PP	1
	<b>360 189</b>	Quick-Lock Connector Set I contains 360 190 ( <b>A</b> ) and 360 179 ( <b>B</b> )	1.6 mm, 2.3 mm, 3.2 mm OD	PP	1
	<b>360 183</b>	Quick-Lock Connector Set II contains 360 179 ( <b>B</b> ) and 360 180 ( <b>C</b> )	1.6 mm, 2.3 mm, 3.2 mm OD	PP	1

HPLC-Supply

HPLC-Disposal

Safety Funnels

Level Control

Containers

Accessory

Addendum

# Thread Adapter for Containers

## If it doesn't fit - we'll make it fit.

Our numerous thread adapters are well-proven assistants through the daily working routine in laboratory and production.



### Online configurator!

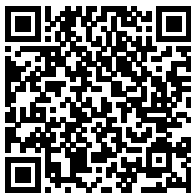
You can easily find the right adapter using the configurator at [www.scat-europe.com](http://www.scat-europe.com). Products > Accessories > Thread adapter. Or simply scan the QR code.

**FILTER**

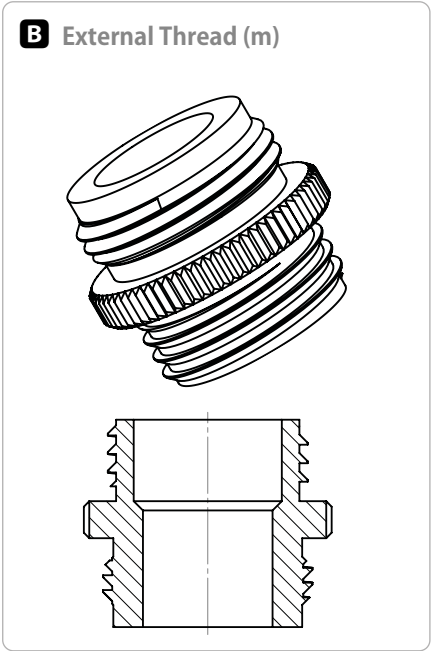
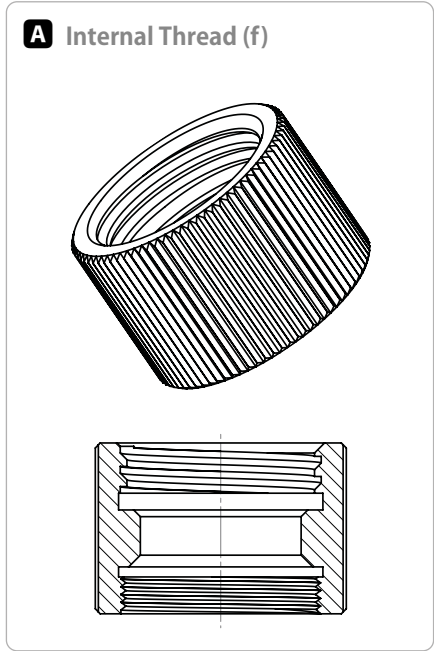
Main material

Thread size

Thread bottom



[www.scat-europe.com](http://www.scat-europe.com)



Typ	Part No.	Thread 1	Thread 2	Material	Colour
<b>A</b>	<b>107 024</b>	S 55 (f)	R 2" fine (f)	PP	Green
<b>A</b>	<b>107 023</b>	S 60/61 (f)	R 2" fine (f)	PP	Yellow
<b>A</b>	<b>108 444</b>	63 mm ASTM (f)	R 2" fine (f)	PP	White
<b>A</b>	<b>107 025</b>	S 70/71 (f)	R 2" fine (f)	PP	Brown

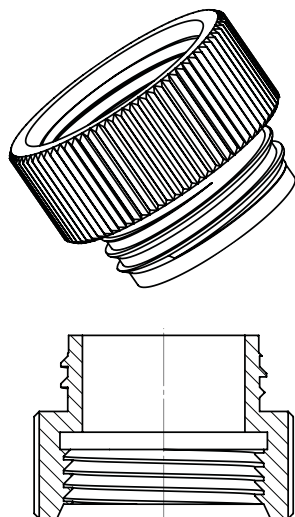
Typ	Part No.	Thread 1	Thread 2	Material	Colour
<b>B</b>	<b>107 014</b>	GL 45 (m)	R 2" BSP (m)	PP	Colourless
<b>B</b>	<b>107 016</b>	GL 45 (m)	R 2" BSP (m)	PTFE	White
<b>B</b>	<b>107 015</b>	GL 45 (m)	2" Tri-Sure (m)	PP	Colourless
<b>B</b>	<b>107 017</b>	GL 45 (m)	2" Tri-Sure (m)	PTFE	White
<b>B</b>	<b>108 022</b>	S 60/61 (m)	2" BSP (m)	PP	Black
<b>B</b>	<b>108 029</b>	S 60/61 (m)	2" Tri-Sure (m)	PP	Colourless





## Thread Adapter for Containers

### C Internal/external thread (f/m)



### C 108 058

#### The angled-adapter for canisters.

Compensates for sloping canister openings. Place laboratory bottles simply and safely on the sieve of the funnel and let them drain.



Typ	Part No.	Thread 1	Thread 2	Material	Colour
C	108 060	S 40 (m)	GL 45 (f)	PTFE	White
C	107 996	GL 45 (m)	GL 32 (f)	PP	Colourless
C	107 993	GL 45 (m)	GL 32 (f)	PTFE	White
C	107 995	GL 45 (m)	GL 38 (f)	PP	Colourless
C	107 992	GL 45 (m)	GL 38 (f)	PTFE	White
C	107 994	GL 45 (m)	S40 / GL 40 (f)	PP	Colourless
C	107 991	GL 45 (m)	S40 / GL 40 (f)	PTFE	White
C	107 093	GL 45 (m)	S 51 (f)	PP	Colourless
C	107 099	GL 45 (m)	S 55 (f)	PP	Colourless
C	107 090	GL 45 (m)	S 60/61 (f)	PP	Colourless
C	107 079	GL 45 (m)	S 70/71 (f)	PP	Colourless
C	117 030	GL 45 (m)	38 / 430	PTFE	White
C	107 028	GL 45 (m)	R 1 1/2" (f)	PP	Colourless
C	107 080	S 51 (m)	S 47 x 4 (f)	PP	Colourless
C	107 092	S 51 (m)	S 55 (f)	PP	Colourless
C	107 086	S 51 (m)	S 60/61 (f)	PP	Colourless
C	107 078	S 55 (m)	S40 / GL 40 (f)	PP	Colourless
C	117 091	S 55 (m)	S40 / GL 40 (f)	PTFE	White
C	107 084	S 55 (m)	S 50 (f)	PTFE	Colourless
C	107 095	S 55 (m)	S 51 (f)	PP	Colourless
C	117 095	S 55 (m)	S 51 (f)	PTFE	White
C	107 094	S 55 (m)	GL 45 (f)	PP	Colourless
C	117 094	S 55 (m)	GL 45 (f)	PTFE	White
C	107 089	S 55 (m)	S 60/61 (f)	PP	Colourless
C	108 058	<b>S 60/61 (m) angled</b>	<b>S 60/61 (f)</b>	<b>PE-HD-EL</b>	<b>Black</b>
C	108 145	S 60/61 (m)	S 50 (f)	PE-HD-EL	Black
C	107 097	S 60/61 (m)	S 51 (f)	PTFE	Colourless
C	108 146	S 60/61 (m)	S 51 (f)	PE-HD-EL	Black
C	107 096	S 60/61 (m)	S 55 (f)	PP	Colourless
C	108 021	S 60/61 (m)	2" BSP (f)	PP	Grey
C	107 091	S 60/61 (m)	B 63 (f)	PP	Colourless
C	107 074	S 60/61 (m)	S 65 (f)	PP	Colourless
C	107 026	S 60/61 (m)	R 3" Schütz coarse (f)	PP	Grey
C	107 027	S 60/61 (m)	R 3" Werit fine (f)	PP	Colourless
C	107 088	S 65 (m)	63 mm ASTM (f)	PP	Colourless
C	108 147	S 60/61 (m)	S 71 (f)	PE-HD-EL	Black
C	107 018	S 90 (m)	S 100 / BB 70 (f)/MIR	PE-HD	Colourless
C	107 085	R 1 1/2" (m)	GL 45 (f)	PP	Colourless
C	107 021	BCS 70x6 (m)	R 2" fine (f)	PP	Blue
C	107 022	BCS 56x4 (m)	R 2" fine (f)	PP	Orange

## Erdung

### Grounding Cables

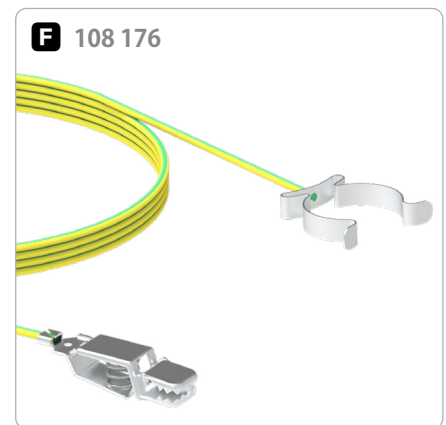
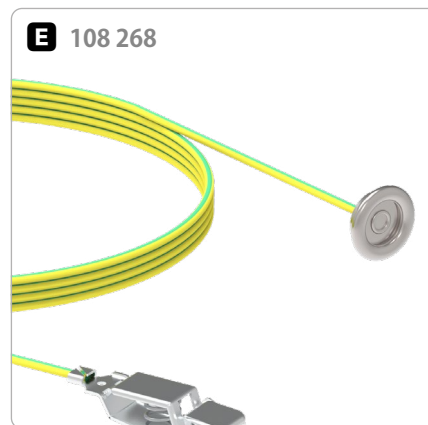
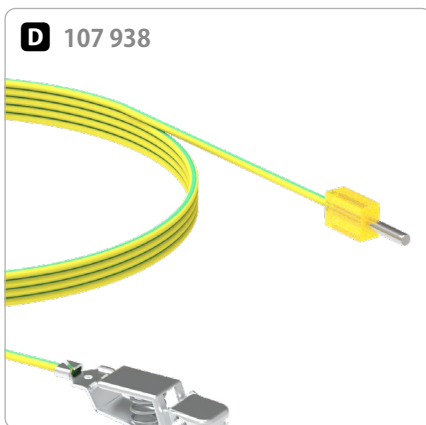
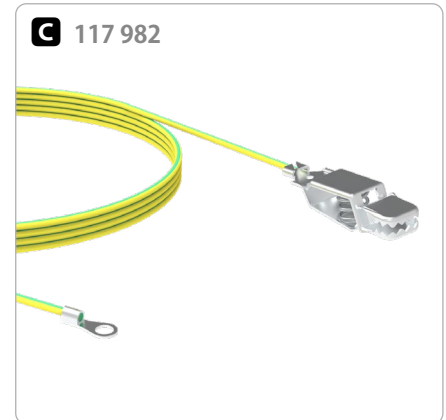
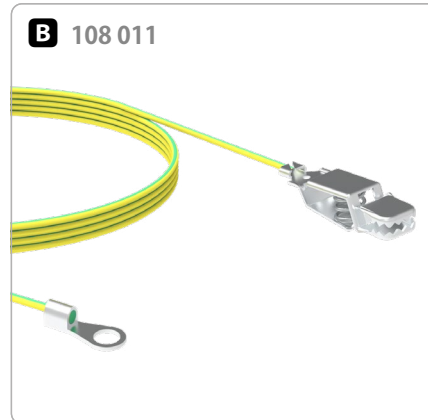
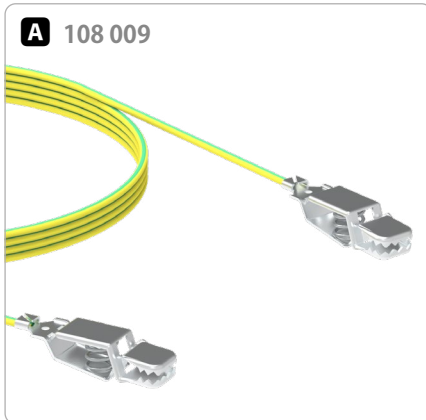


Abb.	Part No.	Description	Assembling	Length
<b>A</b>	<b>108 009</b>	Grounding cable	2 clamps	1.5 m
<b>B</b>	<b>108 011</b>	Grounding cable	1 clamp, 1 connection ring (Ø 10 mm)	1.5 m
<b>C</b>	<b>117 982</b>	Grounding cable	1 clamp, 1 connection ring (Ø 5 mm)	1.5 m
<b>D</b>	<b>107 938</b>	Grounding cable	1 clamp, 1 plug for Safety Waste Cap ground connection	1.5 m
	<b>108 294</b>	Grounding cable	1 clamp, 1 MC connector 90 degrees angled	1.5 m
	<b>108 093</b>	Grounding cable	Spiral grounding cable (1 Megaohm) with 10 mm press stud connector	1.8 m
<b>E</b>	<b>108 268</b>	Grounding cable	1 clamp, 1 press stud connector (Ø 10 mm)	2.0 m
<b>F</b>	<b>108 176</b>	Grounding cable	1 clamp, 1 grounding clip for Ø 32 mm pipe, suitable for SymLine pipe system, incl. mounting material	3.0 m

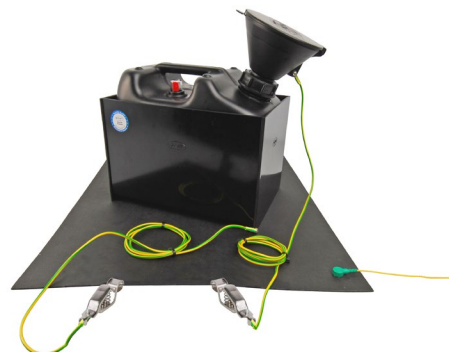
Abb.	Part No.	Description	Unit
<b>G</b>	<b>108 092</b>	EU earthing plug for isolated ground receptacle, 1x press stud connector, 2x 10 mm connector	1
	<b>108 281</b>	UK earthing plug for isolated ground receptacle, 1x press stud connector, 2x 10 mm connector	1
<b>H</b>	<b>108 099</b>	Anti-static mat, conductive. With grounding cable (press stud connector). Dimensions: 610 x 1220 x 3 mm	1
<b>I</b>	<b>108 096</b>	Ground strap for canisters with S 90 thread (108 420), incl. ground cable with clamp. Material: Stainless steel	1

## Grounding Grounding Accessory

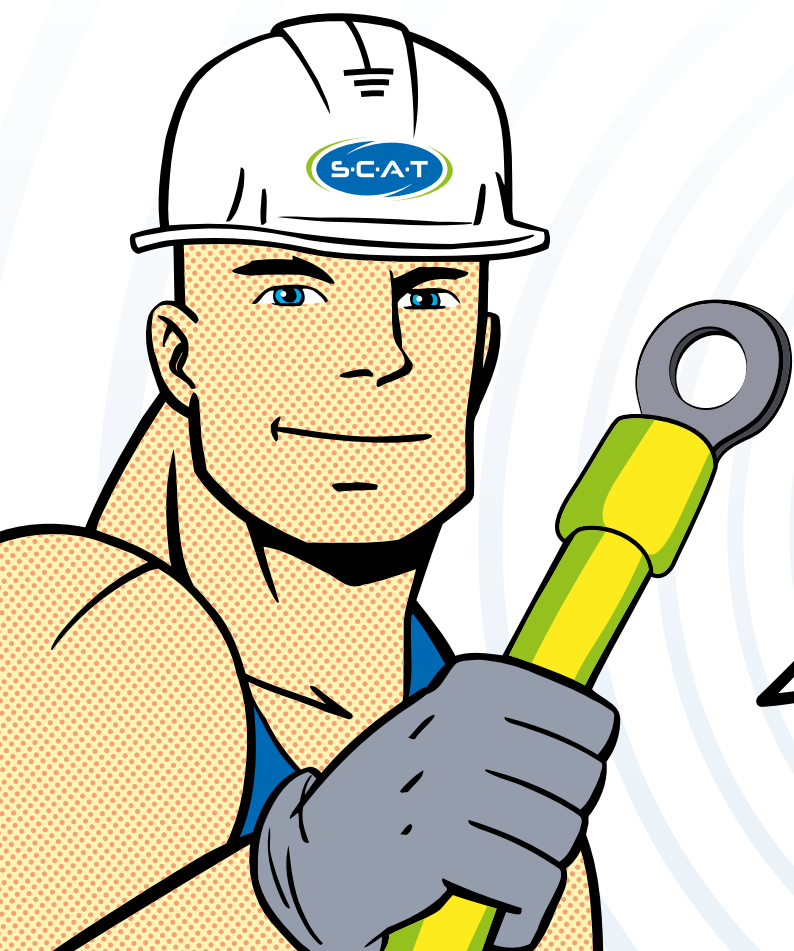
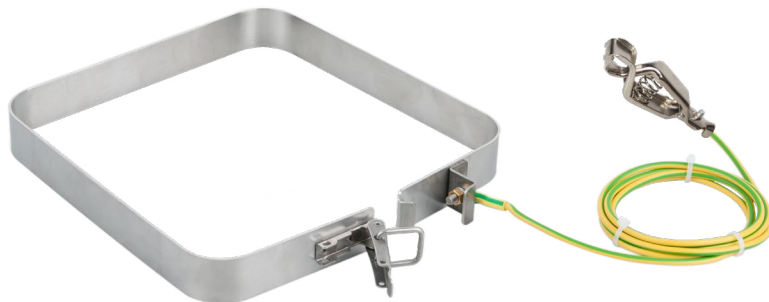
**G** 108 092



**H** 108 099



**I** 108 096



## Tubes and Capillaries

**A** 108 015**B** 108 018**C** 108 017**D** 108 016

Fig.	Part No.	Description	Diameter	Material	Length
<b>A</b>	<b>108 015</b>	Conductive plastic tube, flexible (spiral)	∅ ID = 9 mm, ∅ OD = 13 mm	PFA	1 m
	<b>108 019</b>	Conductive plastic tube, smooth	∅ ID = 10 mm, ∅ OD = 12 mm	PTFE	1 m
<b>B</b>	<b>108 018</b>	Conductive plastic tube, smooth	∅ ID = 8 mm, ∅ OD = 10 mm	PTFE	1 m
<b>C</b>	<b>108 017</b>	Conductive plastic tube, smooth	∅ ID = 6 mm, ∅ OD = 8 mm	PTFE	1 m
<b>D</b>	<b>108 016</b>	Conductive plastic tube, smooth	∅ ID = 4 mm, ∅ OD = 6 mm	PTFE	1 m

**E** 461 056**F** 461 055**G** 461 054**H** 461 053

Fig.	Part No.	Description	Material	Length
<b>E</b>	<b>461 056</b>	Corrugated tube, for leak connection of various HPLC systems, ∅ ID = 6.5 mm	PP	1 m
<b>F</b>	<b>461 055</b>	Capillary, ∅ OD = 3.2 mm, ∅ ID = 1.6 mm	PTFE	3 m
<b>G</b>	<b>461 054</b>	Capillary, ∅ OD = 2.3 mm, ∅ ID = 1.7 mm	PTFE	3 m
<b>H</b>	<b>461 053</b>	Capillary, ∅ OD = 1.6 mm, ∅ ID = 1.0 mm	PTFE	3 m
	<b>461 065</b>	Capillary, ∅ OD = 4.76 mm, ∅ ID = 3.76 mm	PTFE	3 m
	<b>461 066</b>	Capillary, ∅ OD = 6.35 mm, ∅ ID = 4.75 mm	PTFE	3 m

# Capillaries Suction Filter and Tools

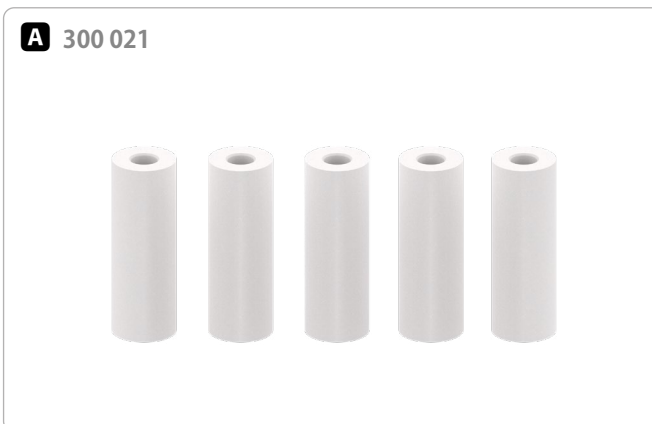


Fig.	Part No.	Description	Unit
<b>A</b>	<b>300 021</b>	Suction filter HPLC solvent filter UHMW-PE, for Ø 1/8" (Ø 3.2 mm OD) pore size 20 µm	5
	<b>300 022</b>	Suction filter HPLC solvent filter PFA/PTFE, for Ø 1/8" (Ø 3.2 mm OD) pore size 5 µm	5

## Special tools

Measuring template, installation wrench for fittings and capillary cutter incl. replacement blade.

Fittings and capillaries are not included in the scope of delivery.

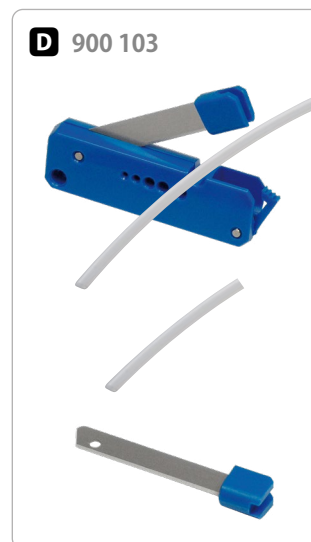
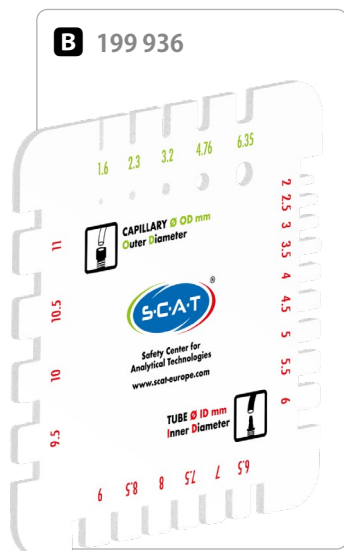


Fig.	Part No.	Description	Material	Colour
<b>B</b>	<b>199 936</b>	SCAT measuring template for capillaries & tubes	Hard PVC	White
<b>C</b>	<b>160 500</b>	Installation wrench, hexagonal (for PFA fittings)	Aluminium	Aluminium
<b>D</b>	<b>900 103</b>	CleanCut capillary cutter including replacement blade	PP, Stainless steel	Blue

HPLC-Supply

HPLC-Disposal

Safety Funnels

Level Control

Containers

Accessory

Addendum



BE WELL INFORMED...



...AND NOTHING  
CAN GO  
WRONG!

## More Helpful Informations about our Products.

What should you consider when using our products? What type of thread should your new SCAT component have? Be guided by our tables, symbols and other useful tips.

# Addendum

- ✓ Thread Identification
- ✓ Safety Instructions
- ✓ Terms & Conditions

HPLC-Supply

HPLC-Disposal

Safety Funnels

Level Control

Containers

Accessory

Addendum

## Thread Identification

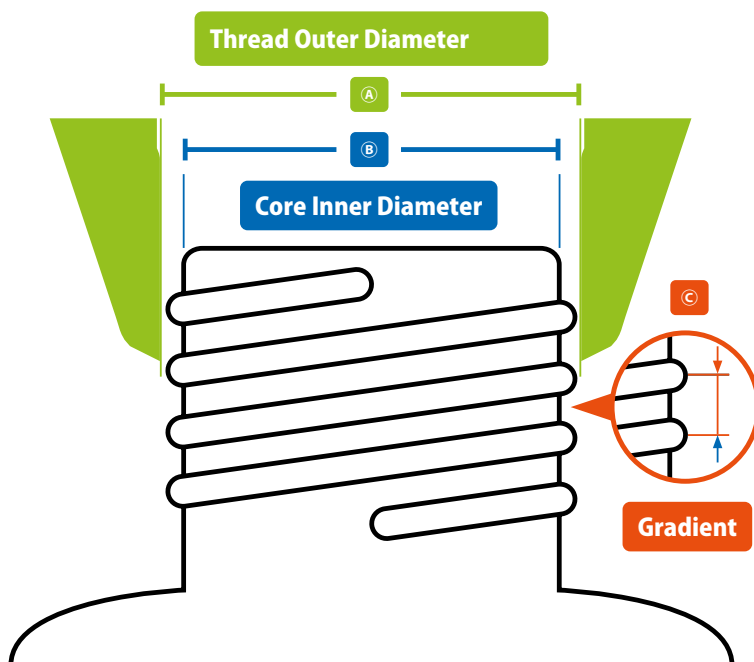
### Container Threads

#### Container threads

SCAT Safety Caps are available for a wide variety of differing container threads. On the following pages you will find tables for determining thread sizes, together with a helpful overview of typical thread types. It is best to use a slide gauge.

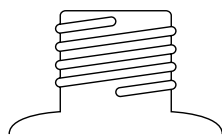
#### Instruction, identification of threads

Use the measured distances below to determine the outer diameter of the thread <sup>Ⓐ</sup> or the core inner diameter of the container opening <sup>Ⓑ</sup>.



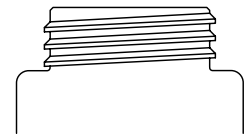
#### Round Thread, Example:

- Bottle thread (GL or GLS)
- Common standard for laboratory bottles



#### Saw Thread, Example:

- Canisters (S-Thread)
- Nalgene containers
- Barrels (Mauser, Trisure, BCS-Threads)
- GPI Standard (Glass Packaging Institute)
- Other plastic containers



Note: All the measurements and values given here can vary up to 0.5 mm, dependent upon the manufacturer involved (due to manufacturing tolerances). Brand names and trademarks are the property of the respective owners. The brand names and protected trademarks mentioned here are simply of descriptive nature.

Ø A Thread Outer Diameter		Ø B Core Diameter	© Gradient			
mm max.	mm min.	mm max.	in mm	Norm	Thread	Norm Thread Comments (also re. brand names, trademarks)
28.00	27.50	25.98	3.00	DIN 168-1	GL 28	Chromsystems®, Recipe®, 500 ml Buffer from Sigma®
32.00	31.30	29.30	4.00	DIN 168-1	GL 32 (glass)	For containers of the brand Duran®
32.00	31.50	29.00	3.00		S 32 (plastic)	-
37.49	36.88	35.10	4.23	GPI / SPI	GL 38/ GPI 38-400 (glass) (short)	For containers of the brands Wheaton® and Nalgene®
38.00	37.50	35.00	3.00	DIN 6063-2	GL 38 short (foldable canister)	4 L BDH bottle, Fulltime® Reagents
38.00	37.50	35.00	3.00	DIN 6063-1	S 38 (plastic)	2.5 L canister from Recipe®, HPLC-P Water, 1 litre Biosolve®, Fresenius Kabi® 10 L
37.49	36.88	35.10	4.23	GPI / SPI	GPI 38-430 (glass) (long)	Wheaton®, Nalgene® 4-edge 500 ml plastic bottle
40.00	39.30	37.30	4.00	DIN 168-1	GL 40 (glass)	For containers of the brand Merck®
41.00	39.50	37.00	3.50	DIN 6063-1	S 40/41 (plastic)	Due to the tolerances involved, a GL 40 cap will often fit on to an S 40 container of the brand Metrohm® / Merck®
42.00	41.50	38.00	4.00		S 42	The designation DIN42 is often written on the cap, Agro Paris Tech 51, Polimoon™, Nalgene®
45.00	44.30	42.30	4.00	DIN 168-1	GL 45	The most common thread for laboratory glass bottles
45.00	44.30	41.00	4.00	DIN 6063-1 DIN 6063-2	S 45	Due to the tolerances involved, a GL 45 cap will fit on to an S 45 thread
44.30	39.70	40.80	4.00	DIN45	DIN45	-
50.00	49.30	46.00	4.00	DIN 6063-1	S 50	Space-saving canister
51.00	49.00	47.00	4.00		S 51	Almost identical to S 50, but the outer diameter of the container thread (OD=⊘) is significantly different. The designation DIN50 is written on the cap.
54.00	53.50	47.50	6.35	53B	B 53	For containers of the brands Nalgene® and Polimoon™
53.80	53.20	49.50	5.00	DIN51	S 55	Designation 51 / DIN51 / HP51 is often written on the cap
60.00	59.20	54.00	6.00	DIN 6063-1	S 60/61	The designation 61, Mauser® 13, RPC Containers® C59PP / DIN61 is often written on the cap
62.51	61.62	60.12	4.23	GPI / SPI	B 63 / GPI 63-415	For containers of the brand Nalgene®
65.00	64.30	59.00	6.00		S 65	For containers of the brand Kautex® (round canisters)
71.00	69.30	65.00	6.00	DIN71	S 70/71	Designation 71, Rieke® 70 mm is often written on the cap
80.00	79.00	77.00	15P5	(DIN 168-1) short	GLS 80	Typical laboratory bottle with wide neck, short thread with 3 thread ends
89.18	88.29	79.00	12.70	83B	B 83	For containers of the brands Nalgene®, Kautex®, Foxx® and Carboy 80 mm
90.00	89.30	84.00	6.00		S 90	The designation D90 is often written on the cap
95.00	93.50	89.00	7.00		S 95	-
106.00	104.00	95.00	6.00		105x 6	Hünersdorff

## Thread Types

### NPT

#### NPT (National Pipe Thread) Conical, American Tubular Thread

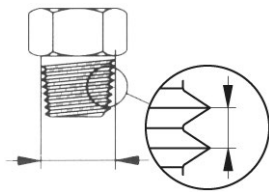
Very easily recognizable due to the conical outer and/or inner diameters, which are self-sealing. NPT is therefore also described as the "sealed thread" or as having a "sealed connection within the thread".



#### Good to know!

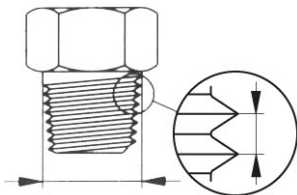
Drawings are of **scale 1:1**

NPT 1/8" – Outer-Ø = 9.9 mm



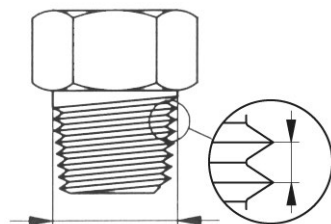
Gradient 27 on 1" = 0.94 mm

NPT 1/4" – Outer-Ø = 13.2 mm



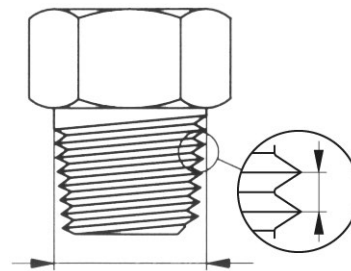
Gradient 18 on 1" = 1.41 mm

NPT 3/8" – Outer-Ø = 16.6 mm



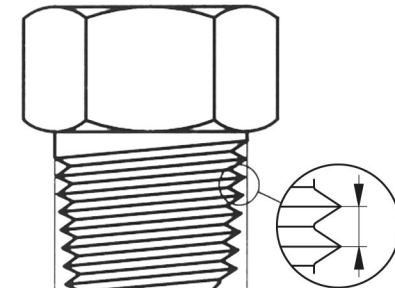
Gradient 18 on 1" = 1.41 mm

NPT 1/2" – Outer-Ø = 20.6 mm



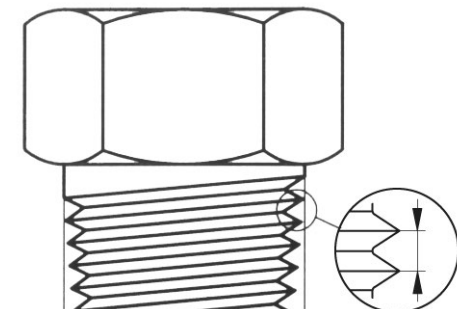
Gradient 14 on 1" = 1.81 mm

NPT 3/4" – Outer-Ø = 26 mm



Gradient 14 on 1" = 1.81 mm

NPT 1" – Outer-Ø = 32.5 mm



Gradient 11.5 on 1" = 2.21 mm



#### SCAT products with NPT 1/8" thread

NPT 1/8" - "tube connector" on Safety Waste Caps. Flexible like no other, with countless tube connections, dividers, collectors etc.





## Thread Types

### G; R; BSP

#### G or R (Whitworth Tubular Thread) and BSP (British Standard Pipe)

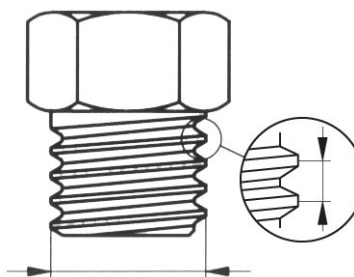
Cylindrical tubular threads are mainly used in english-speaking countries. The measurements, e.g. R 3/4", do not allow for recognition of diameters, the corresponding dimension must be obtained from tables.



#### Good to know!

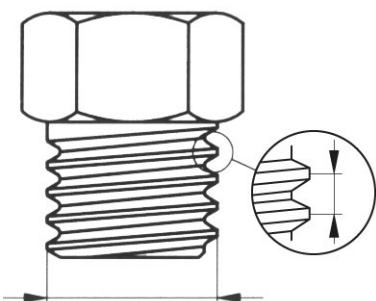
Drawings are of **scale 1:1**

G 1/2" – Outer-Ø = 20.8 mm



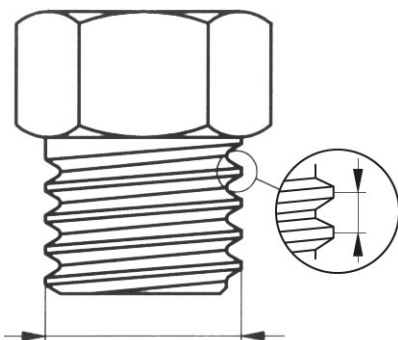
Gradient 14 on 1" = 1.81 mm

G 5/8" – Outer-Ø = 22.8 mm



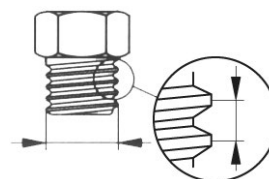
Gradient 14 on 1" = 1.81 mm

G 3/4" – Outer-Ø = 26.3 mm



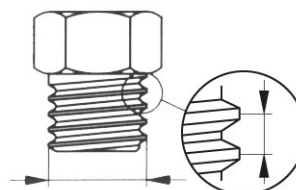
Gradient 14 on 1" = 1.81 mm

G 1/8" – Outer-Ø = 9.6 mm



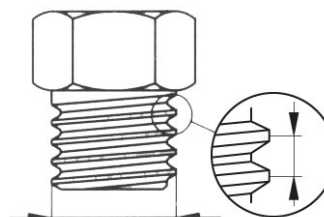
Gradient 28 on 1" = 0.91 mm

G 1/4" – Outer-Ø = 13 mm



Gradient 19 on 1" = 1.34 mm

G 3/8" – Outer-Ø = 16.5 mm

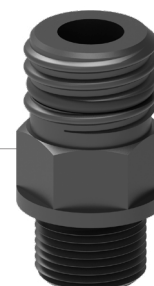


Gradient 19 on 1" = 1.34 mm



#### SCAT products with G thread

e.g. thread adapters



## Thread Types

### M

#### M (Metric ISO-Thread) - standard in the european region

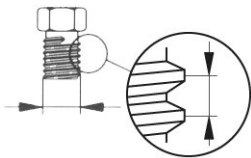
Cylindrical outer and inner diameters, accurate to the very millimetre. Forces are particularly well absorbed, due to the extremely small gradient of the metric thread. The designations begin with an "M", followed by the nominal diameter, e.g. M 10. If there is a gradient that differs from that of the norm, this is given in an addendum, e.g. M 10 x 0.75.



#### Good to know!

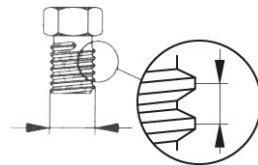
Drawings are of **scale 1:1**

M5 – Outer-Ø = 5 mm



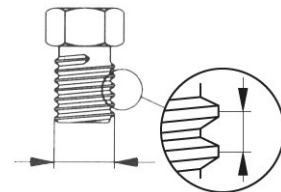
Gradient 0.80 mm

M6 – Outer-Ø = 6 mm



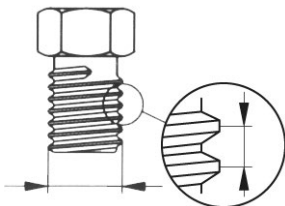
Gradient 1.00 mm

M8 – Outer-Ø = 8 mm



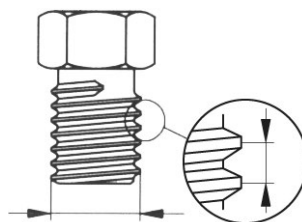
Gradient 1.25 mm

M10 – Outer-Ø = 10 mm



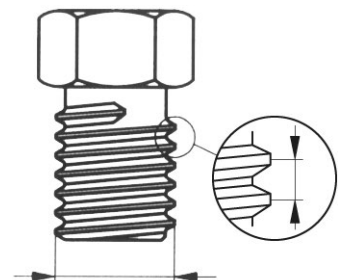
Gradient 1.50 mm

M12 – Outer-Ø = 12 mm



Gradient 1.75 mm

M16 – Outer-Ø = 16 mm



Gradient 2.00 mm



#### SCAT products with M thread

e.g. SymLine pipe connectors



## Thread Types

### UNF 1/4"-28G

#### UNF 1/4"-28G

From the USA. Mainly employed in chromatography/HPLC. Standard sizes are UNF 1/4"-28G and UNF 10-32G. The numbers 28G and 32G refer to the number of thread "steps" taken, over a vertical distance of one inch (25.4 mm).



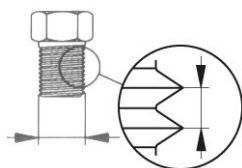
#### Good to know!

Drawings are of **scale 1:1**

#### UNF 1/4"-28G kontra M6

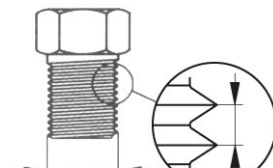
Our HPLC fittings are exclusively constructed with the most typically-used UNF 1/4"-28G HPLC-thread. There also exist fittings and dividers with the very similar thread M6. The two can only be differentiated by exact measurement of the outer diameter, or by using a special test ring or test cap. (It is e.g. therefore possible, to screw the one hollow screw type into the converse piece of the other thread type, at least for 2-3 revolutions). The UNF 1/4" thread has an outer diameter of 6.35 mm, the thread M6 has one of exactly 6.0 mm (production-related tolerances may apply). We recommend the exclusive use of the UNF thread 1/4"-28G, in order to avoid confusion, mistakes being made, or unnecessary double stocking.

UNF 1/4"-28G – Outer-Ø = 6.2 mm



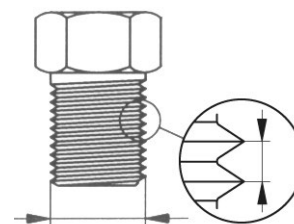
Gradient 28 on 1" = 0.91 mm

UNF 3/8"-28G – Outer-Ø = 9.4 mm



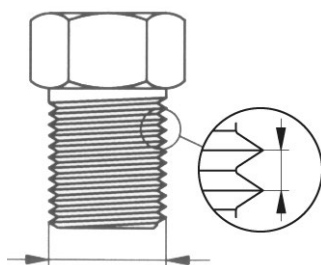
Gradient 24 on 1" = 1.06 mm

UNF 1/2"-28G – Outer-Ø = 12.6 mm



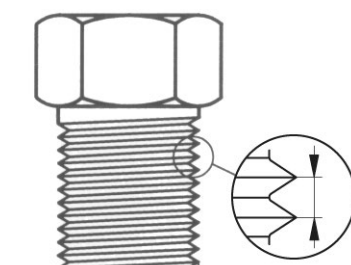
Gradient 20 on 1" = 1.27 mm

UNF 5/8"-18G – Outer-Ø = 15.7 mm



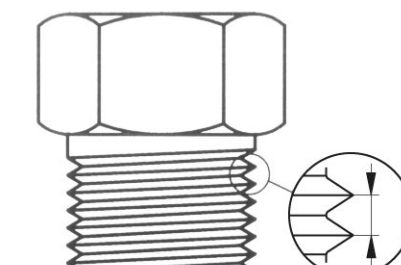
Gradient 18 on 1" = 1.41 mm

UNF 3/4"-16G – Outer-Ø = 18.9 mm



Gradient 16 on 1" = 1.59 mm

UNF 1"-12G – Outer-Ø = 25.2 mm



Gradient 12 on 1" = 2.12 mm



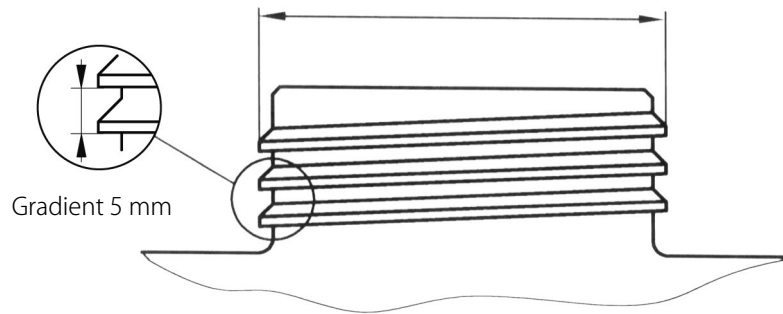
#### SCAT products with UNF 1/4"-28G thread

e.g. fittings, dividers, blind plugs and air valves

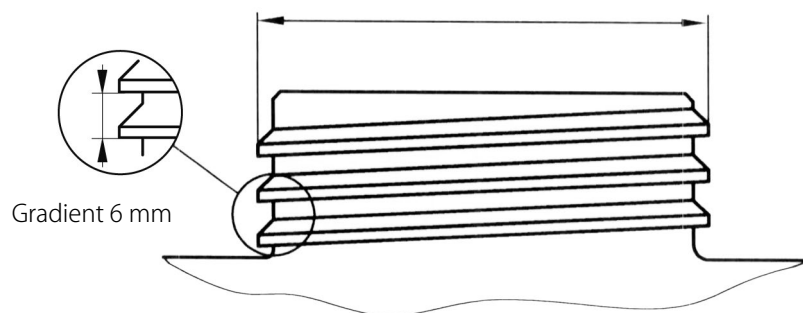


## Thread Types Canisters

S 55 – Outer-Ø = 53.5 mm



S 60 – Outer-Ø = 59.5 mm

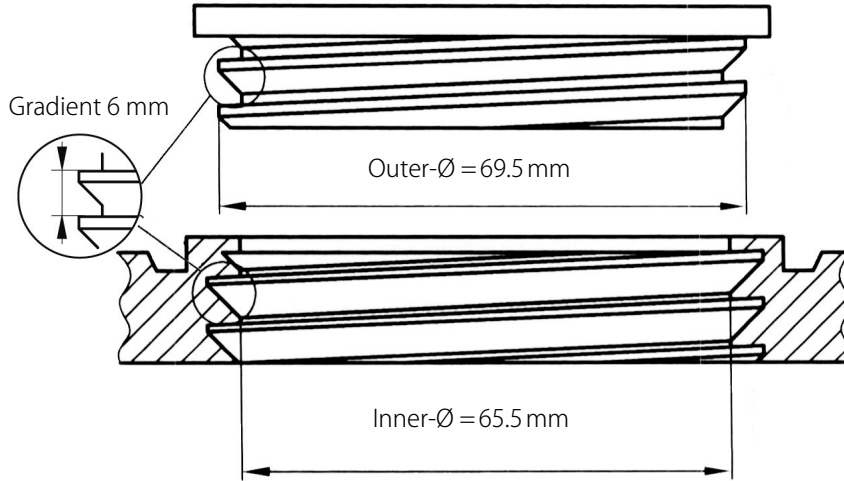


### SCAT products with S thread

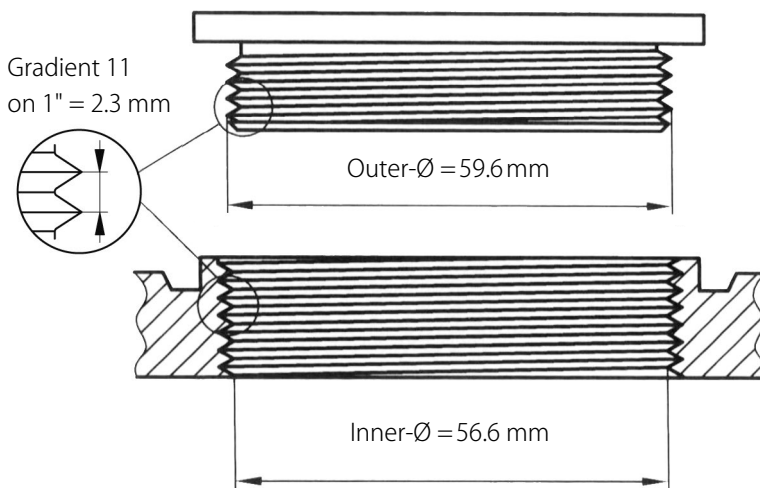
e.g. Safety Waste Caps

# Thread Types Barrels

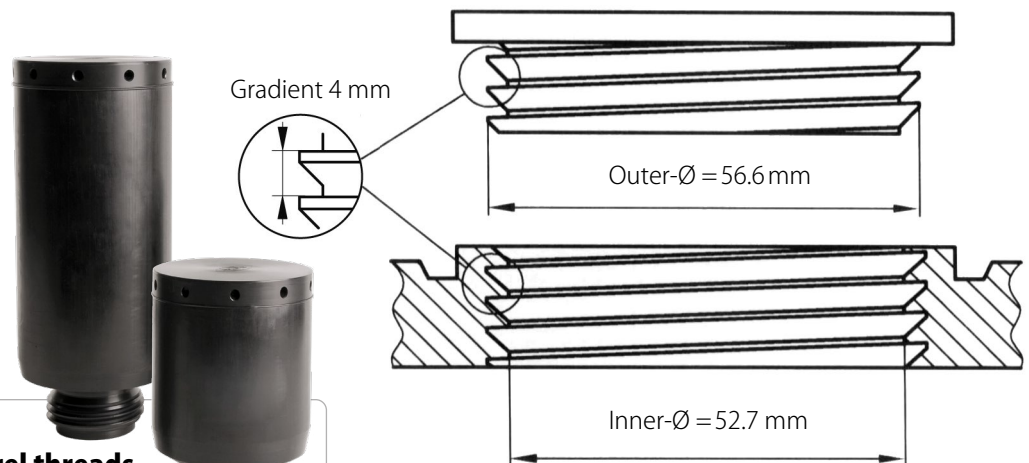
BCS 70x6 e.g. MAUSER 2"®



G2"/ R 2"/ BSP 2"



BCS 56x4 e.g. Tri Sure2"®



### SCAT products with barrel threads

e.g. exhaust filters for barrels





## Thread Types

### Glass Threads

#### GL threads

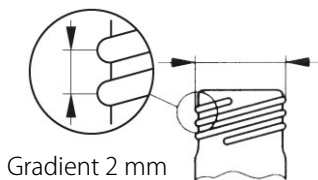
Glass threads are round threads, i.e. the surface of the thread lines is always rounded. The simple form and the rounded surface allow them to be easily constructed on glass bottle necks. The relatively large gradient and the wide edges give it great carrying capacity.



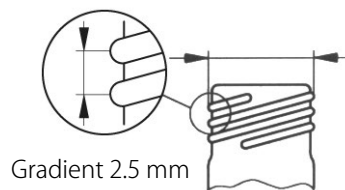
#### Good to know!

Drawings are of **scale 1:1**

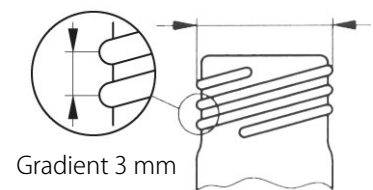
GL 12 – Outer-Ø = 12 mm



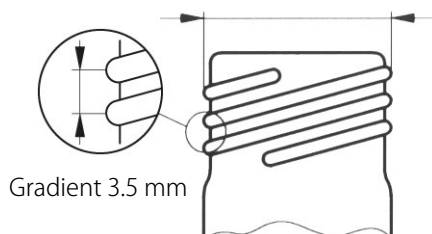
GL 14 – Outer-Ø = 14 mm



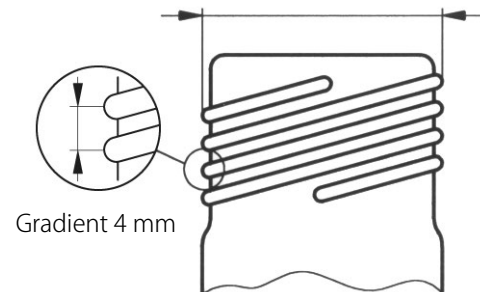
GL 18 – Outer-Ø = 18 mm



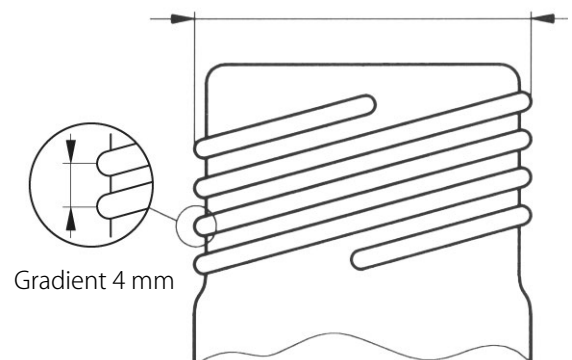
GL 25 – Outer-Ø = 25 mm



GL 32 – Outer-Ø = 32 mm



GL 45 – Outer-Ø = 45 mm



#### SCAT products with GL threads

GL14 - "The Exhaust Filter Connection", e.g. for exhaust filters and blind plugs

GL 28, GL 38, GL 40, GL 45,  
SCAT Safety Cap and  
Safety Waste Cap threads



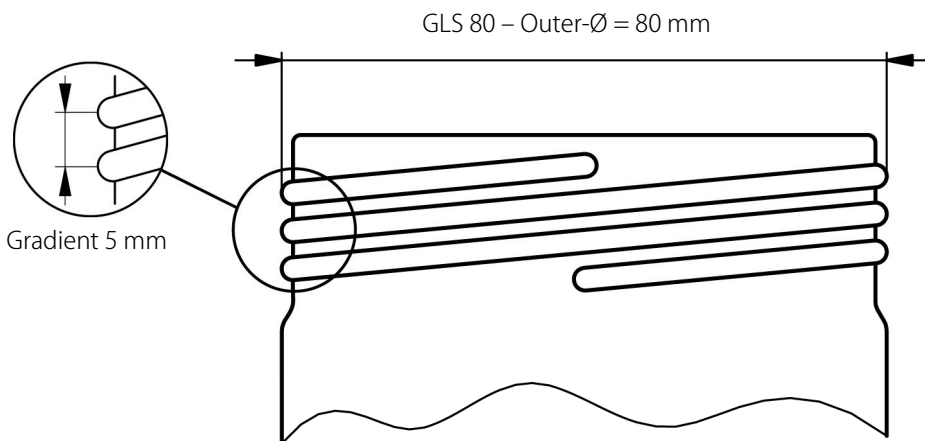
# Thread Types

## Glass Threads



**Good to know!**

Drawings are of **scale 1:1**



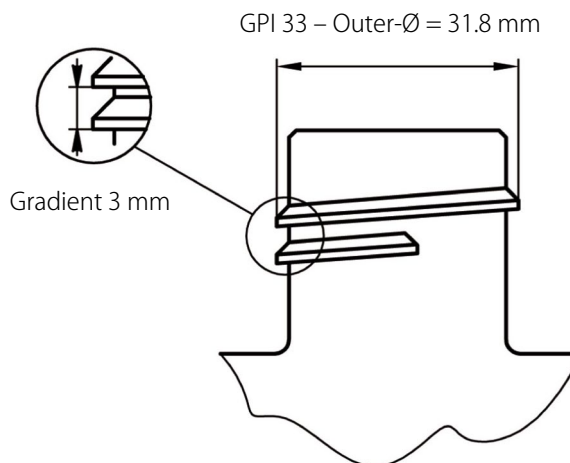
**SCAT products with GLS 80**

e.g. GLS 80 Safety Caps, Safety Waste Caps and bottle rinsing caps



### GPI thread

The abbreviation GPI stands for Glass Packaging Institute, in which the North American manufacturers of glass bottles of every type are represented. The GPI norms are voluntary standards, which serve as the basis for compatibility and exchange regarding glass receptacles and their caps.



## Resistance to Chemicals

### Resistance Table

#### Resistance to chemicals

Due to the wide variety and the different compositions of solvents and substances available on the market, we can assume no guarantee for chemical compatibility.

**As per the most up-to-date information available, materials with best resistance have been selected for SCAT products, in particular with a view to satisfying the requirements of working with aggressive fluids.**

You may obtain information regarding compatibility with specific substances from the manufacturer of your chemicals or other expert sources.

We would be pleased to offer you consultation during selection of suitable products for your application. The responsibility for the selection of the chemicals used lies with the end user.

SCAT Europe offers no guarantee for the results and assumes no obligation or liability concerning the use of these products as regards their chemical compatibility or their abrasive effects.

Resistance to other available chemicals upon request.

Substances (+20°)	Conc.	PTFE	PEHD	PP	PFA	V4A
Acetaldehyde	100,00 %	A	B	C	A	A
Acetamide	100,00 %	A	A	A	A	A
Acetic acid	100,00 %	A	C	B	A	A
Acetic acid	90,00 %	A	A	A	-	A
Acetic acid allyl ester	100,00 %	A	A	C	A	A
Acetic acid butyl ester	100,00 %	A	B	C	A	A
Acetic acid-2-pentyl	100,00 %	A	B	C	A	A
Acetic anhydride	100,00 %	A	C	B	A	A
Acetone	100,00 %	A	A	A	A	A
Acetonitrile	100,00 %	A	A	A	A	A
Acetophenone	100,00 %	A	C	B	A	A
Acetyl chloride	100,00 %	A	C	B	A	B
Acetyl chloride	100,00 %	A	C	C	-	A/C
Acrylonitrile	100,00 %	A	A	A	A	A
Adipic acid	100,00 %	A	A	A	A	B
Allyl acetate	100,00 %	A	A	B	-	A

#### Meaning of the evaluations

Resistance	Meaning
<b>A</b>	Very good resistance after 30 days' exposure, none or only mild damage.
<b>B</b>	Conditional resistance: damage may occur after longer periods of exposure (e.g. hair cracks, mechanical stability affected, discolouration etc.)
<b>C</b>	Poor resistance: can lead to destruction, severe damage, deformation of plastic etc.
<b>A/C</b>	There is a risk of pitting corrosion or stress cracking.
<b>-</b>	Currently no information about chemical resistance available.

Substances (+20°)	Conc.	PTFE	PEHD	PP	PFA	V4A
Allyl chloride	100,00 %	A	B	C	A	B
Aminoacetic acid	10,00 %	A	A	A	-	B
Aminobenzene	100,00 %	A	A	A	A	A
Aminomethane	100,00 %	A	A	A	A	A
Ammonium hydroxide	25,00 %	A	A	A	A	A
Amyl acetate	100,00 %	A	A	B	A	A
Amyl alcohol	100,00 %	A	A	A	A	A
Aniline	100,00 %	A	A	A	A	A
Anisole	100,00 %	A	B	B	A	A
Aqua regia	100,00 %	A	C	C	-	C
Aviation fuel	100,00 %	A	C	B	A	A
Benzaldehyde	100,00 %	A	B	A	A	A
Benzene	100,00 %	A	B	B	A	A
Benzenesulfonic acid	100,00 %	A	A	A	A	A
Benzoic acid	100,00 %	A	A	A	A	A
Benzoyl chloride	100,00 %	A	C	C	A	B
Benzyl alcohol	100,00 %	A	A	A	-	A
Benzyl chloride	100,00 %	A	C	C	A	B
Boric acid	100,00 %	A	A	A	A	A
Buta-1,3-diene	100,00 %	A	C	C	A	A
Butan-2-one	100,00 %	A	C	C	A	A
Butanedioic acid	100,00 %	A	A	A	-	A
Butanol	100,00 %	A	A	A	A	A
Butenedioic acid	100,00 %	A	A	A	A	A
Buthylphenol, tert.	100,00 %	A	B	B	A	A

## Resistance to Chemicals

### Resistance Table

Substances (+20°)	Conc.	PTFE	PEHD	PP	PFA	V4A
Butyl acetate	100,00 %	A	C(B)	C	A	A
Butyl alcohol	100,00 %	A	A	A	A	A
Butyl ether	100,00 %	A	C	C	A	A
Butyric acid	100,00 %	A	C	A	A	A
Camphor	100,00 %	A	C	B	A	A
Carbolic acid	100,00 %	A	A	A	A	A
Carbon disulfide	100,00 %	A	C	C	A	A
Carbon tetrachloride	100,00 %	A	C	C	A	B
Caustic soda	85,00 %	A	A	A	A	A/B
Chloral hydrate	100,00 %	A	B	C	-	-
Chlorine	100,00 %	A	C	C	A	C
Chloroacetic acid	100,00 %	A	A	A	A	C
Chlorobenzene	100,00 %	A	C	C	A	A
Chloroethane	100,00 %	A	B	C	A	B
Chloroethanol-2	100,00 %	A	A	A	A	B
Chloroform (trichloromethane)	100,00 %	A	C	C	A	A
Chlorosulfuric acid	100,00 %	A	C	C	A	C
Chlorotoluene	100,00 %	A	C	B	A	A
Chromic acid	50,00 %	A	C	B	A	B
Chromic acid	<50,00%	A	B	B	A	B
Chromic sulfuric acid	100,00 %	A	C	C	A	B
Citric acid	10,00 %	A	A	A	A	A
Cumene	100,00 %	A	B	C	A	A
Cyclohexane	100,00 %	A	A	A	A	A
Cyclohexanol	100,00 %	A	A	A	A	A
Cyclohexanone	100,00 %	A	B	B	A	A
Decalin	100,00 %	A	B	C	A	A
Decane	100,00 %	A	C	B	A	A
Diacetone alcohol	100,00 %	A	A	A	A	A
Diaminoethane	100,00 %	A	A	A	A	A
Dibutyl ether	100,00 %	A	C	C	A	A
Dichloroacetic acid (also monochloro-)	100,00 %	A	A	A	A	-
Dichlorobenzene	100,00 %	A	B	C	A	-
Dichloroethanes	100,00 %	A	B	C	-	B
Dichloromethane (methylene chloride)	100,00 %	A	C	C	A	B
Diesel fuel	100,00 %	A	B	B	A	A

Substances (+20°)	Conc.	PTFE	PEHD	PP	PFA	V4A
Diethyl ether	100,00 %	A	C	C	A	A
Diethyl ketone	100,00 %	A	B	B	A	A
Diethylamine	100,00 %	A	C	A	A	A
Diethylene glycol	100,00 %	A	A	A	-	A
Diethylene oxide	100,00 %	A	A	C	A	-
Dihydroxybenzene-1,3	50,00 %	A	C	B	A	-
Diisobutylketone	100,00 %	A	B	B	A	A
Dimethylformamide	100,00 %	A	A	A	A	A
Dimethyl ether	100,00 %	A	C	C	A	A
Dimethyl sulfoxide (DMSO)	100,00 %	A	A	A	-	A
Dimethylamine	100,00 %	A	B	B	A	A
Dimethylbenzenes	100,00 %	A	C	C	A	A
Dioxane	100,00 %	A	A	B	A	A
Diphenyl ether	100,00 %	A	C	C	A	A
Dipropylene glycol	100,00 %	A	A	A	-	A
Disodium tetraborate	100,00 %	A	A	A	-	-
Ethanol (ethyl alcohol)	96,00 %	A	A	A	A	A
Ethereal oils	100,00 %	A	C	C	-	A
Ethyl acetate	100,00 %	A	B/C	B/C	A	A
Ethyl acrylate	100,00 %	A	C	C	A	A
Ethyl chloride	100,00 %	A	C	C	A	A/C
Ethylbenzene	100,00 %	A	B	C	A	A
Ethylene glycol	100,00 %	A	A	A	A	A
Ethylene oxide	100,00 %	A	B	B	A	A
Ethylene chlorhydrin	100,00 %	A	A	A	A	A/C
Ethylenediamine	100,00 %	A	A	A	A	A
Ethylmethylketone	100,00 %	A	C	C	A	A
Formaldehyde, Formalin	40,00 %	A	A	A	A	A
Formamide (Methanamide)	100,00 %	A	A	A	A	A
Formic acid	100,00 %	A	A	B	A	B
Fuel oils	100,00 %	A	B	B	A	A
Furfural	100,00 %	A	B	C	A	A
Gasoline, aromatic	100,00 %	A	B	B	A	B
Glycerine	100,00 %	A	A	A	-	A
Glycine	10,00 %	A	A	A	-	A
Glycol	100,00 %	A	A	A	A	A
Glycolic acid	100,00 %	A	A	A	A	A/B

## Resistance to Chemicals

### Resistance Table

Substances (+20°)	Conc.	PTFE	PEHD	PP	PFA	V4A
Heptane	100,00 %	A	B	B	A	A
Hexadecanol	100,00 %	A	A	A	A	A
Hexafluorosilicic acid	100,00 %	A	A	A	A	A
Hexan-1,2,6-triol	100,00 %	A	A	A	A	A
Hexane	100,00 %	A	B	B	A	A
Hexanedioic acid (Adipic acid)	100,00 %	A	A	A	A	A
Hexanol	100,00 %	A	A	A	A	A
Hydrazine hydrate	64,00 %	A	A	A	A	A/B
Hydrochloric acid	37,00 %	A	A	A	A	C
Hydrofluoric acid	45,00 %	A	A	A	A	C
Hydrogen peroxide	90,00 %	A	B	B	A	A
Hydrogen sulfide	100,00 %	A	A	A	A	A
Hydroxyacetic acid (Glycolic acid)	100,00 %	A	A	A	A	B
Isobutanol	100,00 %	A	A	A	A	A
Isooctane	100,00 %	A	B	B	A	A
Isopropanol	100,00 %	A	A	A	A	A
Isopropenyl acetate	100,00 %	A	A	A	A	-
Isopropyl acetate	100,00 %	A	A	B	-	A
Isopropyl ether	100,00 %	A	C	C	A	A
Isopropylbenzene	100,00 %	A	C	C	A	-
Kerosene	100,00 %	A	A	A	A	A
Lactic acid	90,00 %	A	A	A	A	A/B
Menthol	100,00 %	A	A	A	-	A
Methanol	100,00 %	A	A	A	A	A
Methoxybenzene	100,00 %	A	C	C	A	A
Methoxyethanol	100,00 %	A	A	C	A	A
Methyl acetate	100,00 %	A	A	A	A	A
Methyl bromide	100,00 %	A	C	C	A	A/C
Methyl ethyl ketone	100,00 %	A	B	B	A	A
Methyl isobutyl ketone	100,00 %	A	C	C	A	A
Methyl methacrylate	100,00 %	A	A	A	A	A
Methyl phenyl ether	100,00 %	A	C	C	A	A
Methylamine	100,00 %	A	A	A	A	A
Methylbenzene	100,00 %	A	C	C	A	A

Substances (+20°)	Conc.	PTFE	PEHD	PP	PFA	V4A
Methylcyanide	100,00 %	A	A	A	A	A
Methylene chloride	100,00 %	A	C	C	A	A/C
Methyloxirane	100,00 %	A	A	A	A	A
Methylpentanone	100,00 %	A	C	C	A	A
Methylphenylketone	100,00 %	A	C	C	A	A
Mineral oil	100,00 %	A	A	B	-	A
Nitric acid	65,00 %	A	B	C	A	B
Nitrobenzene	100,00 %	A	C	B	A	A
Octane	100,00 %	A	B	B	A	A
Oleic acid	100,00 %	A	C(B)	C(B)	A	A
Oleum	100,00 %	A	C	C	A	A
Oxalic acid	100,00 %	A	A	A	A	A/B
Pentan-1-ol	100,00 %	A	A	A	A	-
Pentan-3-on	100,00 %	A	A	A	A	A
Pentylacetate	100,00 %	A	A	C	A	A
Perchlorethylene	100,00 %	A	C	C	A	-
Perchloric acid	100,00 %	A	B	C	A	-
Petroleum	100,00 %	A	B	B	A	A
Phenol	100,00 %	A	A	A	A	A
Phenylamine	100,00 %	A	A	A	A	A
Phosphoric acid	85,00 %	A	B	A	A	A/B
Phosphorus trichloride	100,00 %	A	B	B	A	-
Potassium hydroxide	100,00 %	A	A	A	A	A
Potassium hypochlorite	20,00 %	A	B	B	A	B
Potassium perchlorate	25,00 %	A	A	A	A	A
Propan-2-ol	100,00 %	A	A	A	A	A
Propane-1,2-diol	100,00 %	A	A	A	A	A
Propionic acid	100,00 %	A	A	A	A	A
Propylene oxide	100,00 %	A	A	A	A	A
Pyridine	100,00 %	A	B	B	A	A
Resorcinol	50,00 %	A	B	A	A	-
Salicylic acid	100,00 %	A	A	A	A	A
Silicone oils	100,00 %	A	A	A	-	A
Silver acetate	100,00 %	A	A	A	-	-
Sodium hydroxide	85,00 %	A	A	A	A	A/B



## Resistance to Chemicals

### Resistance Table

Substances (+20°)	Conc.	PTFE	PEHD	PP	PFA	V4A
Sodium persulfate	25,00 %	A	A	B	A	A
Sodium persulfate	100,00 %	A	A	A	A	A
Styrene	100,00 %	A	C	C	A	A
Succinic acid	100,00 %	A	A	A	A	A
Sulfuric acid	80,00 %	A	A	A	A	B/C
Sulfuric acid, fuming	100,00 %	A	C	C	A	A
Tartaric acid	100,00 %	A	A	A	A	A
Tetrachlorethylene	100,00 %	A	C	C	A	-
Tetrachloroethane	100,00 %	A	B	C	A	-
Tetrahydrofuran (THF)	100,00 %	A	C	C	A	A
Tetrahydronaphthalene	100,00 %	A	C	C	A	A
Tetralin	100,00 %	A	C	C	A	A
Thionyl chloride	100,00 %	A	C	C	A	-
Toluene	100,00 %	A	C	C	A	A
Trichloroacetic acid	100,00 %	A	B	A	A	B
Trichlorobenzenes	100,00 %	A	C	C	A	-
Trichloroethylene	100,00 %	A	C	C	A	B
Triethanolamine	100,00 %	A	A	A	-	A
Triethylene glycol	100,00 %	A	A	A	A	A
Turpentine	100,00 %	A	B	C	A	A
Urea	100,00 %	A	A	A	A	A
Uric acid	100,00 %	A	A	A	-	A

Substances (+20°)	Conc.	PTFE	PEHD	PP	PFA	V4A
Vinyl acetate	100,00 %	A	A	B	A	A
Vinyl chloride	100,00 %	A	A	C	A	-
Vinyl cyanide	100,00 %	A	A	A	A	A
Vinylbenzene, Styrene	100,00 %	A	C	C	A	A
Vinylidene chloride	100,00 %	A	C	C	A	-
Waterglass	100,00 %	A	A	A	-	A
Xylenes	100,00 %	A	C	C	A	A

## Addendum

# Safety Instructions

### Warranty/Safety of our products

Strict quality control ensures you receive faultless, high-quality products from us. However, if a product is defective, we will, of course, replace it free of charge. Since these are technically sophisticated components, we cannot provide warranty for any articles which have been technically modified or damaged by the user.

### Customised products

The same applies to customised products which have been manufactured according to the specifications made by our customers. It is the responsibility of the user to check whether these products meet their technical requirements. We accept no liability for events or accidents caused by incorrect handling or technical modifications to our products by the user.

### Health & Safety

Pay special attention to hazard pictograms (including H and P statements) on Safety Data Sheets (SDS) in your company and on the packaging of your chemicals. When handling substances labelled as hazardous, always wear personal protective equipment (PPE) as specified.

### Chemical compatibility

Due to the variety and different composition of solvents and substances available on the market, we cannot provide warranty for chemical compatibility. State-of-the-art resistant materials have been used for SCAT products, with special focus on requirements relating to work with aggressive liquids. You can obtain information on compatibility with specific substances from your chemical manufacturers or other specialist sources. We can provide support in selecting the appropriate for your application. However, the end user is responsible for the selection of chemicals used. SCAT does neither provide warranty for results nor does it assume any obligation or liability in connection with the use of such products as far as their chemical compatibility or abrasive effects are regarded.

A wide range of information is available for you to download from the SCAT online site. For example, the continuously updated table: 'Plastics – Chemical Resistance to Chemicals' or safety instructions relating to SCAT products. Visit us at:

**[www.scat-europe.com](http://www.scat-europe.com)**

### Grounding and antistatics

Our products for safe grounding of containers and vessels are suitable for connection to current-free and zero potential installations. Connection to power-driven installations or live components must be executed by qualified electricians only!

Please observe the internal safety instructions of your company.

# Addendum

## GHS Hazard Symbols



GHS 01  
Explosive



GHS 06  
Acute toxicity



GHS 02  
Flammable



GHS 07  
Health hazard/  
Hazardous to the ozone layer



GHS 03  
Oxidising



GHS 08  
Serious health hazard



GHS 04  
Gas under pressure



GHS 09  
Hazardous to the environment



GHS 05  
Corrosive

# Addendum

## Terms & Conditions

### § 1 General

- 1.1 The following provisions apply to all initial, ongoing and future business relationships between us and our clients who are contractors/traders within the meaning of § 14 of the German Civil Code (Bürgerliches Gesetzbuch). Our Terms and Conditions of Supply, Performance and Payment apply exclusively and by placing orders with us our customers declare that they are in agreement with these conditions; this applies equally for future business if these conditions are expressly referred to or if they are not referred to but are sent to the customer in connection with an order that we are acknowledging. If the order is placed at variance with our Terms and Conditions of Supply, Performance and Payment, our Terms and Conditions of Supply, Performance and Payment apply even if we do not object to such alternative conditions. Terms and conditions which are at variance with our standard Terms and Conditions of Supply, Performance and Payment apply only if we have expressly acknowledged such alternative conditions in writing. Amendments of and additions to these Terms and Conditions of Business must be made in writing. The customer can only invoke collateral agreements prior to and at the conclusion of the contract if such agreements are confirmed in writing without delay. These provisions do not apply if our customer is a consumer within the meaning of § 13 of the German Civil Code. The language of our contractual dealings is German.
- 1.2 The customer's General Terms and Conditions of Business are excluded unless we have expressly recognized them.
- 1.3 Our offers are subject to final confirmation; we reserve the right to make technical changes to our products. Files that are important for conducting business may be stored by us on data processing equipment.
- 1.4 Supply contracts and all other agreements (including collateral agreements) as well as statements made by our representatives are only binding in law on us if confirmed in writing. Business correspondence printed on data processing equipment (e.g. order confirmations, invoices, credit notes, extracts from accounts, payment reminders) is binding in law without a signature.
- 1.5 We draw our customers' attention to the fact that we process and transmit their personal data (exclusively for business purposes) with the aid of electronic data processing equipment in accordance with the requirements of the German Federal Data Protection Act (Bundesdatenschutzgesetz).

### § 2 Agreement on prices

- 2.1 Our prices exclude any Value Added Tax which may be imposed by law and are ex works. In case of orders for which no prices are agreed, our prices valid on the day of delivery apply and are expressed in Euros (EUR) unless indicated otherwise.
- 2.2 If changes to the prices should occur up to the day of delivery, we reserve the right to amend our prices accordingly. However, this only applies to delivery periods longer than 4 months and price changes not exceeding 10%. If the price change is greater, a new price agreement must be concluded. If such an agreement should not be concluded, we have the right to withdraw from the contract in writing within 14 days.
- 2.3 Confirmed prices only apply when the quantities confirmed are accepted by the customer.
- 2.4 Packing, transport, freight and insurance costs are charged to the customer.

### § 3 Payment

- 3.1 The purchase price and/or agreed compensation for work including all costs are due for payment without reduction on receipt of invoice. Our invoices must be paid within 14 days without deductions. Payments are not deemed to have been received until the day on which we have access to the funds.
- 3.2 Payments must be made including VAT and without deduction of any prompt payment discounts or other deductions unless any other terms of payment are expressly agreed in writing.
- 3.3 Bills of payment are only accepted by express agreement and – also in the case of checks – only as an undertaking to pay and subject to our acceptance of them on a case by case basis. Discounting and other fees must be born by the customer and are due for payment immediately.
- 3.4 All payments are credited first to interest and costs and thereafter to our oldest receivables, irrespective of the customer's directions.
- 3.5 If payments are late, we will invoice interests on such payments at the level allowed by law. The assertion of additional claims for compensation is not allowed.
- 3.6 If payment should be late, checks and bills of exchange dishonored, payments suspended, the filing of proceedings for the arrangement of debt, failure to abide by the terms of payment or if circumstances arise likely to reduce the customer's creditworthiness, all our receivables – including in the event if a payment moratorium – are due for immediate payment. We are also entitled to perform services and make deliveries which are still outstanding only against the payment of cash or to withdraw from the contract after setting a reasonable grace period and to require compensation in lieu of performance.
- 3.7 Claims arising from the contractual arrangement may only be assigned by the customer with our express consent. Off-setting or retention are only permitted in respect of uncontested counterclaims which have been judged to be final and absolute. We are entitled to refuse the exercise of the right of retention in the form of a provision of a bond or a surety (Bürgschaft).

### § 4 Retention of title

- 4.1 All our deliveries are made with retention of title (goods subject to retention of title). Title does not pass to the customer until he has paid all his liabilities owed to us (including those arising from incidental claims) arising from our supplies and services. If we are trading with the customer on open account, the goods subject to retention of title are deemed to be collateral for our account balance including when payment is made against liabilities which have been specifically excluded.
- 4.2 If goods we have supplied should be mixed with or connected to other objects, the customer will assign to us (joint) title on the item arising therefrom in the ratio of the value of our goods subject to retention of title to the invoice value of the other goods used. If the customer should prejudice our rights set out above, he is obliged to pay us compensation. Dismantling and other costs are for the customer's account.
- 4.3 The customer may only sell the goods we delivered in the normal course of business and in such a case may only sell or use them (e.g. as part of a contract for work and services or a contract for work done and materials supplied) if his customer has not excluded the reassignment of the receivable arising from the resale or re-use of the goods. The customer is obliged to ensure that his customer delivers any retention of the right to consent to the assignment to us in the required form. The customer is not allowed to pledge by way of security or hypothecate the goods to which title is reserved.
- 4.4 The customer must inform us immediately of any attachment, even if such attachment is imminent or any other prejudice to the right of ownership in writing and to third parties and to us. In the case of attachments, a copy of the return of execution must be sent to us.
- 4.5 If a customer should default on payment, we are entitled to demand return of the goods subject to right of retention of title and to procure direct possession of such goods for us or via authorized persons, irrespective of where the goods are located. The customer is obliged to return to us the goods to which title is reserved and is also obliged to provide us with the information necessary for us to assert our rights and to surrender documents for this purpose. The request for the goods is not deemed to be withdrawal from the contract. The same applies for the withdrawal of goods subject to retention.
- 4.6 In order to act as collateral for our claims (including future claims) arising from the business relationship, the customer hereby assigns to us all the receivables (including those on open account) with all ancillary rights which arise to him through the resale and other use of the goods subject to retention of title (e.g. combination, processing, installation in a building).
- 4.7 If the sale or other use of our goods subject to retention of title – in whatever state – should be made in conjunction with the sale or other use of objects to which third party rights are attached and/or in conjunction with the performance of services by third parties, the assignment of future claims is limited to the invoiced value of our invoices.
- 4.8 The customer is entitled to collect receivables which have been assigned to us. In the event of payment default, suspension of payments, the application for or opening of insolvency or out of court composition proceedings or other deterioration of the customer's assets, we may revoke this authorization to collect receivables. If so required, the customer must inform us of the receivables which have been assigned and of the parties owing such receivables, and provide us with all information necessary for the collection of these receivables, to surrender to us the associated documents and inform the debtor of the assignment. We are also entitled to inform the customer's debtors of the assignment and require the debtors to pay us.
- 4.9 If the realizable value of the collateral to which we have been entitled in accordance with the above provisions should exceed the value of our receivables by more than 10%, we are obliged to release the excess collateral at our option if so required by the customer.

### § 5 Supplies and service

- 5.1 Partial deliveries are only permitted to a reasonable extent. We may invoice partial payments to a reasonable degree. We reserve the right to correct orders so that they comply with packaging units. The order is deemed to be completed if plus or minus 10% of the quantity is delivered.
- 5.2 The delivery route, delivery method, packaging and other protection for deliveries are at our option. Transport risks are borne by the customer in all cases. We are entitled, but not obliged, to insure deliveries in the name and for the account of the customer.
- 5.3 The customer must arrange for any damage and/or loss to be recorded in writing by the carrier immediately on receipt of the goods and claims asserted.
- 5.4 Shipments that are returned to us will only be accepted insofar as the fact that they are being reported to us in advance, in which case the following conditions must be fulfilled:
  - a) The identification that the customer receives when reporting a return shipment to us must be stated on the return documents and
  - b) All such shipments must be reported in our incoming goods department by means of the freight papers on which this identification number is noted.
- 5.5 The following rules apply to return shipments excepting those for return of defective delivered goods (Sect. 5.4):
  - a) The goods were delivered at most 4 weeks before in case of deliveries within Germany, at most 6 weeks before in the case of deliveries to European customers and at most 8 weeks before in the case of deliveries to overseas customers.
  - b) The regulations of Section 5.4 apply to reporting, labeling and acceptance of return shipments.
  - c) Only return goods that are undamaged, unopened and have no additional writing or labels on them – so that these goods can be resold by us – will be accepted.

# Addendum

## Terms & Conditions

- d) The return delivery takes place at the expense and risk of the customer.
- e) In addition, a processing fee of 20% of the goods' value will be charged to the customer, whereby this charge shall be at least 30.00 Euros per return shipment. All delivery dates are ex works.

### § 6 Passage of risk and placement of performance

- 6.1 We bear the risk up until the time when the goods are handed over to the mail service or to the carrier or the company charged with organizing the transportation.
- 6.2 The customer also bears the risk before hand-over if he delays the hand-over.
- 6.3 The place of performance for delivery and payment is our company seat in Mörfelden.

### § 7 Time limits

- 7.1 If the customer should be in breach of his obligations of cooperation (e.g. by failure to call off the goods in time and refusal to accept them), we are entitled, at the end of a grace period which has elapsed without performance being made, to take the necessary steps ourselves and to deliver the goods or to withdraw from that part of the supply contract where performance has not been made. Our right to require compensation for breach of duty and compensation in lieu of performance is unaffected hereby. In the case of call-off orders, the customer must take the whole quantity within 12 months.
- 7.2 In the case of goods which we supply but do not manufacture ourselves, supply is subject to timely and correct deliveries to ourselves unless we are responsible for late, incorrect or short delivery.
- 7.3 Force majeure events extend the delivery time commensurably and entitle us to withdraw from the contract in whole or in part. Strikes, lockouts, disruptions of operations or other unanticipated circumstances for which we are not responsible and which materially impede delivery or render delivery impossible are of equal ranking with force majeure. This also applies if the above-mentioned circumstances occur during a delivery delay or at a supplier.
- 7.4 If the time period or an agreed date is exceeded, the customer has the right to require us to state within two weeks whether we are withdrawing from the contract or wish to deliver within a reasonable grace period. If we fail to provide a statement, the customer may withdraw from the contract in so far as performance is without interest to him.

### § 8 Liability for defects

- 8.1 The goods supplied are free from material defects if they comply with the product description or, in so far as no product description is available, comply with the relevant state of the art. We reserve the right to make changes in design and/or workmanship which do not prejudice the fitness for use or value of the goods which are to be supplied; such changes do not justify a complaint for defects. If defects do not prejudice the fitness for use or the value of the goods which are supplied or only prejudice such fitness and value to an immaterial extent, there are no grounds for claims due to defects.
- 8.2 Guarantees relating to the character and durability of the goods which are supplied are only deemed to have been accepted to the extent that we have expressly recognized the guarantee in writing as such. Guarantees which our suppliers have made in written guarantees, in relevant publicity or other product documentation, are not made by us. They obligate only the supplier who made this acceptance of guarantee.
- 8.3 Defects must be noted without delay and are excluded if they are not received by us within 2 weeks of the receipt of delivery. Defects which cannot be ascertained within this period even after the most careful examination must be reported to us without delay and not later than 2 weeks after discovery. We are not responsible for damage due to breakage of glass during transportation caused after the transfer of risk. Breakages with a value of up to and including € 20.00 will not be replaced.
- 8.4 If the goods which were delivered should exhibit defects or if they fail to comply with a warranted property, we will, at our option, either rectify the defect free of charge or replace the goods by defect-free goods (subsequent performance). The customer must allow us, or a person authorized by us, the time and opportunity for such actions. If this does not occur or if modifications or repairs are undertaken to the object which is the subject of the complaint, we are released from liability for the defect.
- 8.5 If subsequent performance should fail or if subsequent performance is not made within a reasonable grace period imposed on us by the customer, the customer may require a reduction in price or withdraw from the contract. The purchaser cannot require reimbursement for his expenses incurred to no effect.
- 8.6 Claims by the customer for expenditure necessary for the purpose of subsequent performance (Clause 8.4) or reversal after withdrawal from the contract (Clause 8.5), especially transportation, shipping, labor and material costs are excluded in so far as the expenditure arose because the goods were installed in a location difficult to access. The same applies mutis mutandis if the goods which were delivered were installed in a location outside the Federal Republic of Germany.
- 8.7 Damage which occurs through incorrect or defective installation, commissioning, handling, operation or maintenance or through the use of unsuitable apparatus or apparatus other than the specified apparatus do not give rise to any grounds for claims for defects.
- 8.8 The time limits specified by law for the assertion of claims for defects applies. The time period commences on the day of our delivery. In the event of loss of life, bodily injury or impairment of health and in the event of gross or intentional neglect of duty on our part and in the event of fraudulent concealment of a defect or if properties have been warranted, the normal statutory prescription periods apply.
- 8.9 For the remainder, Clause 9 applies for claims for compensation. Additional claims by customers for defects are excluded.

### § 9 Compensation

- 9.1 We accept liability for compensation and reimbursement of expenditure incurred to no effect (§ 284 of the German Civil Code) for reason of breach of contract or non-contractual obligations (e.g. for reason of default or tortious acts) only in the case of intent or gross negligence; in the case of culpable loss of life, bodily injury, fraudulent concealment of a defect or acceptance of a warranty as to properties or under the German Product Liability Act (Produkthaftungsgesetz) we only accept liability for personal loss or for damage to property in the case of objects used for private purposes.
- 9.2 In addition we accept liability for breach of material contractual obligations also in the event of ordinary negligence. However, in this case our liability is limited to damage which could have been reasonably foreseen at the time of conclusion of the contract and which is typical under the contract.
- 9.3 In the case of loss caused by delay and in the event of ordinary negligence, we only accept liability amounting to 5% of the purchase price agreed with us.
- 9.4 The purchaser has to notify us immediately in writing about potential consequences of delay.
- 9.5 The provision above does not cause any change of the burden of proof in the detriment of the customer.

### § 10 Intellectual property rights, confidentiality

- 10.1 We retain ownership and all intellectual property rights of our designs, samples, drawings, technical documentation, cost estimates even if the customer has accepted the costs thereof. The customer may only use the designs etc. in a manner agreed with us. He may not manufacture the goods without our written consent or cause the goods to be manufactured by a third party.
- 10.2 In so far as we supply goods in accordance with designs specified by the customer, the customer warrants to us that intellectual property rights and other third party rights are not breached by their manufacture and supply. He must compensate us for all losses resulting from such infringements.
- 10.3 The customer must retain confidentiality vis-à-vis third parties in respect of all information not in the public domain which was obtained as a result of this business relationship.
- 10.4 Drawings, pictures, sketches and weights are approximate/conditionally authoritative, save as confirmed expressly and bindingly. The customer guarantees that the documents do not infringe the third party rights of third persons. He has to indemnify us and hold us harmless for any loss damage or costs, including reasonable attorneys' fees, resulting from any third party claim, action or demand.

### § 11 Records

Documents, drawings and pictures supplied by us must not be made available to any third party or reproduced or used for any purpose outside this contract.

### § 12 Provision in respect of

electronic business transactions

If we use a tele or media service within the meaning of § 312e of the German Civil Code for the purpose of the conclusion of a contract for the supply of goods or the performance of services, the customer waives

- provision and demonstration of a system which the customer can use to recognize and correct entry errors before the order is transmitted, and
- provision of information in respect to
  - the languages in which the contract can be concluded,
  - the steps to be carried out for the contract to be concluded and
  - storage of the contract text after conclusion of the contracts so that it is accessible by the customer.

### § 13 Final provisions

- 13.1 The place of jurisdiction and performance is Mörfelden in so far as the customer is a merchant. However, we are also at liberty to take legal action before the court competent for the customer's legal domicile.
- 13.2 If a provision of these General Terms and Conditions of Business or in other agreements between the customer and ourselves should become invalid, the validity of all other provisions or agreements is unaffected thereby. If a provision of these contractual terms and conditions is invalid, after taking into account the other provisions this provision is to be replaced by a valid provision which comes closest to the economic purpose of the invalid provision.
- 13.3 This contract is governed exclusively by the law of the Federal Republic of Germany. International law, including international conventions on the cross-border sale of goods, is excluded.

Status 02/2023. The continuously updated version of Terms and Conditions can be found at: [www.scats-europe.com](http://www.scats-europe.com)





# Technical Support

@ info@scat-europe.com

+49 (0) 61 05 / 30 55 86 - 0

www.scat-europe.com

DE 



EN 



scat-europe-gmbh



SCATEurope



@SCATEurope



scateurope





## SCAT - Europe GmbH

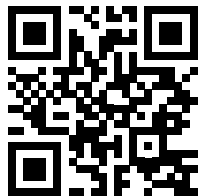
Waldecker Straße 7  
64546 Mörfelden-Walldorf  
Germany

 **+49 (0) 61 05 / 30 55 86 - 0**

 **+49 (0) 61 05 / 30 55 86 - 99**

 **info@scat-europe.com**

 **www.scat-europe.com**



## SCAT Lab Safety

1704 East Blvd., Suite 101  
Charlotte, NC 28203  
USA

 **+1-800-454-1326**

 **info@scatlabsafety.com**

 **www.scatlabsafety.com**

